



INSTRUCTIONS FOR CONTINUED AIRWORTHINESS  
ELECTRICAL POWER SUPPLY FOR OPTIONAL  
50 AMP/LOGLINE/CAROUSEL SYSTEM  
EC 130 T2

AIRBUS HELICOPTERS CANADA LIMITED

**SUBJECT:**

Required maintenance for the Electrical Power Supply for Optional 50 AMP/Longline/Carousel System (P/N 130-900024).

**APPLICABILITY :**

Aircraft with the subject modification embodied in accordance with TCCA STC No. SH15-48 or any relevant foreign approvals.

THE INFORMATION CONTAINED IN THIS DOCUMENT SHALL BE TREATED AS THE PROPERTY OF AIRBUS HELICOPTERS CANADA LIMITED (AHCA). THE RECIPIENT OF THIS DOCUMENT SHALL NOT DISCLOSE ANY INFORMATION CONTAINED HEREIN TO THIRD PARTIES WITHOUT THE WRITTEN PERMISSION OF AHCA, AND SHALL NOT USE OR REPRODUCE THIS DOCUMENT IN WHOLE OR IN PART FOR ANY PURPOSE OTHER THAN ITS ORIGINALLY INTENDED PURPOSE, OR TO EVALUATE ITS CONTENTS.

	NAME AND SIGNATURE	DATE	COMPANY DEPARTMENT
PREPARED BY:	D. Kerr <i>D. Kerr</i>	23 Sept, 2015	AHCA ENGINEERING
PREPARED BY:			
CHECKED BY:	C. Timmins <i>C. Timmins</i>	23 <sup>rd</sup> Sept, 2015	AHCA ENGINEERING
CHECKED BY:	B. Gow <i>D. Boyko</i>	14 Oct, 2015	ADS
REV. 0 ACCEPTED (Civil A/W Authority)	(As per ICA Compliance Check Sheet) <i>C. VOICU</i>	16.10.2015	TCCA
REV. 0 RELEASED BY:	P. Sharpe <i>[Signature]</i>	23 Oct 2015	AHCA ENGINEERING



**INSTRUCTIONS FOR CONTINUED AIRWORTHINESS  
ELECTRICAL POWER SUPPLY FOR OPTIONAL  
50 AMP/LOGLINE/CAROUSEL SYSTEM  
EC 130 T2**

**AIRBUS HELICOPTERS CANADA LIMITED**

**RECORD OF REVISIONS**

Rev.	Pages at this Revision	Description, Reason Changed Pages	Prepared (name and date)	Checked (name and date)	App'd/Acc'd (Civil A/W Authority) (name and date)	Released (name and date)
0	1 through 28	Original Issue	See page 1.	See page 1.	See page 1.	See page 1.

- NOTE: Revisions to this document will be distributed to operators of this equipment by the STC holder.
- NOTE: Revised portions of affected pages are identified by a vertical black line in the margin adjacent to the change.
- NOTE: Minor changes are released in accordance with TCCA-ACCEPTED CAR 521.154 procedures (ref. DAPM-E-001).

### CONTENTS

SECTION	TITLE	PAGE
1	DESCRIPTION .....	4
2	AIRWORTHINESS LIMITATIONS .....	12
3	CONTROL AND OPERATION .....	13
4	INSPECTION SCHEDULE AND MAINTENANCE ACTION .....	14
5	REPLACEMENT COMPONENTS AND REPAIR / OVERHAUL INFORMATION	16
6	TROUBLESHOOTING .....	17
7	SPECIAL TOOLING .....	23
8	REMOVAL AND REPLACEMENT .....	23
9	WEIGHT AND BALANCE DATA .....	25
10	PLACARDS AND MARKINGS .....	26

### FIGURES

FIGURE	TITLE	PAGE
1	General Layout .....	5
2	Pilot's Cyclic Stick Grip .....	6
3	Arming indicator switch for Longline/Carousel and 50 Amp Switches .....	7
4	Longline with 50 Amp Power System Belly Connector .....	8
5	50 Amp/Longline/Carousel Control Box Assembly .....	9
6	Ground Stud installation .....	10
7	50 Amp/Longline/Carousel System, Wiring Diagram .....	19
8	50 Amp/Longline/Carousel System, Wiring Diagram (continued) .....	20
9	50 Amp/Longline/Carousel System, Wiring Diagram (continued) .....	21
10	Typical label location on the Instrument Panel .....	26
11	Labels located on Pilot's Cyclic Stick Grip .....	27
12	Label located on aft lower cowling .....	28

### TABLES

TABLE	TITLE	PAGE
1	Every 150 FH or 12 M (Margin: 15 FH or 36 D) .....	14
2	Every 600 FH or 24 M (Margin: 60 FH or 73 D) .....	15
3	Unscheduled Maintenance .....	16
4	Troubleshooting .....	17

**1. DESCRIPTION**

- A. The Electrical Power Supply for Optional 50 AMP/Longline/Carousel System provides electrical power for optional equipment. Refer to Figure 1 for General Layout.

The electrical connection between the belly mounted connector and the optional equipment is provided by the installer and must include a breakaway type connection when used in conjunction with the cargo hook.

A momentary switch for the longline release or the 50 AMP power relay is located under the lever on the pilot's cyclic grip. A momentary switch located on the pilot's cyclic grip activates power for the Carousel. Refer to Section 1, Figures 2 and 3.

The system arming switches are located on the load meter housing which is located on the LHS door post adjacent to the lower LH corner of the windshield. Refer to Figure 4.

The 50 AMP/Longline/Carousel System is available in the following variants:

Specification	Installation Drawing number	Variant
Cyclic Standard Switches (standard)	130-900024-01	- 01 variant (130-900024-01); - does not include Cyclic Carousel Switch Option
Cyclic Carousel Switch	130-900024-02	- 02 variant (130-900024-02); - Cyclic Standard Switch with Cyclic Carousel Switch option.

The 50 AMP/Longline/Carousel System consists of the following main components:

**Fixed Provisions**

- Switch Housing Assembly
- Connector Bracket

**Detachable Provisions**

- 50 AMP/Longline/ Carousel Control Box Assembly
- Control Box Base
- Bonding Jumper

For instructions of initial installation see IP-AHCA-140.

- B. These Instructions for Continued Airworthiness are applicable to aircraft with the subject modification embodied.

**AIRBUS HELICOPTERS CANADA LIMITED**

1. **DESCRIPTION** (continued)

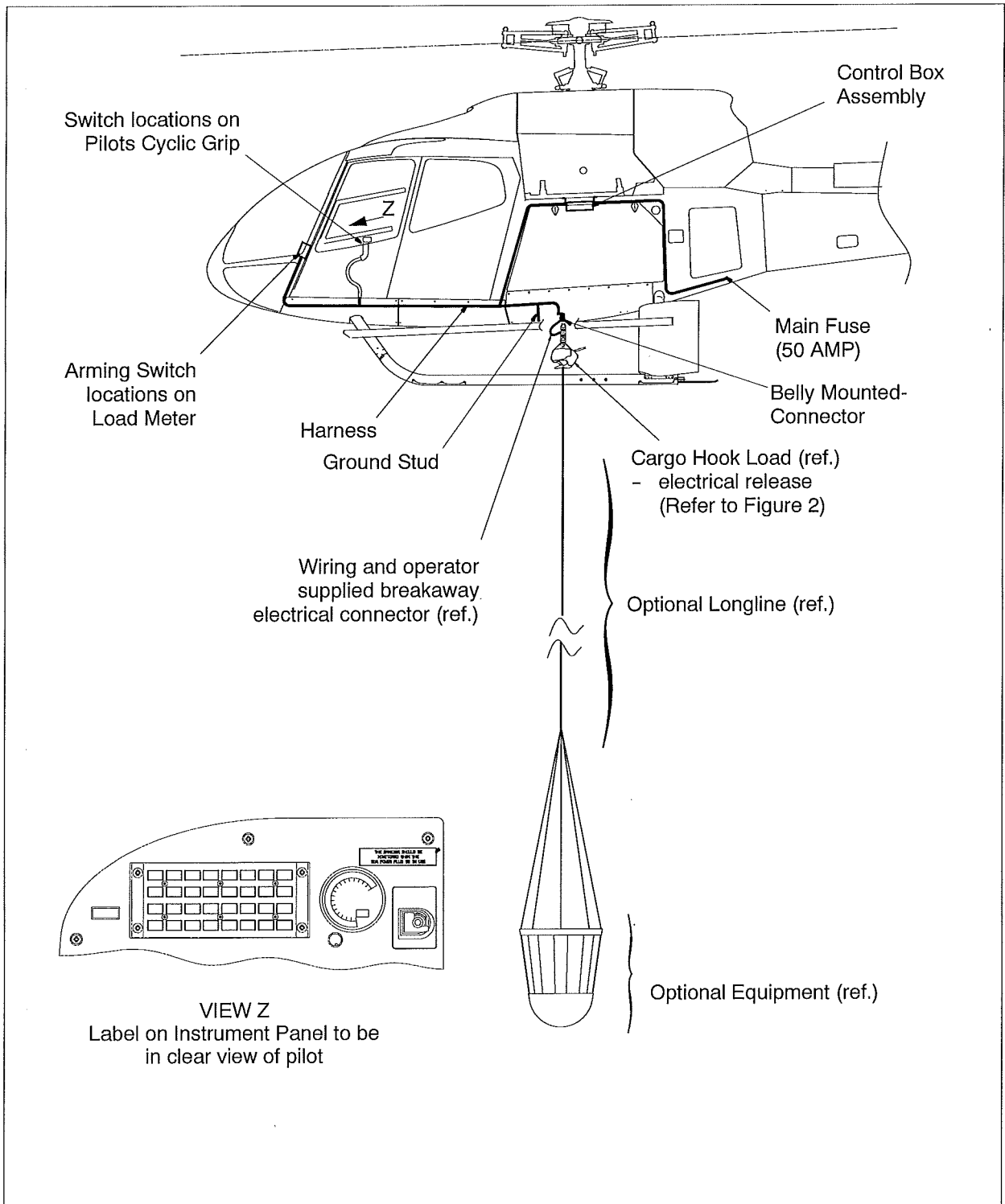

Figure 1 General Layout

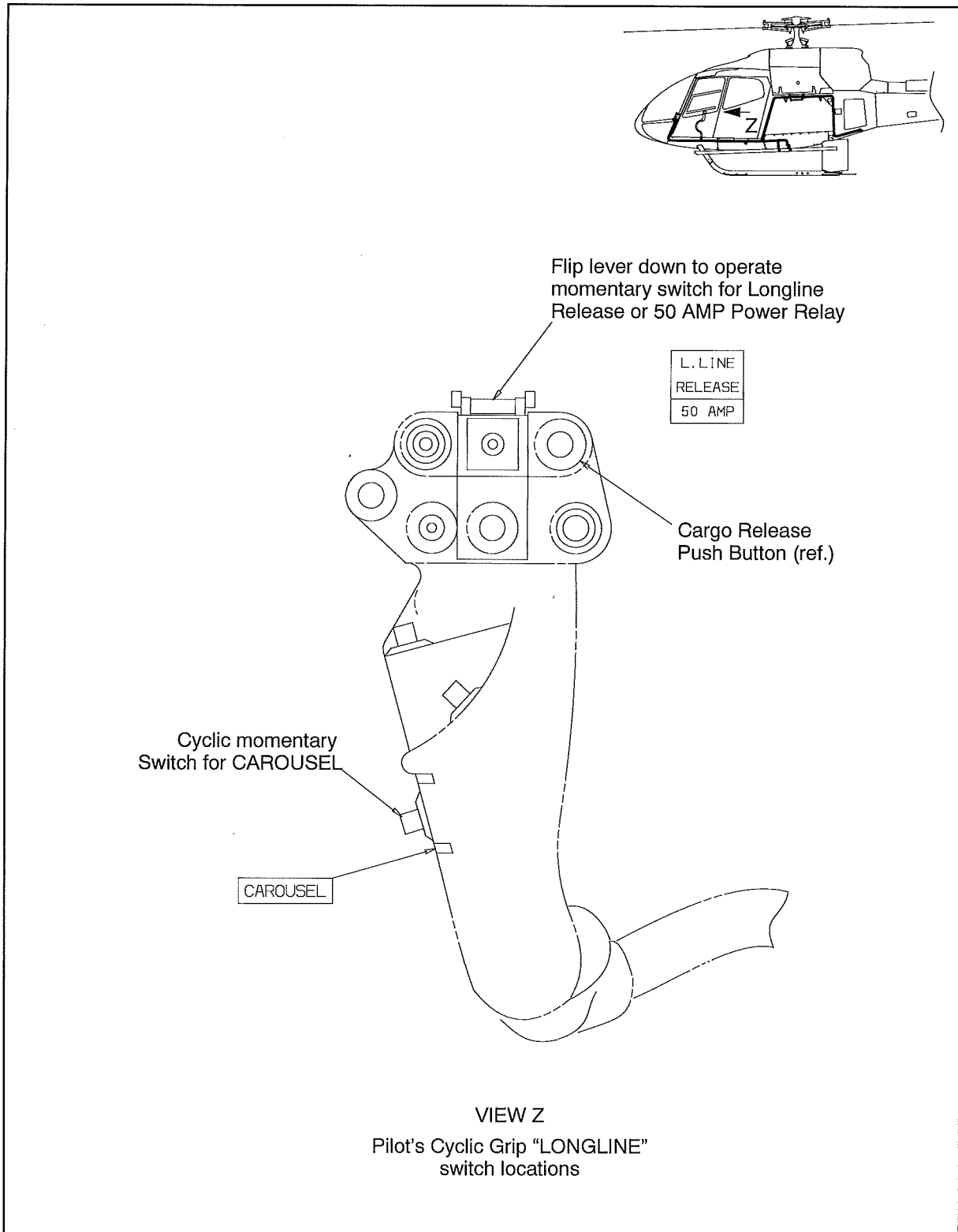
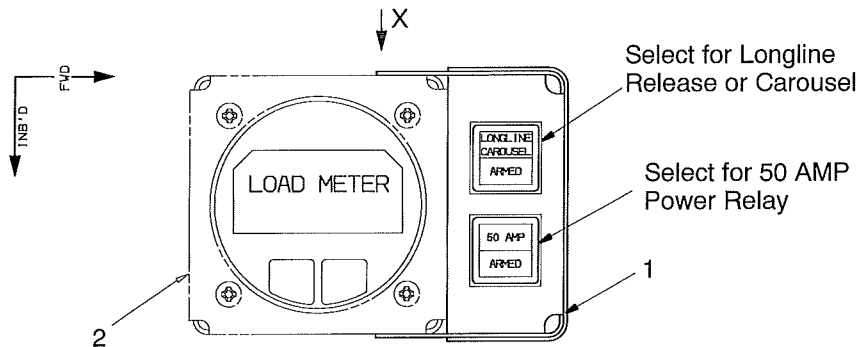
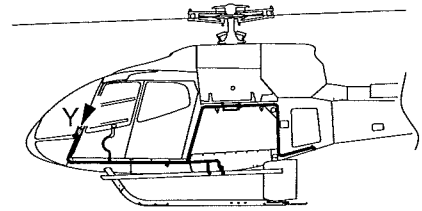

Figure 2 Pilot's Cyclic Stick Grip

AIRBUS HELICOPTERS CANADA LIMITED

Legend (for Figure 3)
Item Description

1. Switch Housing Assembly
2. Loadmeter Housing  
(part of cargo sling installation)

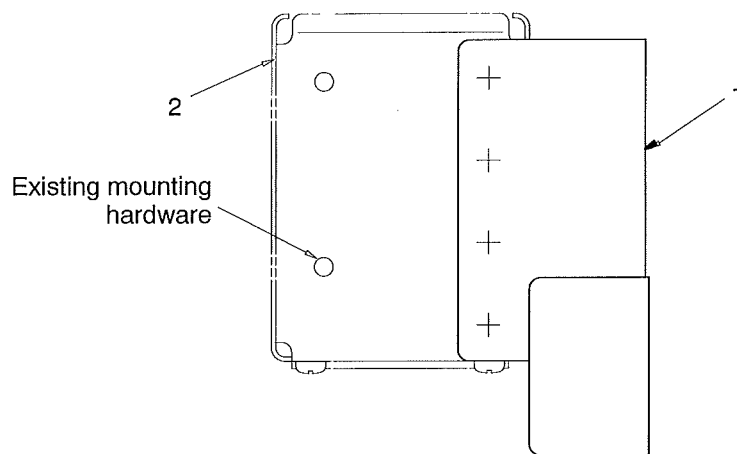

VIEW Y (rotated)

 Switch locations on load meter housing  
 positioned on LHS door post area.

VIEW X

Side view showing mounting hardware

**NOTE:** Arming indicator switches for Longline/Carousel  
 and 50 AMP Switch:

Green Filter upper segment only.

Amber Filter lower segment only.

Figure 3 Arming indicator switch for Longline/Carousel and 50 Amp Switches

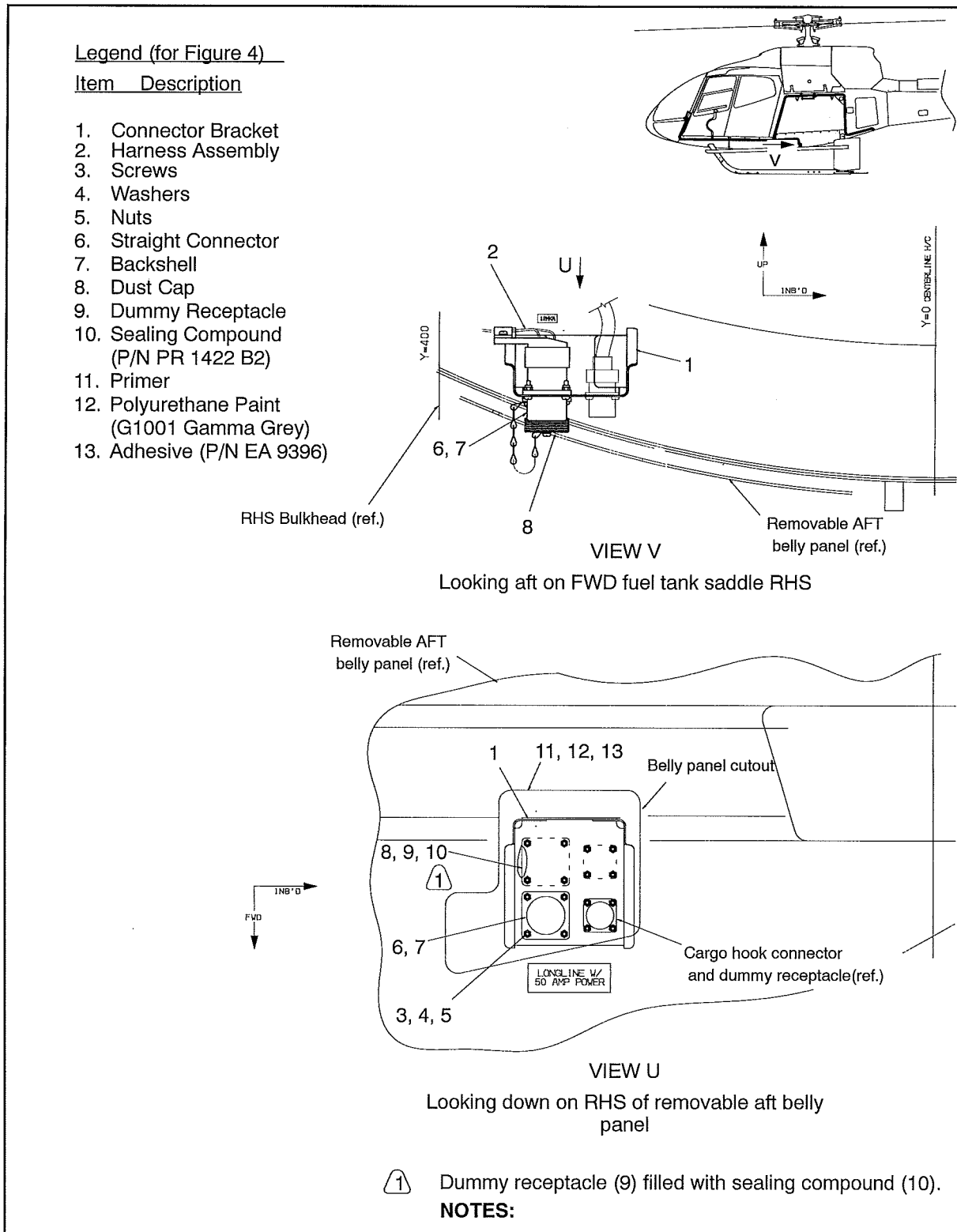

Figure 4 Longline with 50 AMP Power System Belly Connector



AIRBUS HELICOPTERS CANADA LIMITED

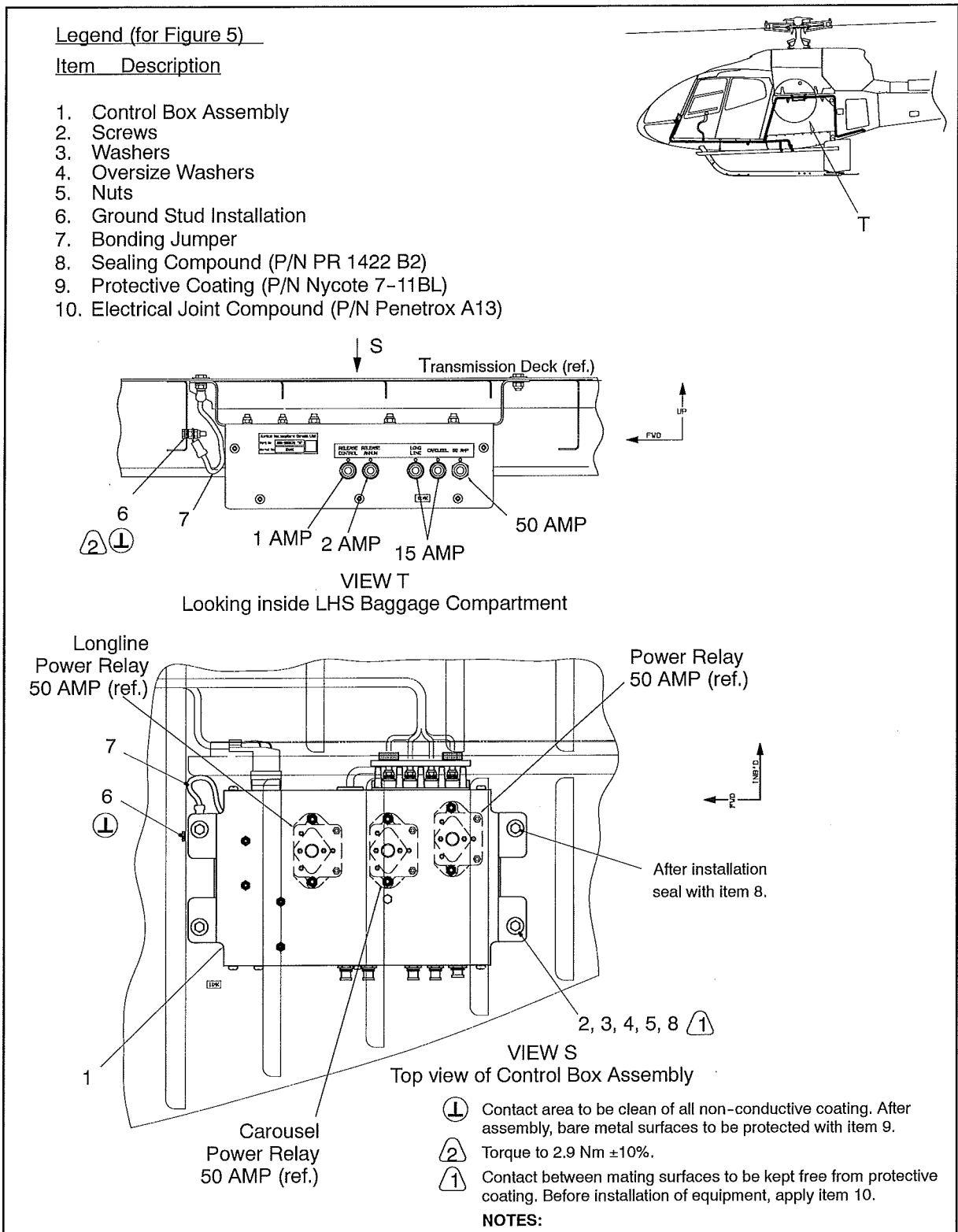

Figure 5 50 AMP/Longline/Carousel Control Box Assembly

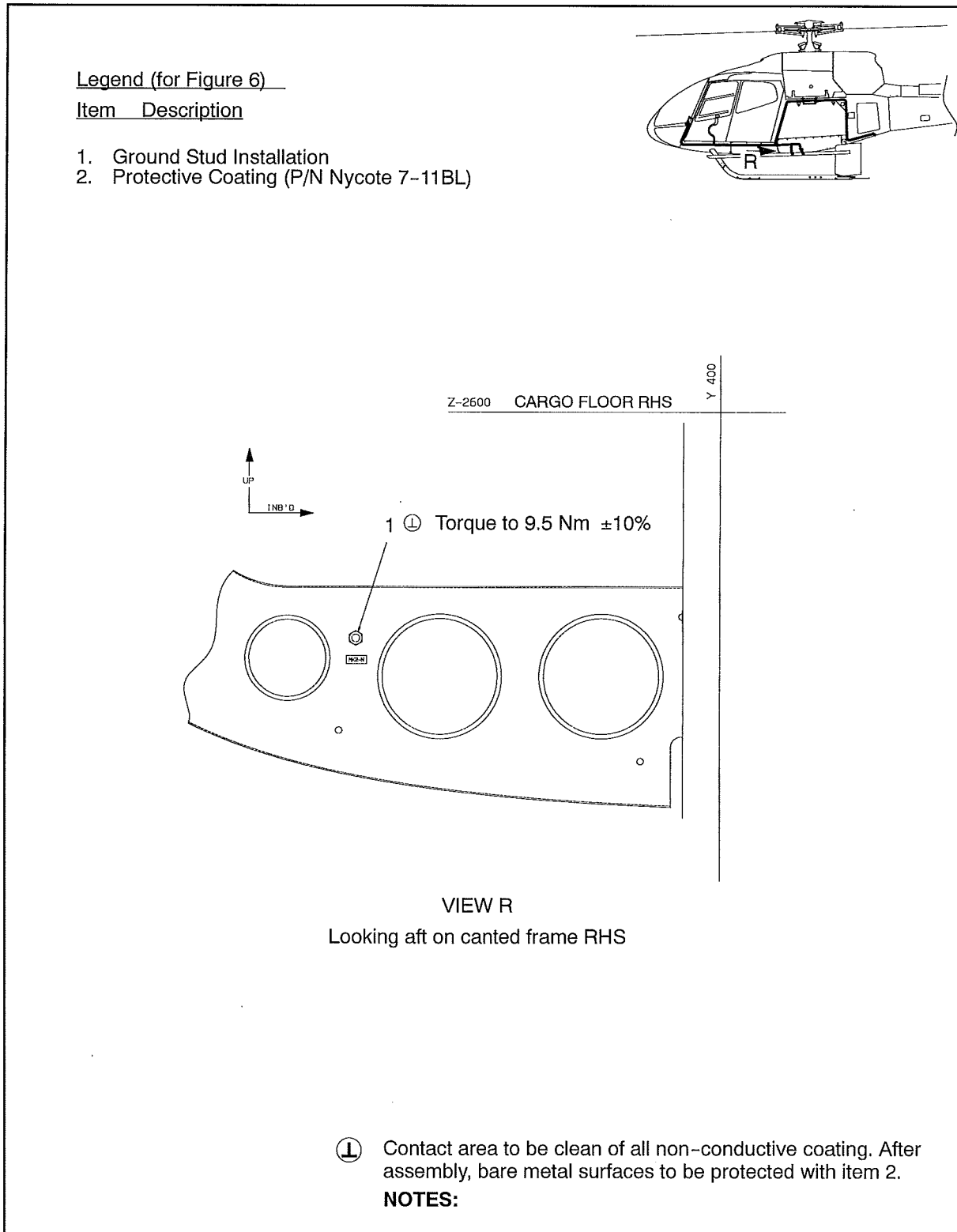

Figure 6 Ground Stud installation

**AIRBUS HELICOPTERS CANADA LIMITED**
**C. REFERENCES**

DOCUMENT	DOCUMENT TITLE
AC43.13-1B	Advisory Circular
AMM	Aircraft Maintenance Manual
FMS-AHCA-168	Flight Manual Supplement
IP-AHCA-140	Installation Instructions
MTC	Standard Practices Manual

**D. ABBREVIATIONS & DEFINITIONS**

ABBREVIATION	DEFINITION
A	Ampere
ADS	Avionics Design Services
AH	Airbus Helicopters (France)
AHCA	Airbus Helicopters Canada Limited
AMP	Ampere
A/W	Airworthiness
CAR	Canadian Aviation Regulations
DAPM	Design Approval Procedure Manual
e.g.	for example
FAA	Federal Aviation Administration
FH	Flight Hours
FWD	Forward
H/C	Helicopter
i.a.w.	in accordance with
INB'D	Inboard
LHS	Left Hand Side
L.Line	Longline
M	Months
Nm	Newton meters
Para.	Paragraph
P/N	Part Number
P.O.	Post Office
ref.	reference
RHS	Right Hand Side
STC	Supplemental Type Certificate
TCCA	Transport Canada Civil Aviation
W	With

**E. UNITS OF MEASUREMENT**

ABBREVIATION / SYMBOL	UNIT OF MEASUREMENT
D	Days
hrs	hours
in	inch
kg	kilogram
lb	pound
m	meter
M	Months



**INSTRUCTIONS FOR CONTINUED AIRWORTHINESS  
ELECTRICAL POWER SUPPLY FOR OPTIONAL  
50 AMP/LONGLINE/CAROUSEL SYSTEM  
EC 130 T2**

**AIRBUS HELICOPTERS CANADA LIMITED**

**2. AIRWORTHINESS LIMITATIONS**

Canadian Approval

The Airworthiness Limitations section is approved by the Minister of Transport and specifies maintenance required by any applicable airworthiness or operating rule unless an alternative program has been approved by the Minister.

FAA Approval

The Airworthiness Limitations section is FAA approved per Article II of the Bilateral Aviation Safety Agreement (BASA 2000) and Section III, Para. 3.2.2 of the implementation procedures, 2008 and specifies inspections and other maintenance required under Sections 43.16 and 91.403 of the Federal Aviation Regulations unless an alternative program has been FAA approved.

EASA Approval

The airworthiness limitations section is approved and variations must also be approved.

No airworthiness limitations associated with this installation.

**3. CONTROL AND OPERATION**

Control and operation of the aircraft remains unchanged.

Two indicator switches are used for arming either the Longline/Carousel or the 50 AMP Power. Only one system may be selected ON at a time. The lower segment of the activated switch will light up AMBER to indicate the selected switch. Refer to Figure 3.

Once armed, the system can be operated using momentary switches on the pilot's cyclic. Another momentary switch located on the pilot's cyclic grip activates power for the Carousel. Refer to Section 1, Figure 2.

PILOT'S CYCLIC LONGLINE / CAROUSEL SYSTEM OPERATION  
 (Refer to Section 1, Figures 2 and 3)

LONGLINE/CAROUSEL, 50 AMP indicator switches	OFF, Green indicator lights are on
LONGLINE/CAROUSEL switch	Press; ON, AMBER armed light comes on
Cyclic lever	Flip lever down to access system from cyclic
Longline Momentary switch	Press and hold as required: power is activated while pressed
Carousel Momentary switch	Press and hold as required: power is activated while pressed
LONGLINE/CAROUSEL switch	Press; OFF, AMBER armed light goes off, Green indicator lights remains on

PILOT'S CYCLIC 50 AMP POWER SYSTEM OPERATION  
 (Refer to Section 1, Figures 2 and 3)

LONGLINE/CAROUSEL, 50 AMP indicator switches	OFF, Green indicator lights are on
50 AMP switch	Press; ON, AMBER armed light comes on
Cyclic lever	Flip lever down to access system from cyclic
50 AMP Momentary switch	Press and hold as required: power is activated while pressed
50 AMP switch	Press; OFF, AMBER armed light goes off, Green indicator light remains on

**NOTE** The ammeter should be monitored during 50 AMP operation. A label repeating this advisory is attached to the Instrument Panel in clear view of the pilot.

**4. INSPECTION SCHEDULE AND MAINTENANCE ACTION**

**NOTE:** Testing of the 50 AMP/Longline/Carousel System prior to every flight requiring the use of the 50 AMP/Longline/Carousel System is recommended.

**NOTE:** Use torque per MTC, Chapter 20.02.05.404, unless otherwise specified.

**4.1. INSPECTION SCHEDULE**

Pre-Flight Check (Before each flight requiring the 50 AMP/Longline/Carousel System)

Refer to the Flight Manual Supplement, FMS-AHCA-168.

**NOTE:** The "Pre-Flight Check" tasks can be carried out by a suitably trained pilot or maintenance personnel.

4.1.1. Every 150 FH or 12 M (Margin: 15 FH or 36 D) to coincide with the 150 FH or 12 M helicopter inspection, whichever occurs first:

ITEM	INSPECTION OR MAINTENANCE WORK	CORRECTIVE ACTION
A	- Check operation of the 50 AMP/Longline/Carousel System: a. Apply power to the Longline/Carousel Switch b. Apply power to the 50 AMP switch	a. If lamp fails to illuminate, refer to Chapter 6, Troubleshooting. b. If lamp fails to illuminate, refer to Chapter 6, Troubleshooting.
B	- Check existing mounting hardware, securing the indicator housing (2), to the aircraft shown in Figure 3, for: a. security	a. Secure as required.
C	- Check connection between wire harness and switch housing assembly (1) connector plugs shown in Figure 3, for: a. security	a. Secure as required.
D	- Check mounting hardware, items 3, 4 and 5 securing the dummy receptacle (9) and dust cap (8) to the connector bracket (1) as shown in Figure 4 for: a. security	a. Secure as required.
E	- Visually check sealing compound, (12), in dummy receptacle (9) as shown in Figure 4: a. Ensure receptacle is filled with sealing compound	a. If receptacle is not filled, remove remaining compound, clean receptacle and refill in accordance with MTC, Chapter 20-05-01-206.

Table 1 Inspection Schedule and Maintenance Action  
 (continued on following page)

**AIRBUS HELICOPTERS CANADA LIMITED**
**4. INSPECTION SCHEDULE AND MAINTENANCE ACTION (continued)**
**4.1. INSPECTION SCHEDULE**
**4.1.1. (continued)**

ITEM	INSPECTION OR MAINTENANCE WORK	CORRECTIVE ACTION
F	- Check mounting hardware, items 2, 3, 4 and 5 securing the control box assembly (1) under the transmission deck shown in Figure 5 for: a. security	a. Secure as required.
G	- Check ground stud installation (6), shown in Figure 5 for: a. security	a. Secure as required. Torque to 2.9 Nm $\pm$ 10%.
H	- Check wire harness connection to control box assembly (1), shown in Figure 5 for: a. security	a. Secure as required.
I	- Check ground stud (1) shown in Figure 6 for: a. security	a. Secure as required. Torque to 9.5 Nm $\pm$ 10%.
J	- Check placards and markings (refer to Section 10) for: a. legibility b. secure mounting	a. If placard has become illegible, contact AHCA for replacement parts. b. Secure or reattach placards as required.

Table 1 Inspection Schedule and Maintenance Action

**4.1.2. Every 600 FH or 24 M (Margin: 60 FH or 73 D) to coincide with the 600 FH or 24 M helicopter inspection, whichever occurs first:**

ITEM	INSPECTION OR MAINTENANCE WORK	CORRECTIVE ACTION
A	- Visually check removable aft belly panel, shown in Figure 4 for: a. delamination	a. Repairs may be accomplished in accordance with MTC, Chapters 20.03.06.401, Section 401, C and 20.03.07.101 .  Reapply adhesive (16), scuff area to be primed once adhesive has dried. Finish paint inside surface with primer (14) and polyurethane paint (15) (G1001 Gamma Grey).

Table 2 Inspection Schedule and Maintenance Action

**AIRBUS HELICOPTERS CANADA LIMITED**
**4. INSPECTION SCHEDULE AND MAINTENANCE ACTION (continued)**
**4.1. INSPECTION SCHEDULE**
**4.1.3. Unscheduled Maintenance:**

ITEM	INSPECTION OR MAINTENANCE WORK	CORRECTIVE ACTION
A	- In the event of a hard landing incident: a. inspect aircraft i.a.w. MET	a. Refer to AMM, Chapter 05-50-00, 6-5.
B	- In the event of a lightening strike incident: a. inspect aircraft i.a.w. MET:	a. Refer to AMM, Chapter 05-50-00, 6-10.

Table 3 Inspection Schedule and Maintenance Action

**5. REPLACEMENT COMPONENTS AND REPAIR / OVERHAUL INFORMATION**

Contact AHCA for replacement parts. No overhaul information required for this installation.

For replacement components contact:

 Airbus Helicopters Canada Limited  
 1100 Gilmore Road, P.O. Box 250  
 Fort Erie, Ontario L2A 5M4 Canada  
 Telephone: (905) 871-7772  
 Telefax: (905) 871-3599  
[www.airbushelicopters.ca](http://www.airbushelicopters.ca)



**AIRBUS HELICOPTERS CANADA LIMITED**
**6. TROUBLESHOOTING**

For electrical system troubleshooting, refer to Figures 7, 8 and 9 for the 50 AMP/Longline/Carousel System, Wiring Diagrams.

No.	Trouble / Symptom	Probable Cause	Corrective Action
1	Either the Longline/Carousel or the 50 AMP Switch lamp does not illuminate during Daily Preflight Inspection	Indicator light defective:  Longline/Carousel (30MK)  50 Amp Switch (31MK)	Check indicator light and replace if defective:  - Longline/Carousel P/N LED-42-15-BB-EOUFN  - 50 Amp Switch P/N LED-42-15-BB-EOUFP
2		Fuse (1MK) defective	Inspect and replace if defective P/N ANL-60
3		Break or short in circuit	Perform circuit continuity check and replace/repair wiring as applicable in accordance with AC 43.13-1B, Chapter 11, Section 1.

Table 4 Troubleshooting

Page left blank intentionally



AIRBUS HELICOPTERS CANADA LIMITED

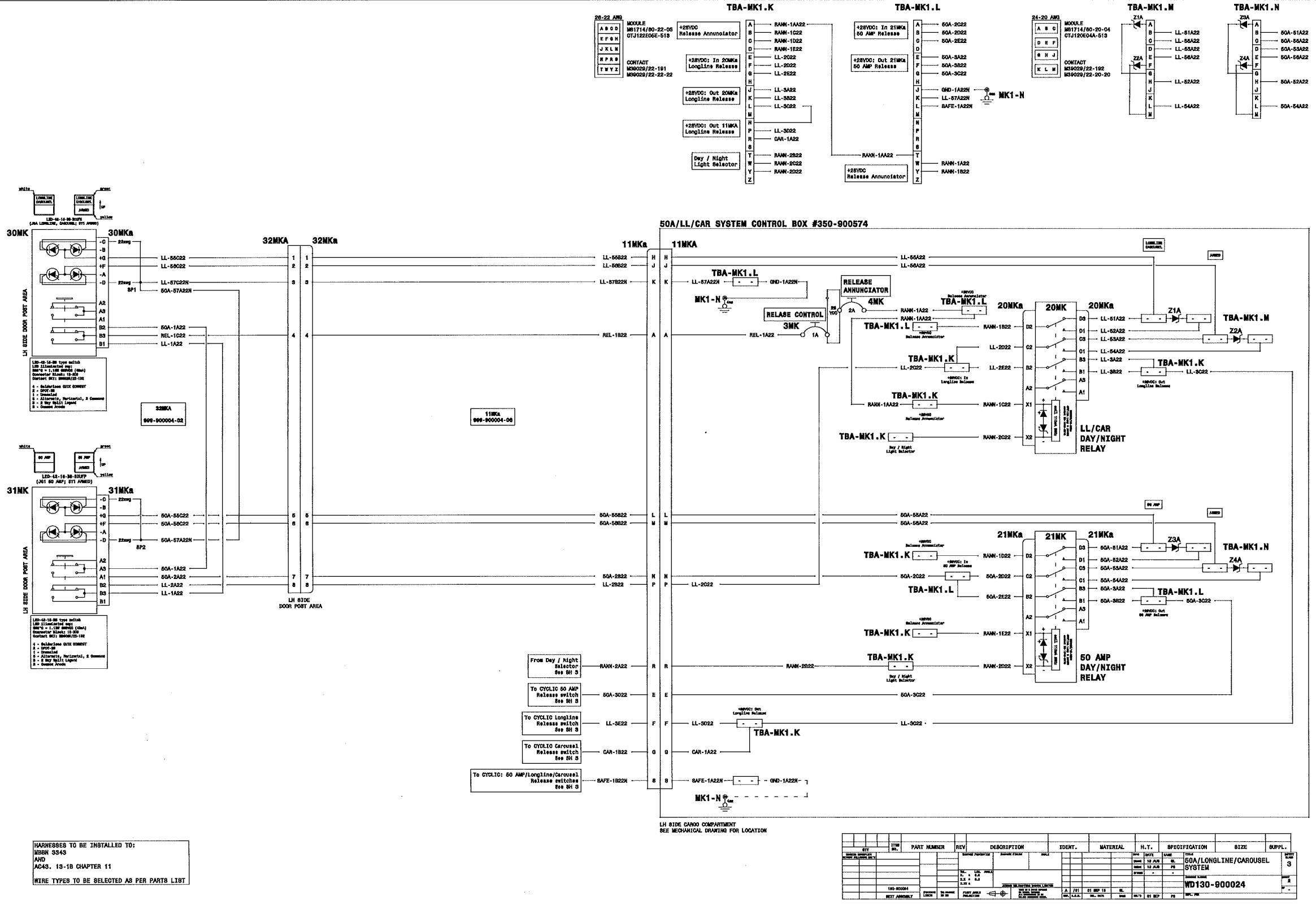
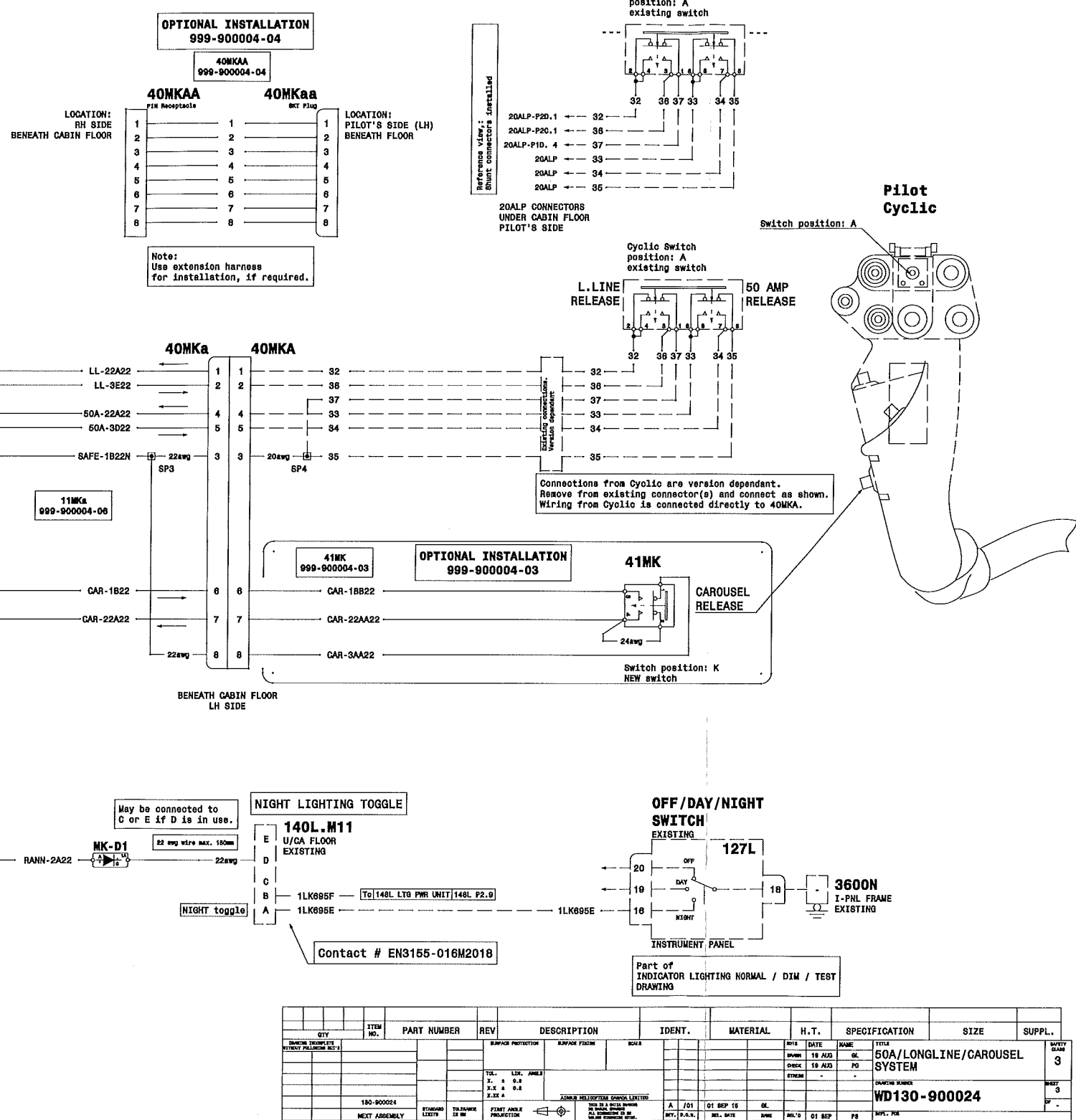

Figure 8 50 AMP/Longline/Carousel System, Wiring Diagram (continued)

Transport Canada Accepted



HARNESSES TO BE INSTALLED TO:  
MBBN 3343  
AND  
AC43. 13-1B CHAPTER 11  
WIRE TYPES TO BE SELECTED AS PER PARTS LIST

LH SIDE CARGO COMPARTMENT  
SEE MECHANICAL DRAWING FOR LOCATION

Figure 9 50 AMP/Longline/Carousel System, Wiring Diagram (continued)



AIRBUS HELICOPTERS CANADA LIMITED

INSTRUCTIONS FOR CONTINUED AIRWORTHINESS  
ELECTRICAL POWER SUPPLY FOR OPTIONAL  
50 AMP/LOGLINE/CAROUSEL SYSTEM  
EC 130 T2

Page left blank intentionally

**AIRBUS HELICOPTERS CANADA LIMITED****7. SPECIAL TOOLING**

No special test equipment or tools are required. Standard tools are adequate.

**8. REMOVAL AND REPLACEMENT**

## PRELIMINARIES

- Comply with General Safety Instruction – Electrical Power Supply System, EC 130 T2, AMM, Chapter 24-00-00, 3-1.
- Disconnect the battery i.a.w EC 130 T2, AMM, Chapter 24-33-00, 4-1.
- Disconnect the external power i.a.w EC 130 T2, AMM, Chapter 24-00-00, 2-1.
- Open any circuit breakers/fuses associated with the 50 AMP/Longline/Carousel System as shown in Section 1, Figures 1 and 5.
- If removing the belly connectors, remove the aft lower fairings i.a.w. EC 130 T2, AMM, Chapter 53.51.00. 4-2; Removal of lower fairings.

## REMOVAL

## 1) BELLY CONNECTORS (Refer to Section 1, Figure 4)

## Dummy Receptacle

- a) Remove screws (3, 4 places), washers (4, 4 places) and nuts (5, 4 places) securing the dummy receptacle (9) to connector bracket (1).

**NOTE:** Ensure that the dust cap (8) is secured to the dummy receptacle (9) before removal.

## Straight Connector

- a) Disconnect dust cap (8) if connected.
- b) Remove screws (3, 4 places), washers (4, 4 places) and nuts (5, 4 places) securing straight connector (6) to connector bracket (1).

## 2) CONTROL BOX ASSEMBLY (Refer to Section 1, Figure 5)

- a) Remove the wiring connector and disconnect wires from terminal strip.
- b) Remove screws (2, 4 places), washers (3, 4 places), oversize washers (4, 4 places), nuts (5, 4 places) and bonding jumper (7).securing control box assembly (1) to the inside of the LHS baggage compartment.

**8. REMOVAL AND REPLACEMENT (continued)**

## REPLACEMENT

**NOTE** Use torque per MTC, Chapter 20.02.05.404,  
unless otherwise specified.

Comply with general safety instructions for mechanical assemblies – AMM, Chapter 60-00-00, 3-1

Comply with general methods of applying sealing compounds – MTC, Chapter 20-05-01-102

Comply with general rules for bonding with adhesives – MTC, Chapter 20-06-01-101

Comply with Application of PR 1422 Class B sealant – MTC, Chapter 20-05-01-206

Comply with Electrical Bonding – MTC, Chapter 20.02.07.101

**1) BELLY CONNECTORS (Refer to Section 1, Figure 4)**

Dummy Receptacle

- a) Reposition the dummy receptacle (9) onto connector bracket (1) and secure using screws (3, 4 places), washers (4, 4 places) and nuts (5, 4 places).

Straight Connector

- a) Reposition straight connector (7) onto connector bracket (1) and secure using screws (3, 4 places), washers (4, 4 places) and nuts (5, 4 places).

**2) CONTROL BOX ASSEMBLY (Refer to Section 1, Figure 5)**

- a) Realign control box assembly (1) mounting holes with the holes in the transmission deck inside the LHS baggage compartment.

- b) Secure control box assembly (1) using screws (2, 3 places), washers (3, 3 places), oversize washers (4, 3 places) and nuts (5, 3 places).

**NOTE:** Contact between mating surfaces to be kept free from protective coating.  
Before installation of equipment, apply electrical joint compound (10).

**NOTE:** Seal screws (2) and oversize washers (4) with sealing compound (8).

- c) Secure bonding jumper (7) to control box assembly (1) using screw (2, 1 place), washer (3, 1 place) oversize washer (4, 1 place) and nut (5, 1 place).

**NOTE:** Contact between mating surfaces to be kept free from protective coating.  
Before installation of equipment, apply electrical joint compound (10).

- d) Seal screw (2), washer (3) and oversize washer (4) with sealing compound (8) at bonding jumper (7) location.

- e) Connect ground stud installation (6) at existing hole location. Torque to 2.9 Nm  $\pm$ 10%.

**NOTE:** Contact area to be clean of all non-conductive coating. After assembly,  
bare metal surfaces to be protected with protective coating (9).

- f) Reconnect wiring connector and wires to terminal strip.



**AIRBUS HELICOPTERS CANADA LIMITED**
**8. REMOVAL AND REPLACEMENT (continued)**

## REPLACEMENT

- 3) Close all circuit breakers/fuses opened for service in the PRELIMINARIES paragraph of this section.
- 4) Apply external power unit i.a.w. EC 130 T2, AMM, Chapter 24-00-00, 2-1.
- 5) Apply battery i.a.w. EC 130 T2, AMM, Chapter 24-33-00, 4-1.
- 6) Reference functional test - DC Power Supply System i.a.w. EC 130 T2, AMM, Chapter 24-30-00, 5-1.
- 7) Perform operational check of all systems that were serviced i.a.w. the EC 130 T2 procedures and the system's installation/operation manual.
- 8) If removed, install the aft lower fairing i.a.w. EC 130 T2, AMM, Chapter 53.51.00.4-2; Installation of lower fairings.

**9. WEIGHT AND BALANCE DATA**

A. <u>Removed Items</u>						
DESCRIPTION	WEIGHT		ARM		MOMENT	
	kg	lbs	m	in	kg m	lb in
Not applicable	0.00	0.0	0.00	0.0	0.00	0.0
<b>Total</b>	<b>0.00</b>	<b>0.0</b>	<b>0.00</b>	<b>0.0</b>	<b>0.00</b>	<b>0.0</b>

B. <u>Added Items</u>						
DESCRIPTION	WEIGHT		ARM		MOMENT	
	kg	lbs	m	in	kg m	lb in
Switch Housing Assembly	0.08	0.2	1.30	51.2	0.10	10.2
50 AMP/Longline/Control Box Assembly	2.08	4.6	3.45	135.8	7.18	624.7
Connector Bracket	0.05	0.1	3.10	122.0	0.16	12.2
Bonding Jumper	0.01	0.0	3.45	135.8	0.03	0.0
Dust Cap & Dummy Receptacle	0.05	0.1	3.10	122.0	0.16	12.2
Connector & Backshell	0.10	0.2	3.10	122.0	0.31	24.4
Harness	3.50	7.7	2.56	100.8	8.96	776.2
<b>Total</b>	<b>5.87</b>	<b>12.9</b>	<b>2.88</b>	<b>113.2</b>	<b>16.89</b>	<b>1459.9</b>

10. PLACARDS AND MARKINGS

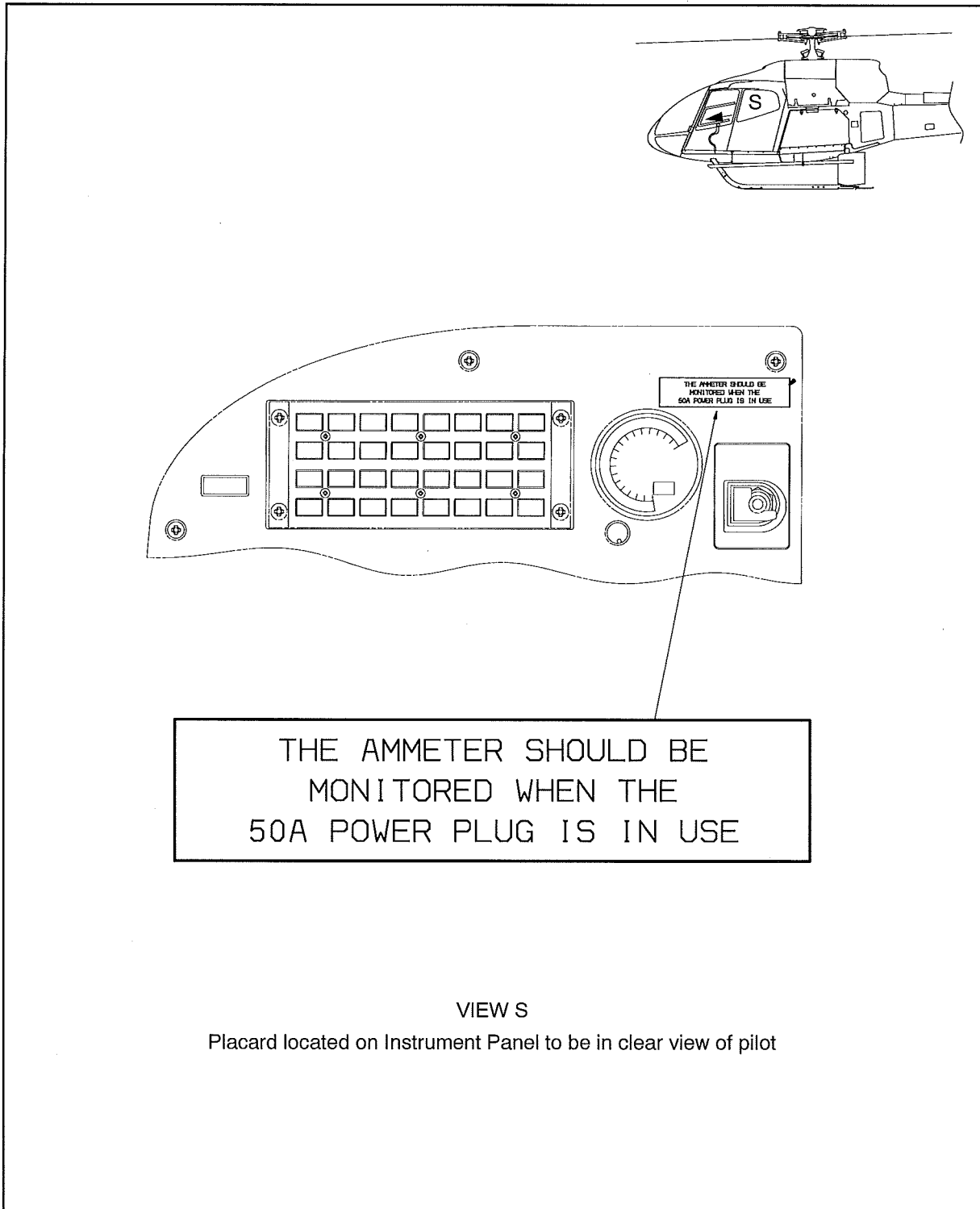

Figure 10 Typical placard location on the Instrument Panel

AIRBUS HELICOPTERS CANADA LIMITED

10. PLACARDS AND MARKINGS (continued)

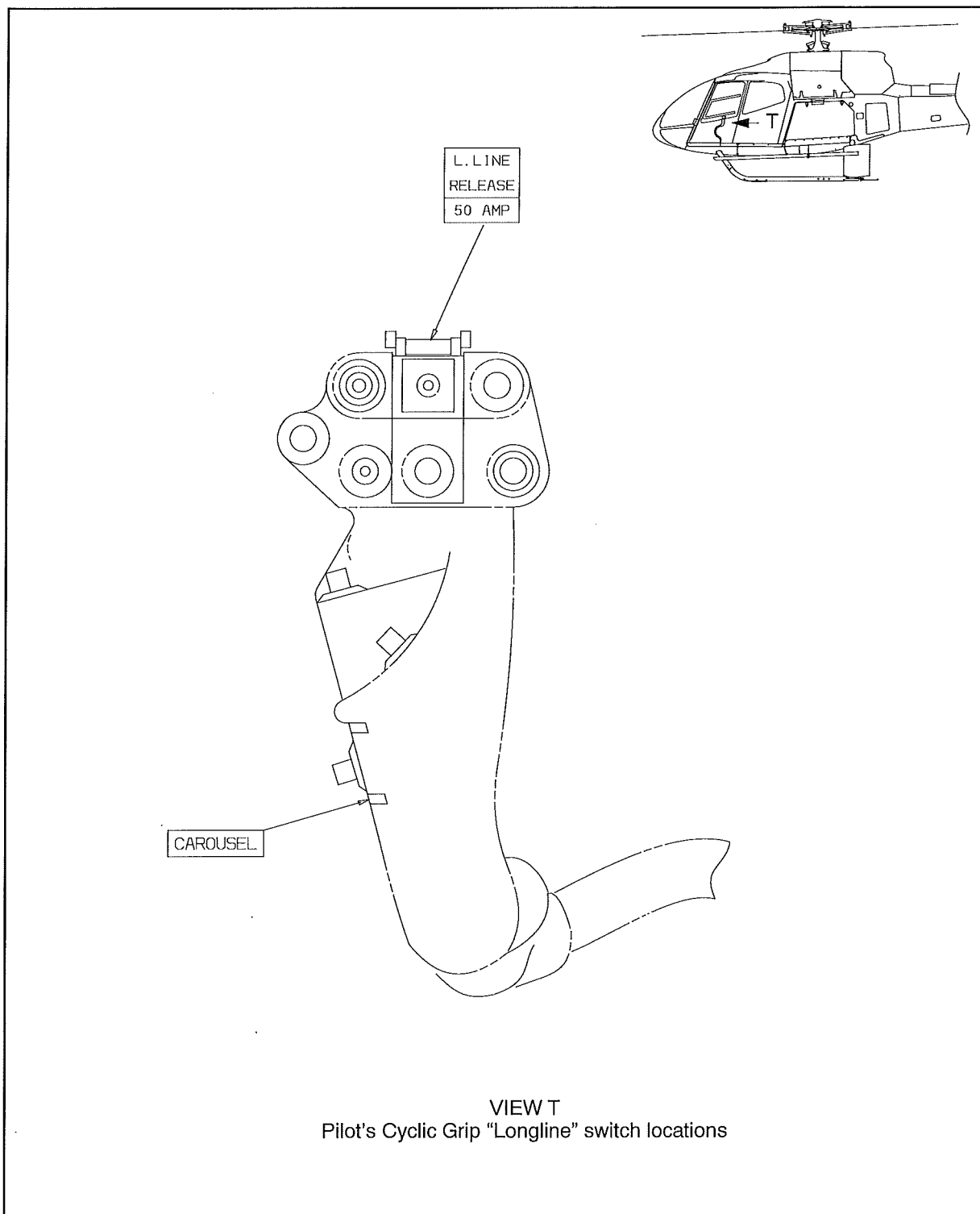

Figure 11 Labels located on Pilot's Cyclic Stick Grip

10. PLACARDS AND MARKINGS (continued)

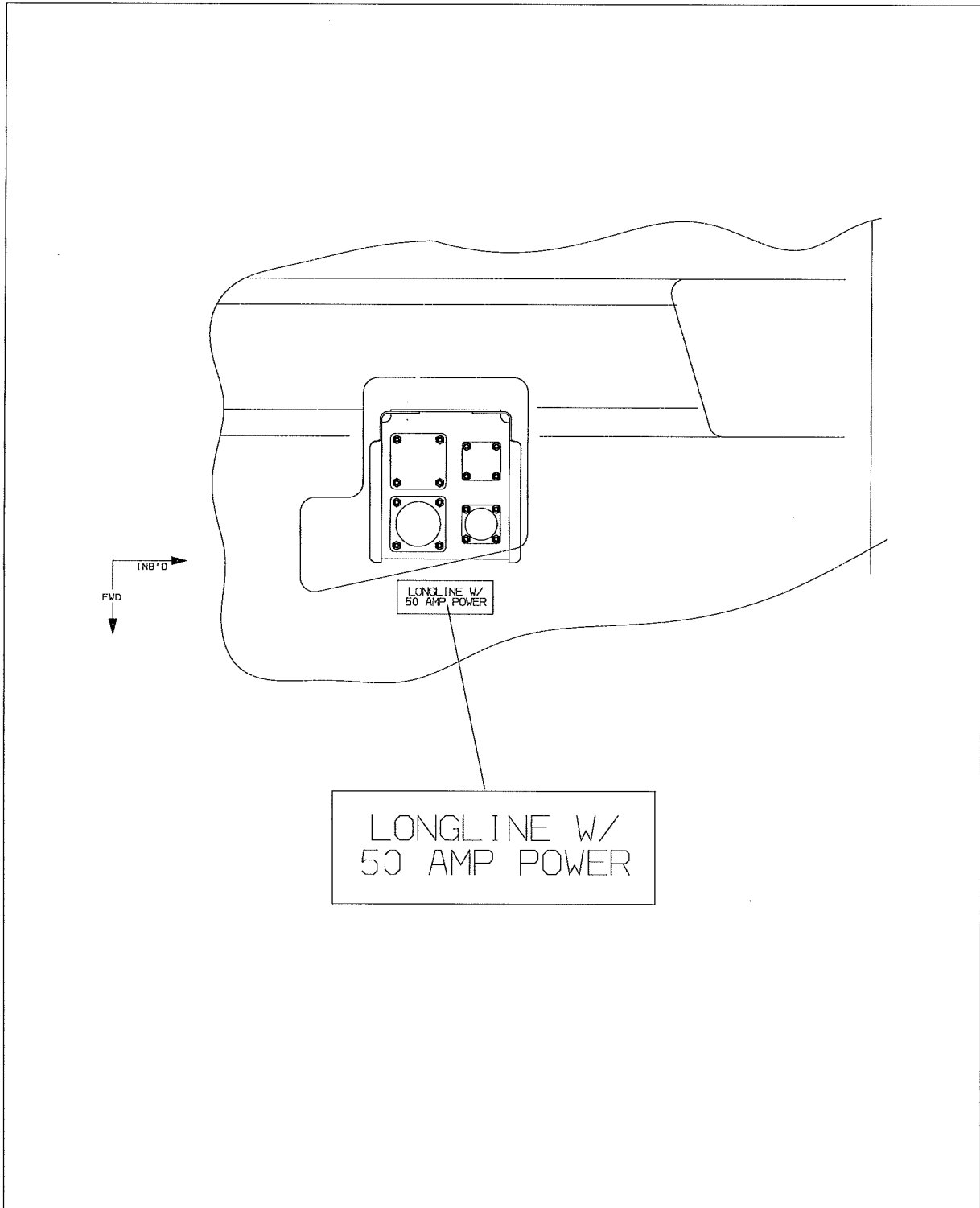

Figure 12 Label located on aft lower cowling