

**SUBJECT: SUPPLEMENTAL CABIN HEATER INSTALLATION  
 (P/N 145-90004 and 145-910004)**

The Supplemental Cabin Heater adds a heater to the passenger compartment supplementing the cabin heating during cold weather operations.

**APPLICABILITY:**

This Flight Manual Supplement must be used when the Supplemental Cabin Heater Installation is installed on the helicopter.

Department of Transport  
 (Canada) Approved

**IMPORTANT NOTE**

THE INFORMATION AND DATA CONTAINED IN THIS DOCUMENT SUPERSEDE OR SUPPLEMENT THAT CONTAINED IN THE BASIC APPROVED FLIGHT MANUAL FOR THE BK117 D-2, D-3 HELICOPTER IN THOSE AREAS LISTED HEREIN. FOR LIMITATIONS, PROCEDURES AND PERFORMANCE NOT CONTAINED IN THIS DOCUMENT REFER TO THE APPROVED FLIGHT MANUAL AND OTHER APPLICABLE APPROVED FLIGHT MANUAL SUPPLEMENTS.

SECTIONS 2, 3, 4 AND 5 OF THIS DOCUMENT COMPRISE THE APPROVED FLIGHT MANUAL SUPPLEMENT. COMPLIANCE WITH SECTION 2, LIMITATIONS, IS MANDATORY.

SECTIONS 1 AND 6 ARE UNAPPROVED AND ARE PROVIDED FOR INFORMATION ONLY.

THE INFORMATION CONTAINED IN THIS DOCUMENT SHALL BE TREATED AS THE PROPERTY OF AIRBUS HELICOPTERS CANADA LIMITED (AHCA). THE RECIPIENT OF THIS DOCUMENT SHALL NOT DISCLOSE ANY INFORMATION CONTAINED HEREIN TO THIRD PARTIES WITHOUT THE WRITTEN PERMISSION OF AHCA, AND SHALL NOT USE OR REPRODUCE THIS DOCUMENT IN WHOLE OR IN PART FOR ANY PURPOSE OTHER THAN ITS ORIGINALLY INTENDED PURPOSE, OR TO EVALUATE ITS CONTENTS.

	NAME AND SIGNATURE	DATE	COMPANY DEPARTMENT
PREPARED BY:	<b>Deborah Kerr</b>	Digitally signed by Deborah Kerr Date: 2021.09.16 09:19:00 -04'00'	AHCA ENGINEERING
PREPARED BY:			
CHECKED BY:	<b>Gary Krebs</b>	Digitally signed by Gary Krebs Date: 2021.09.21 12:08:52 -04'00'	AHI TEST PILOT
CHECKED BY:	<b>Ethan Fortier</b>	Digitally signed by Ethan Fortier Date: 2021.09.16 10:07:58 -04'00'	AHCA ENGINEERING
REV. 1 ACCEPTED (Civil A/W Authority)	See stamp		TCCA
REV. 1 RELEASED BY:	<b>Loïc Meuret</b>	Digitally signed by Loïc Meuret Date: 2021.10.25 10:04:59 -04'00'	AHCA ENGINEERING



## CONTENTS

SECTION	TITLE	PAGE
1	GENERAL .....	4
2	LIMITATIONS .....	9
3	EMERGENCY PROCEDURES .....	9
4	NORMAL PROCEDURES .....	9
5	PERFORMANCE DATA .....	10
6	WEIGHT AND BALANCE .....	11

## FIGURES

FIGURE	TITLE	PAGE
1	Switch location on Overhead Panel .....	5
2	General Layout .....	6
3	Vent Cover details .....	7

Transport Canada - Approved

**1. GENERAL (unapproved)**

The Supplemental Cabin Heater Installation adds a heater to the passenger compartment supplementing the cabin heating during cold weather operations. The heater is operated by the pilot or copilot using a three position toggle switch (OFF/LO/HI) located in the overhead switch console. Selecting LO on the toggle switch utilizes the first 500W heater element and the fan. Selecting HI on the toggle switch adds the second 500W heater element to the circuit. Refer to Figure 1, VIEW Z.

The Supplemental Cabin Heater Installation is manufactured for the BK 117 D-2 and D-3:

Aircraft Model	Part Number	Assembly Number
BK 117 D-2	145-900004	145-900014
BK 117 D-3	145-910004	145-910014

The cabin heater assembly is attached to a support bar which is mounted in the aft LH window recess and secured to the existing rails. The Cabin Heater Support Assembly is not interchangeable between BK 117 D-2 and D-3. Refer to Figure 2, General Layout.

In accordance with the approved Flight Manual, for operation at very low temperatures, the cabin heating outlets must be blocked using metallic plates found in the cold weather kit. With the subject modification, an alternative “tools free” blocking plate is available. Refer to Figure 3.

Electrical Load Data for Supplemental Cabin Heater Installation for the BK 117 D-2 and D-3:

ELECTRICAL LOAD DATA FOR MODIFICATION							
CB or Fuse	Value	Bus	Equipment	28 VDC Load: amps			Notes
				5 sec.	2 min.	Cont.	
906HE: HTR EL 1	25A	NO.1 NON-ESS BUS	500W HEATER ELEMENT	19.5A	19.5A	19.5A	17A to 19.5A
907HE: FAN PWR 1	7.5A	NO.1 NON-ESS BUS	HEATER FAN + RELAY	1.8A	1.8A	1.8A	3.0 to 3.4A FAN load is shared = 1.7A RELAY = 100mA
910HE: HTR EL 2	25A	NO.2 NON-ESS BUS	500W HEATER ELEMENT	19.5A	19.5A	19.5A	17A to 19.5A
911HE: FAN PWR 2	7.5A	NO.2 NON-ESS BUS	HEATER FAN + RELAY	1.8A	1.8A	1.8A	3.0 to 3.4A FAN load is shared = 1.7A RELAY = 100mA

In LO mode, the load is 23A (19.5 + 3.4 + 0.1A).

When HI mode is selected the total load is 42.6A (23 + 19.5 + 0.1).

The FAN load is shared in HI mode only.

The Flight Crew is responsible to ensure the generator capacity is not exceeded. Refer to Limitations Section 2.



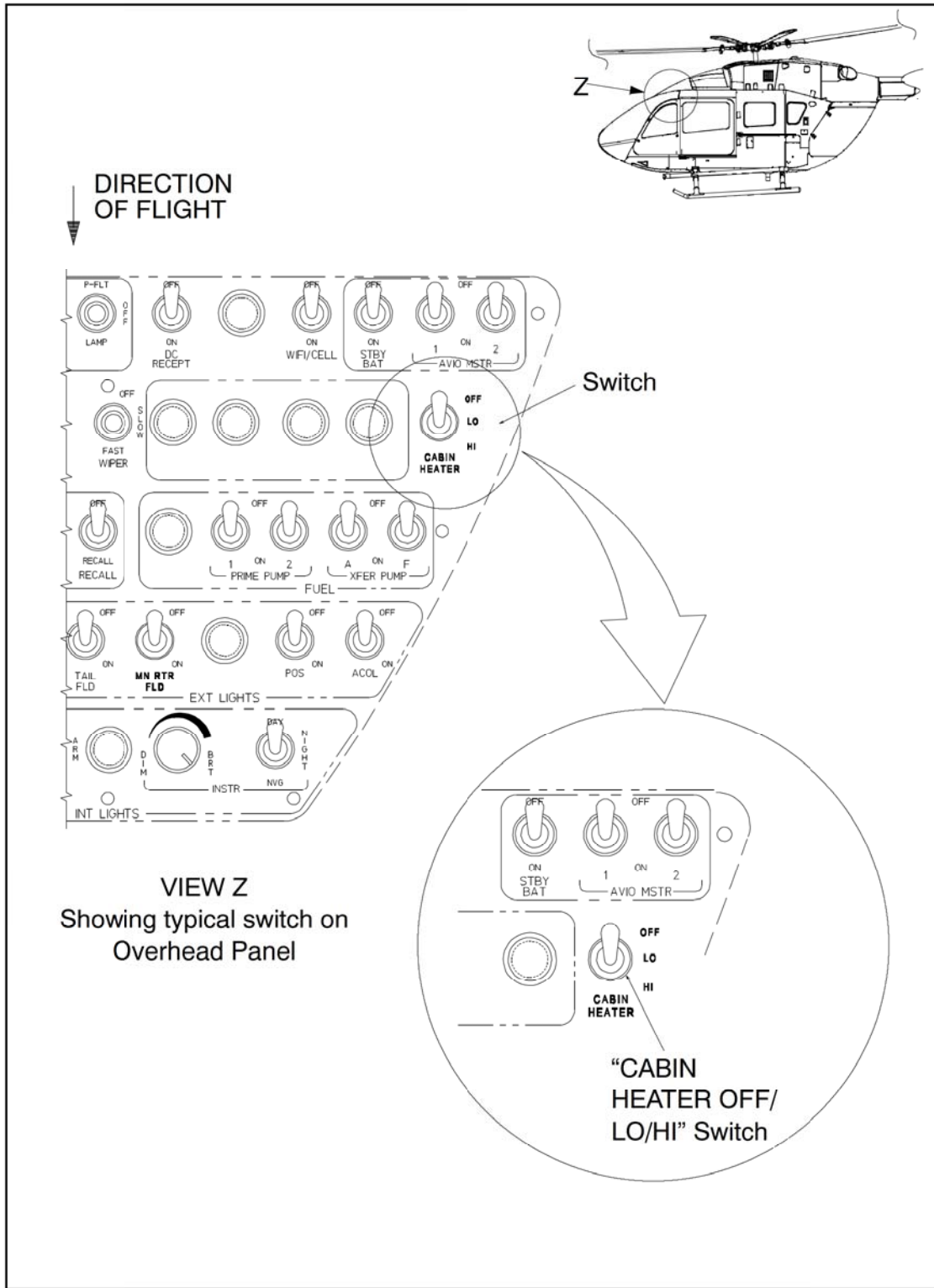

Figure 1 Switch Location on Overhead Panel

Transport Canada - Unapproved

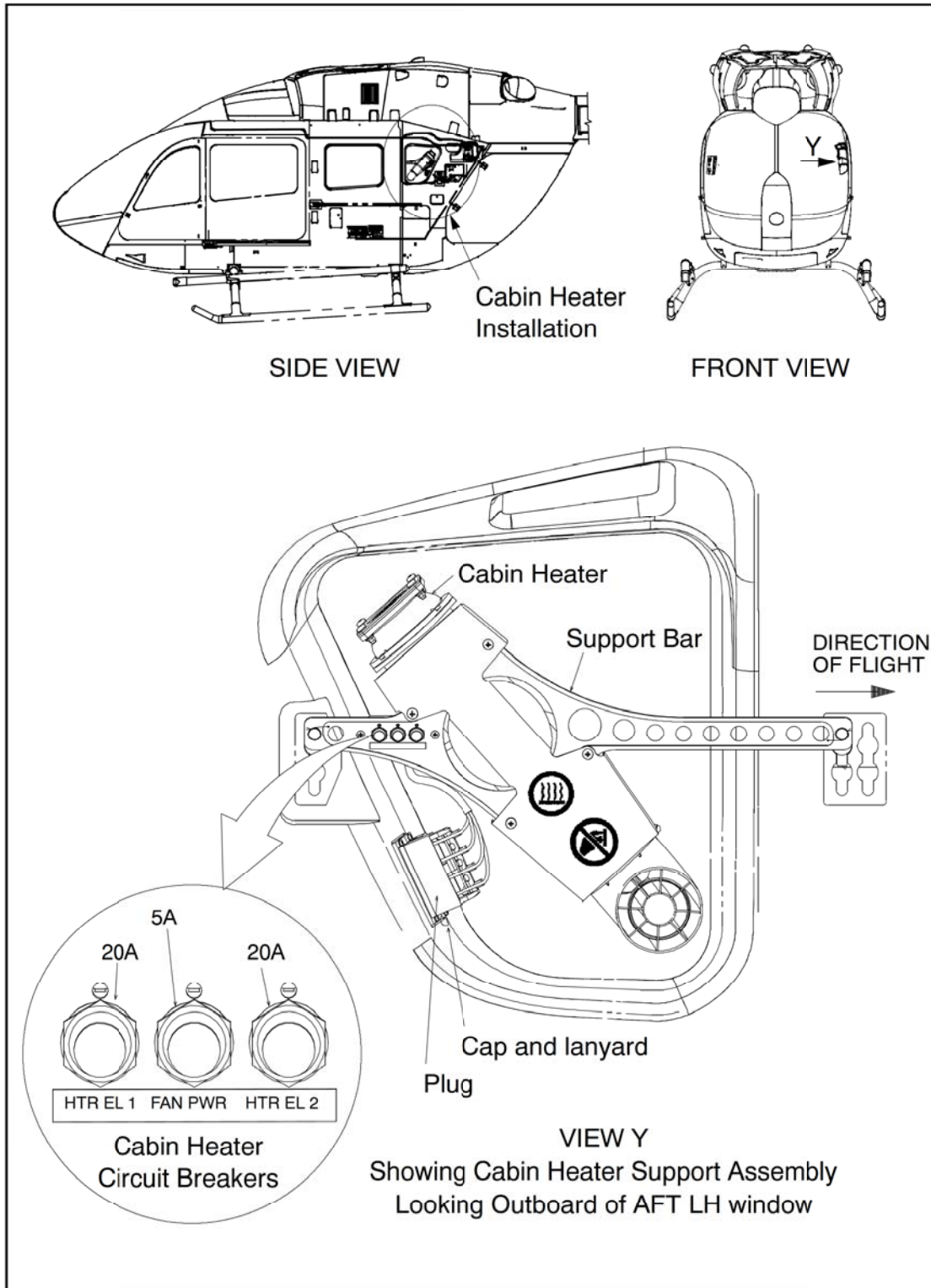

Figure 2 General Layout

Transport Canada - Unapproved

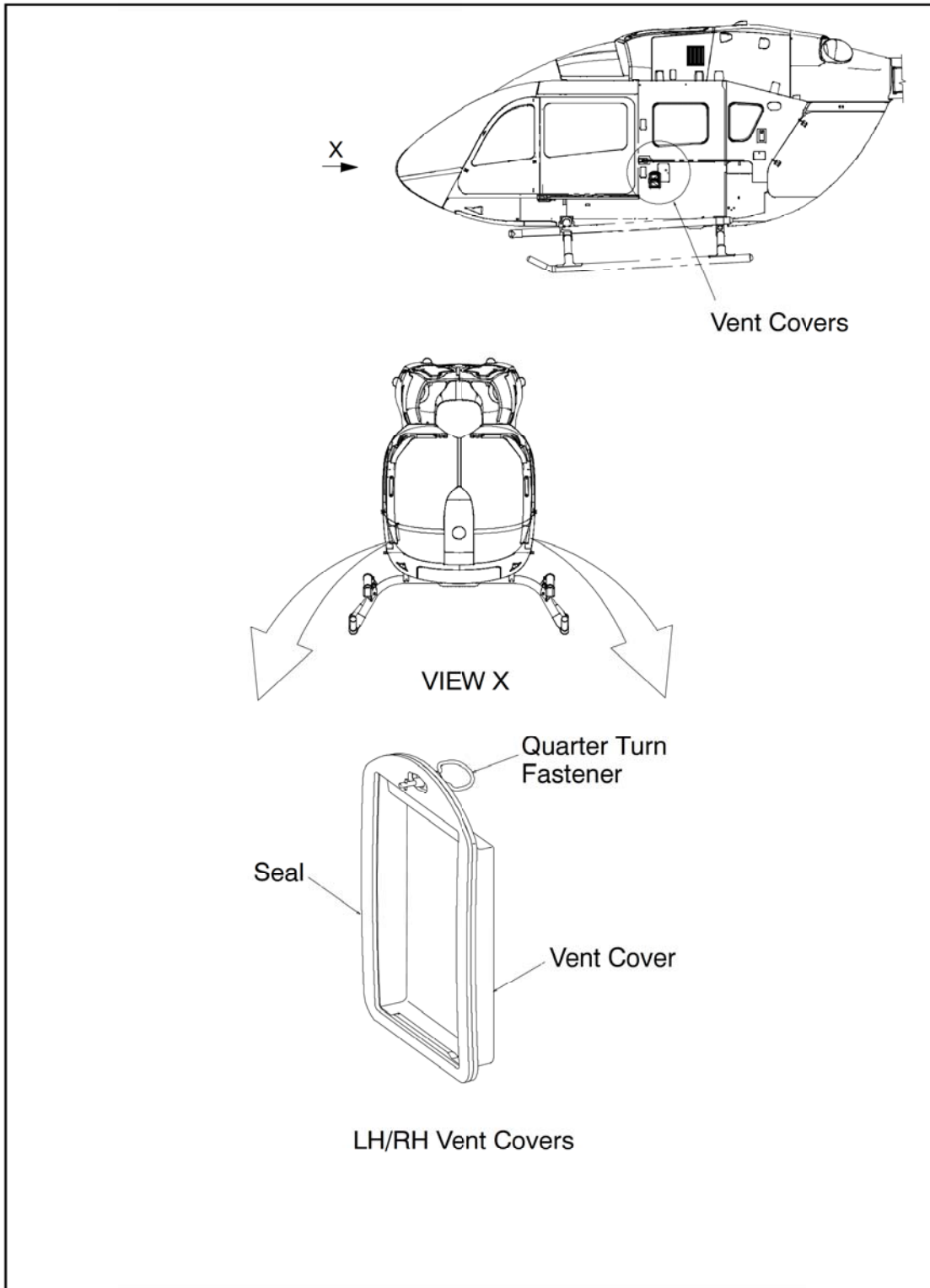

Figure 3 Vent Cover Details

Transport Canada - Unapproved

**1. GENERAL (unapproved) (continued)**

## Abbreviations and Definitions

ABBREVIATION	DEFINITION
A	Ampere
Acc'd	Accepted
AHCA	Airbus Helicopters Canada Limited
amps	ampere
App'd	Approved
A/W	Airworthiness
CAR	Canadian Aviation Regulations
CB	Circuit Breaker
Cont.	Continuous
DAPM	Design Approval Procedures Manual
FAN PWR	Fan Power
FMS	Flight Manual Supplement
HTR EL	Heater Element
HI	High
LH	Left Hand
LO	Low
mA	milliamperere
min.	minute
Non- Ess.	Non- Essential
OAT	Outside Air Temperature
P/N	Part Number
PWR	Power
Rev.	Revision
RH	Right Hand
Sec.	Seconds
STC	Supplemental Type Certificate
TCCA	Transport Canada Civil Aviation
VDC	Volts Direct Current
W	Watts

Transport Canada - Unapproved



## 2. LIMITATIONS

When simultaneously operating the Cabin Heat with EMS equipment or other heavy current loads, a generator overload condition may result. It is the responsibility of the flight crew to monitor the generator loads whenever operating the Cabin Heater System. In the event of electrical system abnormal or failure indication, follow the appropriate electrical load reduction procedures in the basic Flight Manual Emergency Procedures Section 3.

The following Limitation is applicable with this Cabin Heater Installation:

### a. Ambient air temperature limitations

The ambient air temperature limitations are unchanged with this modification. The optional LH/RH vent covers may be used in place of the metallic plates (part of the cold weather kit) required for blocking the cabin heating outlets at very low temperatures in accordance with the approved Flight Manual. Refer to Figure 3.

b. The Cabin Heater and the Air Conditioning must not be operated simultaneously.

## 3. EMERGENCY PROCEDURES

In addition to the procedure of the basic Flight Manual perform:

### a. Cabin fire

#### IN FLIGHT

CABIN HEATER switch - Select to power OFF  
(Refer to Figure 1)

### b. Electrical fire / short circuit

#### IN FLIGHT

CABIN HEATER switch - Select to power OFF  
(Refer to Figure 1)

AIRBUS HELICOPTERS CANADA LIMITED

**4. NORMAL PROCEDURES****a. Pre-Flight Check**

The following checks are to be carried out prior to every flight the Supplemental Cabin Heater is used:

CABIN HEATER (Refer to Figure 2) - Check for security

CABIN HEATER switch (Refer to Figure 1) - Check OFF position

**b. Operation**

1) CABIN HEATER (three position toggle switch, Refer to Figure 1)  
(Overhead Panel)

CABIN HEATER switch - Select LO or HI as required to power ON

CABIN HEATER switch - Select to power OFF

**5. PERFORMANCE DATA**

No change to existing Flight Manual.

Transport Canada - Approved

**6. WEIGHT AND BALANCE (UNAPPROVED)**

Total changes to weight and balance resulting from this modification are covered in the applicable Instructions for Continued Airworthiness.

Items that are removed between routine operations: Not applicable

Transport Canada - Unapproved