



AIRBUS HELICOPTERS CANADA LIMITED

INSTRUCTIONS FOR CONTINUED
AIRWORTHINESS
ENLARGED VERTICAL REFERENCE
WINDOW INSTALLATION
AS 350 / AS 355

SUBJECT:

Required maintenance for the Enlarged Vertical Reference Window Installation
(P/N 350-201154 and 355-201154).

APPLICABILITY :

Aircraft with the subject modification embodied in accordance with TCCA STC.
No. SH06-12 or any relevant foreign approvals.

THE INFORMATION CONTAINED IN THIS DOCUMENT SHALL BE TREATED AS THE PROPERTY OF AIRBUS HELICOPTERS CANADA LIMITED (AHCA). THE RECIPIENT OF THIS DOCUMENT SHALL NOT DISCLOSE ANY INFORMATION CONTAINED HEREIN TO THIRD PARTIES WITHOUT THE WRITTEN PERMISSION OF AHCA, AND SHALL NOT USE OR REPRODUCE THIS DOCUMENT IN WHOLE OR IN PART FOR ANY PURPOSE OTHER THAN ITS ORIGINALLY INTENDED PURPOSE, OR TO EVALUATE ITS CONTENTS.

	NAME AND SIGNATURE	DATE	COMPANY DEPARTMENT
PREPARED BY:	D. Kerr <i>DKerr</i>	15 Jan, 2015.	AHCA ENGINEERING
PREPARED BY:			
CHECKED BY:	C. Timmins <i>C. Timmins</i>	15 th Jan, 2015	AHCA ENGINEERING
CHECKED BY:	M. Merritt <i>M. Merritt</i>	JAN 15 2015	AHCA QUALITY ASSURANCE
REV. 5 ACCEPTED (Civil A/W Authority)	(As per ICA Compliance Check Sheet) <i>C. Timmins</i>	26 th Jan 2015	TCCA
REV. 5 RELEASED BY:	P. Sharpe <i>P. Sharpe</i>	JAN 28 2015	AHCA ENGINEERING

RECORD OF REVISIONS

Rev.	Pages at this Revision	Description, Reason Changed Pages	Prepared (name and date)	Checked (name and date)	App'd/Acc'd (Civil A/W Authority) (name and date)	Released (name and date)
0	1 through 27	Original Issue	D. Kerr 6 March 2006	C. Timmins 6 March 2006	TCCA J. Palmer 14 March 2006	R. Manson 20 March 2006
1	1 through 29	Revised to incorporate installation for the AS 355, Int. Belly Panel Mod lay-up revised. (Pages 3 to 7, 9 to 11, 13, 14, 17, 20, 22, and 24 to 29)	D. Kerr 2 June 2006	C. Timmins 2 June 2006	TCCA J. Palmer 13 July 2006	R. Manson 13 July 2006
2	1 through 34	Revised format. Description revised. Addition of NP variants. (Pages 3 to 7, 9 to 25, 27 to 34)	D. Kerr 2 July 2008	C. Timmins 2 July 2008	DAO R. Manson	R. Manson 9 July 2008
3	1 through 34	Figure references corrected in Section 4. Reduction in number of plys for ease of window installation and security. New part numbers referenced for Fibreglass cloth and adhesive. (Pages 10, 21 and 23)	D. Kerr 14 April 2010	C. Timmins 14 April 2010	DAO R. Manson 5 September 2008	C. Timmins 6 May 2013
4	1 through 36	Company name and logo changed. Illustration to show relocation of load meter with 50A/Long-line/Carousel System and MOD with RHS sliding door. Maintenance instruction and weight and balance chart revised. (Pages 3 to 6, 10 to 21 and 24 to 28)	D. Kerr 20 February 2014	C. Timmins 20 February 2014	TCCA G. David 23 July 2014	P. Sharpe 1 August 2014
5	1 through 37	Revision to incorporate the fire extinguisher relocation with the two-place front seat. Figure to show data plate relocation. Weight and Balance charts revised. Figure 14 illustration corrected. (Pages 3 to 6, 9, 14 to 18, 21 to 24 and 27 to 37)	See page 1.	See page 1.	See page 1.	See page 1.

NOTE: Revisions to this document will be distributed to operators of this equipment by the STC holder.

NOTE: Revised portions of affected pages are identified by a vertical black line in the margin adjacent to the change.

NOTE: Minor changes are released in accordance with TCCA - ACCEPTED CAR 521-154 procedures (ref. DAPM-E-0001).

Transport Canada Accepted

CONTENTS

SECTION	TITLE	PAGE
1	GENERAL	5
2	AIRWORTHINESS LIMITATIONS	18
3	CONTROL AND OPERATION	19
4	INSPECTION SCHEDULE AND MAINTENANCE ACTION	19
5	OVERHAUL REQUIREMENTS	22
6	TROUBLESHOOTING	22
7	SPECIAL TOOLING	25
8	REMOVAL AND REPLACEMENT	25
9	WEIGHT AND BALANCE DATA	27
10	PLACARDS AND MARKINGS	30

FIGURES

FIGURE	TITLE	PAGE
1	General Layout	6
2	Floor Window Cover	7
3	Forward and Intermediate Belly Panels	8
4	Fire Extinguisher Installation	9
5	Floor-Mounted Torque Indicator Option	10
6	Floor-Mounted Torque Indicator Option - (aircraft with reinforced floor shown) ..	11
7	Load Meter relocation with Enlarged Vertical Reference Window Installation	12
8	Enlarged Vertical Reference Window MOD with RHS Sliding Door (ESK-1295) .	13
9	Fire Extinguisher Installation	14
10	Forward Belly Panel MOD - Composite Lay-up	15
11	Intermediate Belly Panel MOD - Composite Lay-up	16
12	Wiring Diagram shown with Floor-Mounted Torque Indicator Option - to be used with Control Panel in Figure 15 (original diagram)	23
13	Wiring Diagram shown with Floor-Mounted Torque Indicator Option - to be used with Control Panel in Figure 16	24
14	Data Plate Relocation	30
15	Placards on Instrument Panel with Floor-Mounted Torque Indicator Option	31

(continued on following page)

Transport Canada - Accepted

FIGURES (continued)

FIGURE	TITLE	PAGE
16	Placards on Instrument Panel with Floor-Mounted Torque Indicator Option	32
17	Placards on Instrument Panel alternate location with Floor-Mounted Torque Indicator Option	33
18	Placards on fuse panel with Floor-Mounted Torque Indicator Option	34
19	Placards on alternative fuse panel with Floor-Mounted Torque Indicator Option	35
20	Placards FWD of center console in Nose Bay, LHS - with Floor-Mounted Torque Indicator Option	36
21	Placards on RHS bulkhead with Floor-Mounted Torque Indicator Option (aircraft with Floor Seat Rail Support shown)	37

TABLES

TABLE	TITLE	PAGE
1	Inspection Schedule and Maintenance Action Before the first flight of each day	19
2	Inspection Schedule and Maintenance Action Pre-Flight Check	19
3	Inspection Schedule and Maintenance Action Every 150 FH or 12 M (Margin: 15 FH or 36 D)	20
4	Troubleshooting Guide	22

Transport Canada - Accepted

AIRBUS HELICOPTERS CANADA LIMITED
1. GENERAL

- A. The Enlarged Vertical Reference Window is an optional window for the AS 350 / AS 355 mounted in the floor of the aircraft, just outboard of the pilot's seat, with a corresponding window in the belly panel. The enlarged window provides better pilot reference, as in long line operations. Refer to Figure 1.

This Instruction for Continued Airworthiness is applicable to aircraft with PRE AMS 07 3180 and POST AMS 07 3180, which makes the floor compatible with the pilot's and co-pilot's energy-absorbing seats.

The Enlarged Vertical Reference Window consists of the following main components:

COMPONENT	LOCATION
Vertical Reference Window Floor Mod	RHS cabin floor
FWD Belly Panel Mod	First cowling under fuselage
Intermediate Belly Panel Mod	Behind FWD belly panel
Torque Meter Mod	RHS under vertical reference window
Fire Extinguisher Relocation	Relocation depending on aircraft configuration and seat type

The belly panel window extends back beyond the aft edge of the lower front fairing. An extension is attached to the back of this fairing, on the right hand side. The front of the intermediate fairing is trimmed back by a similar amount. The landing light, which is located on the RHS of the intermediate fairing, is relocated lower and aft, to clear the enlarged window. Provisions for the light are included in the modifications to the intermediate panel. Refer to Figure 3.

This installation includes an option for a second torque indicator (AS 350 B2 without VEMD only), located where it is visible through the floor window. This allows the pilot to monitor the torque during long line operations. It is activated using a switch on the instrument panel, with selection for either the floor or panel mounted indicator. Refer to Figures 5 and 6.

For AS 350 B2/B3 that embody the 50A/Longline/Carousel System, which relocates the load meter to the floor window area. The longline switches are located on the instrument panel in clear view of pilot. Refer to Figure 7.

- NOTE:** The load meter cannot be installed in the vertical reference window if the second torque meter is already in the floor window area.

The fire extinguisher is relocated from its position in the basic aircraft to either:

- back of the pilot's seat (for aircraft with High Back Composite Seat Installation). Refer to Figure 1.
- or
- "AFT laterally" or "LEFT longitudinally" of the pilot's collective housing (for aircraft with energy-absorbing type seat installation). Refer to Figure 1, VIEW A.
- or
- "AFT longitudinally" of the pilot's collective housing (for aircraft with the two-place front seat, installed in accordance with STC SH93-72). Refer to Figure 1, VIEW B.
- or
- back of center console (for aircraft with energy-absorbing type seat installation and extended center console, AS 355 NP version). Refer to Figure 1, VIEW C.

The Data Plate is also relocated to the RHS of the aircraft exterior.

The AS 355 utilizes a smaller floor doubler than the AS 350. A floor window stiffener is also installed under the cabin floor just inboard of the floor window.

This revision introduces the Enlarged Vertical Reference Window with RHS Sliding Door which modifies the existing kick plate and adds a new stiffener under the existing sliding door track. Refer to Figure 8.

For instructions for initial installation, see IP-ECL-116.

- B. These Instructions for Continued Airworthiness are applicable to aircraft with the subject modification embodied.

Transport Canada Accepted

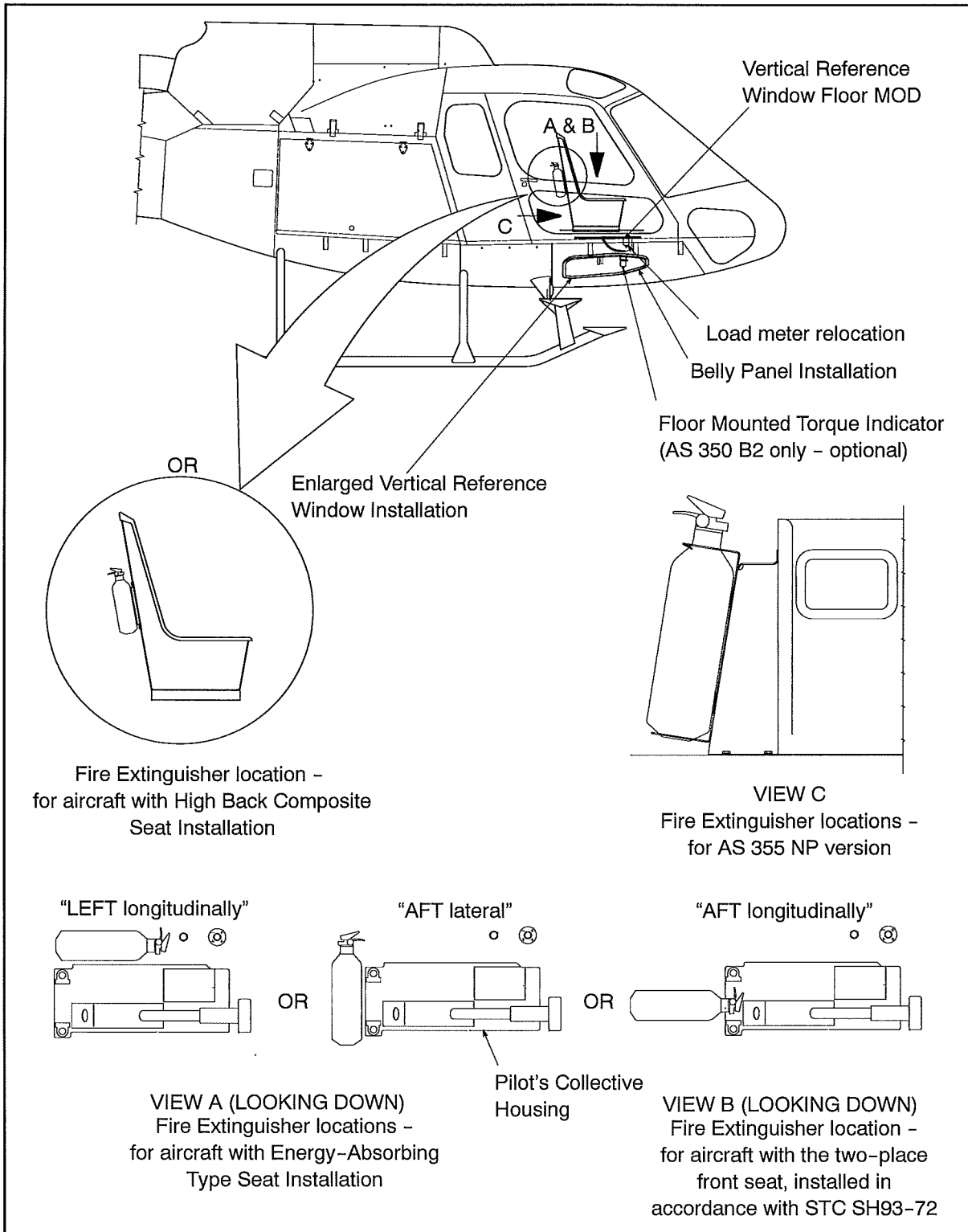

Figure 1 General Layout

Transport Canada Accepted

AIRBUS HELICOPTERS CANADA LIMITED

Figure 2 Floor Window Cover

Transport Canada Accepted

AIRBUS HELICOPTERS CANADA LIMITED

Legend (for Figure 3)

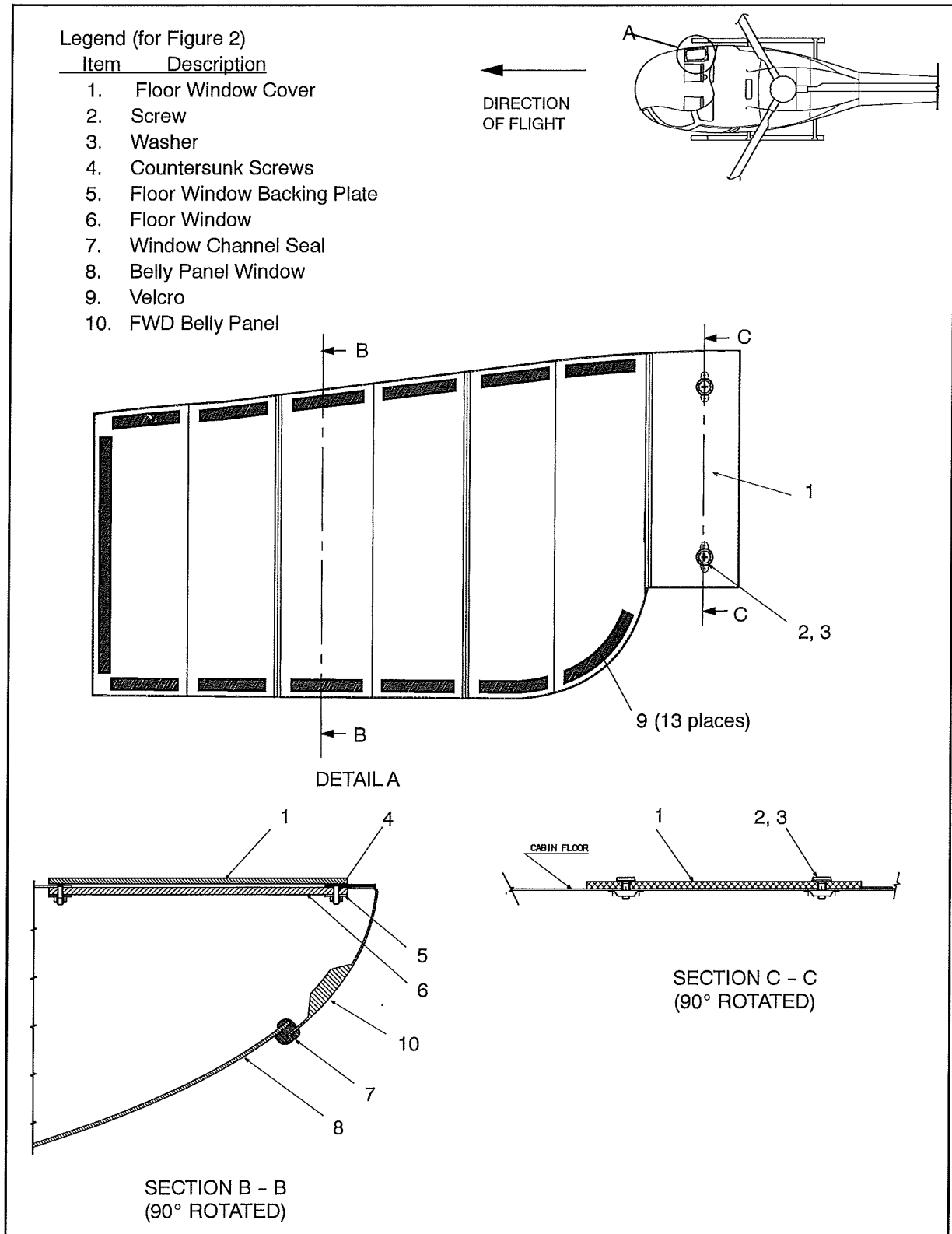
<u>Item</u>	<u>Description</u>
1.	Forward Belly Panel Mod
2.	Intermediate Belly Panel Mod

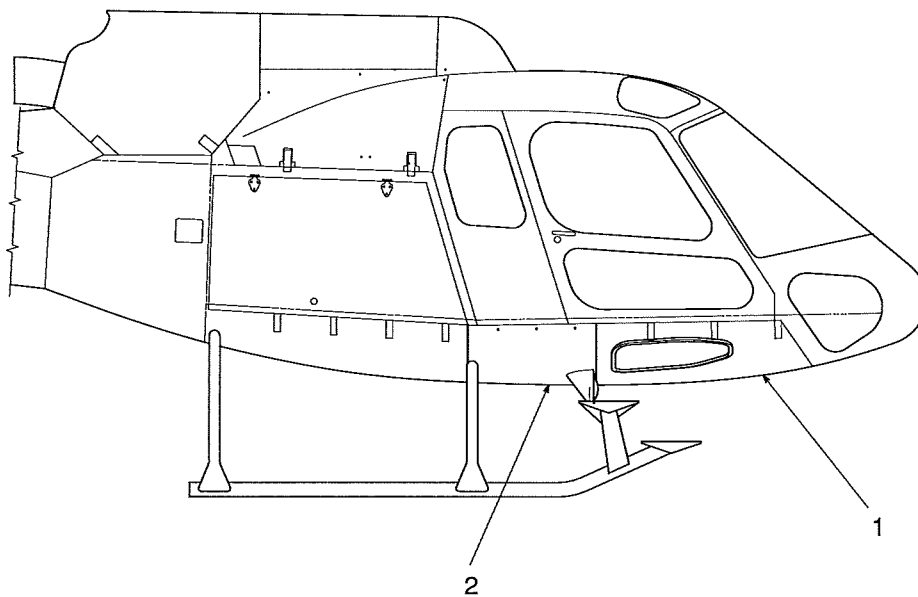

Figure 3 Forward and Intermediate Belly Panels

Transport Canada Accepted

AIRBUS HELICOPTERS CANADA LIMITED

Figure 4 Fire Extinguisher Installation

Transport Canada Accepted

AIRBUS HELICOPTERS CANADA LIMITED

Figure 5 Floor-Mounted Torque Indicator Option

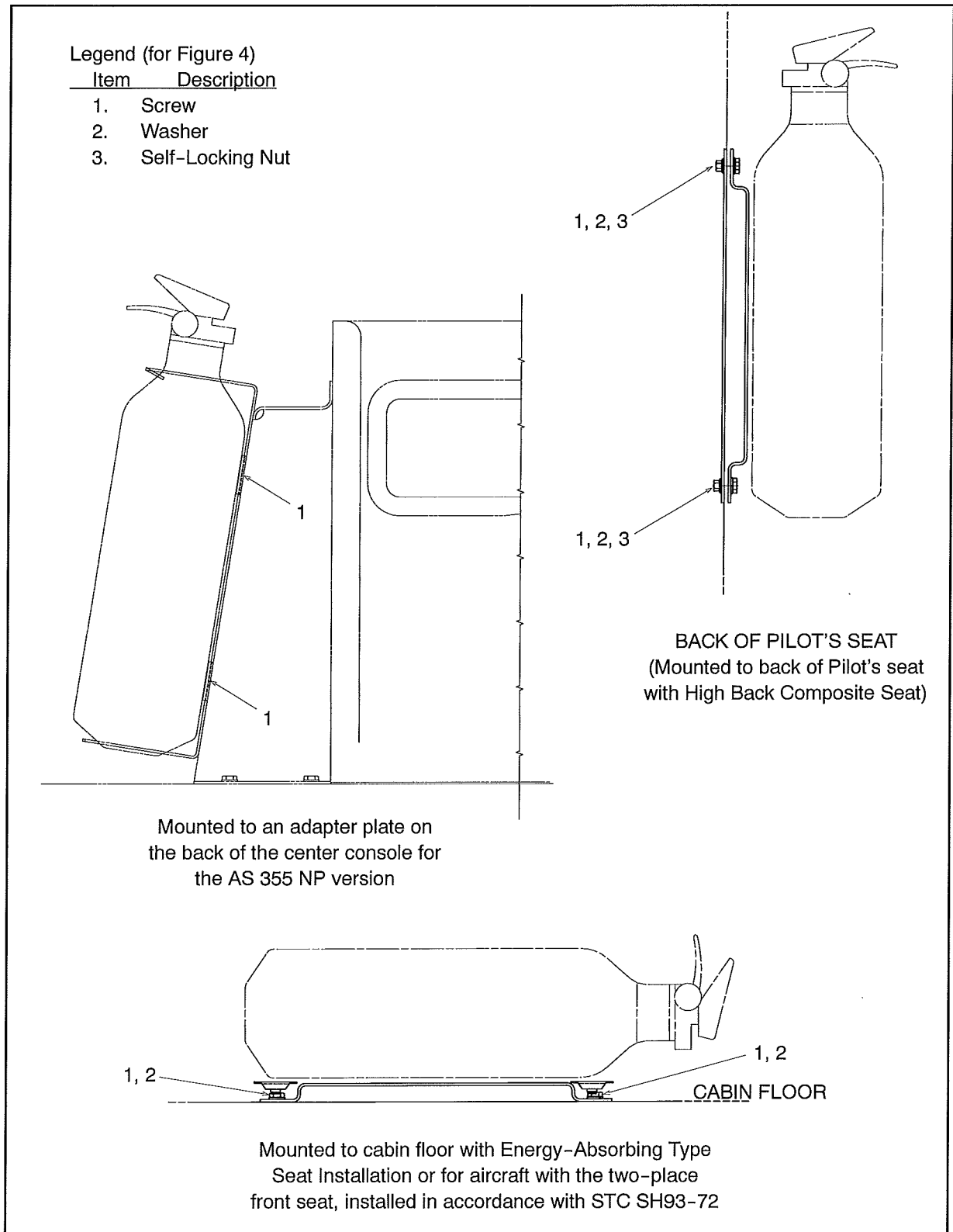
Transport Canada Accepted

AIRBUS HELICOPTERS CANADA LIMITED

Figure 6 Floor-Mounted Torque Indicator Option (aircraft with reinforced floor shown)

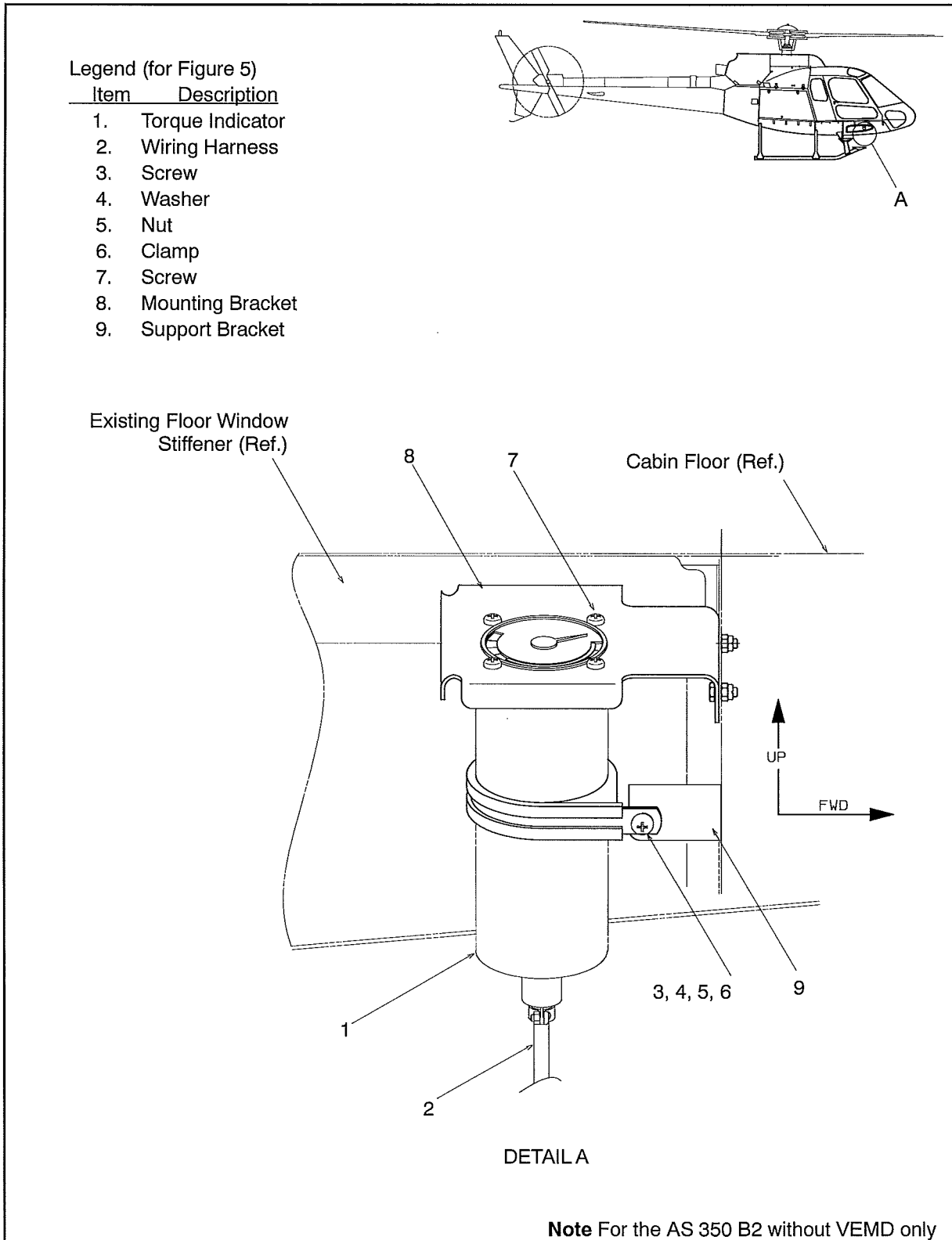
Transport Canada Accepted

AIRBUS HELICOPTERS CANADA LIMITED

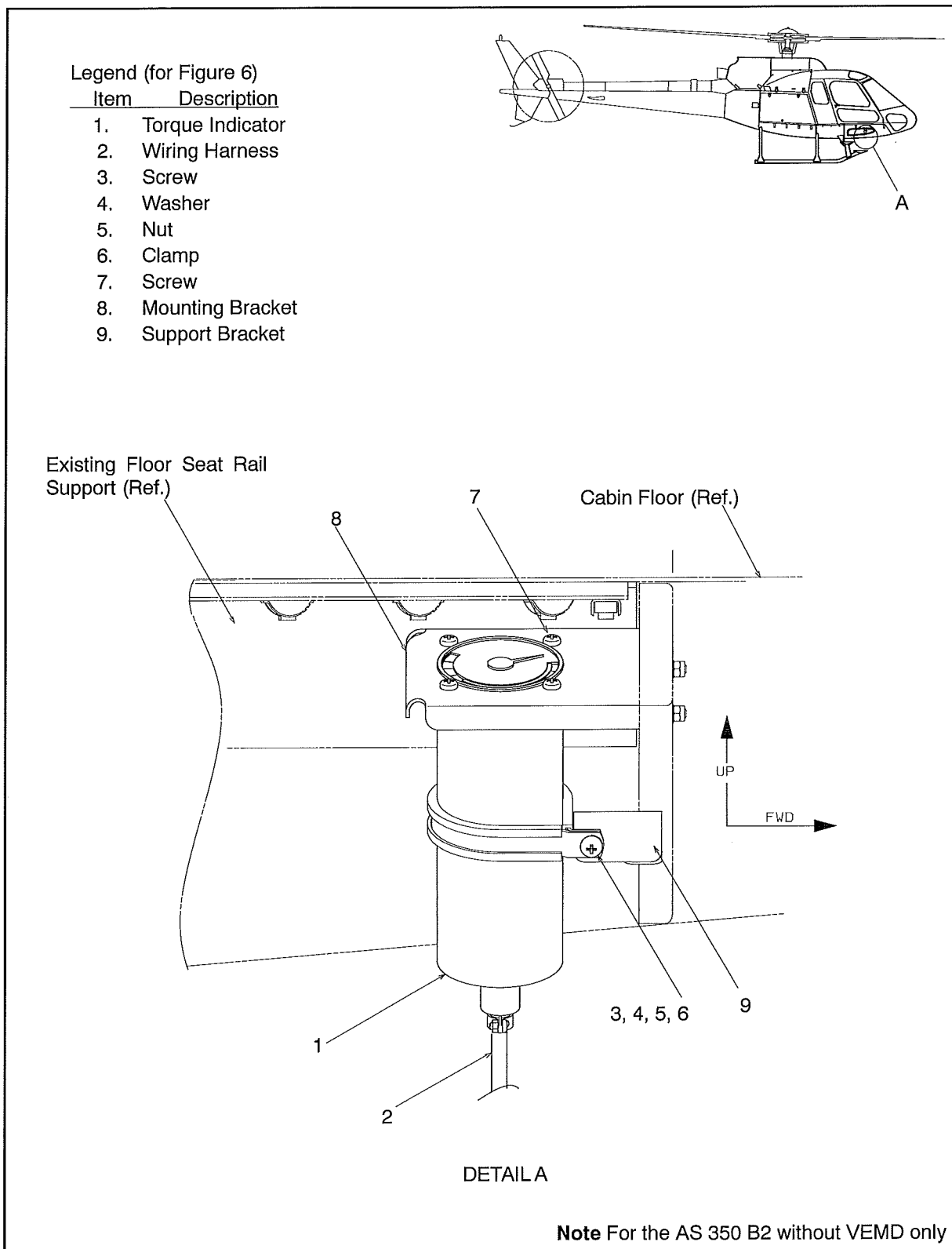
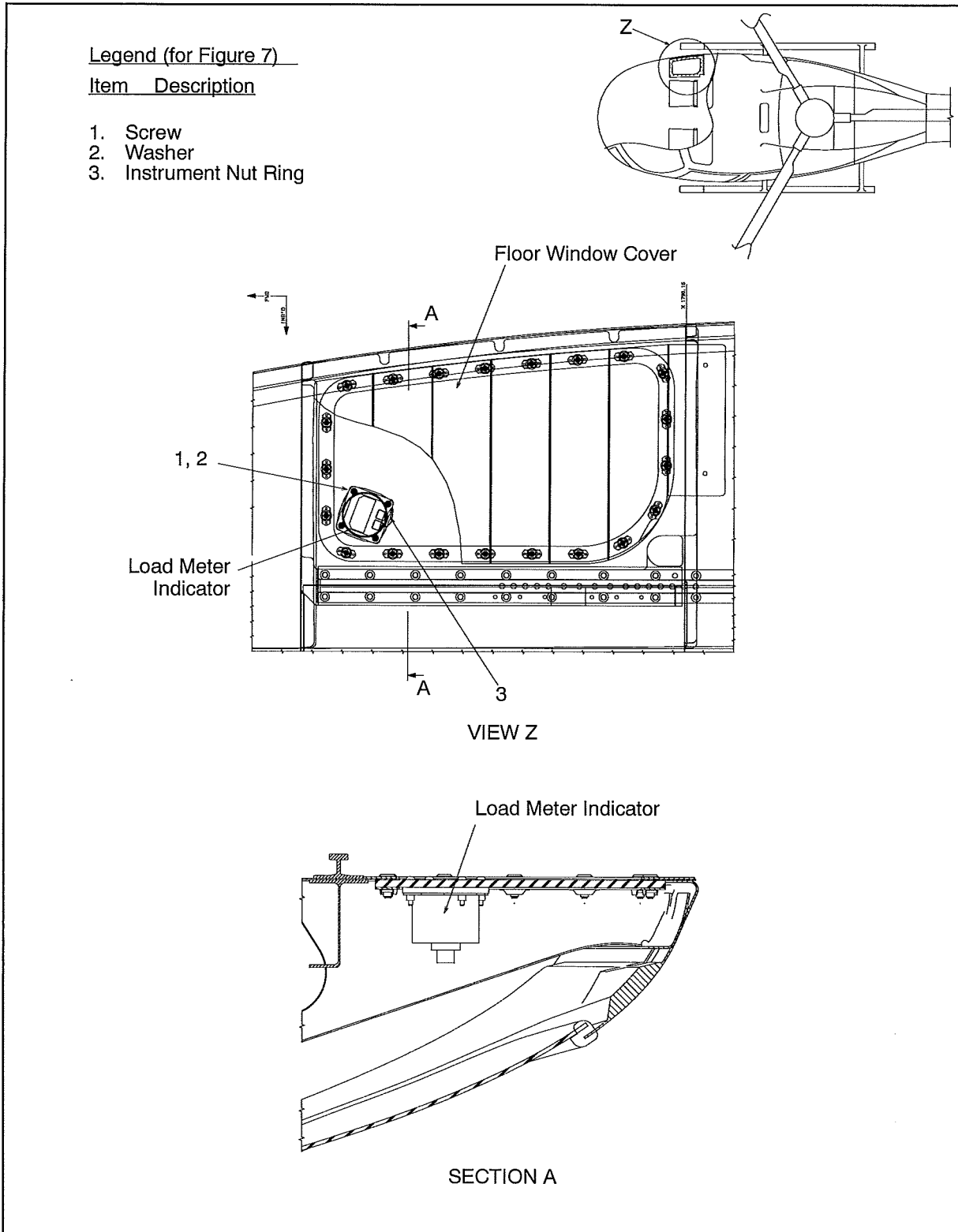

Figure 7 Load Meter relocation with Enlarged Vertical Reference Window Installation

Transport Canada Accepted

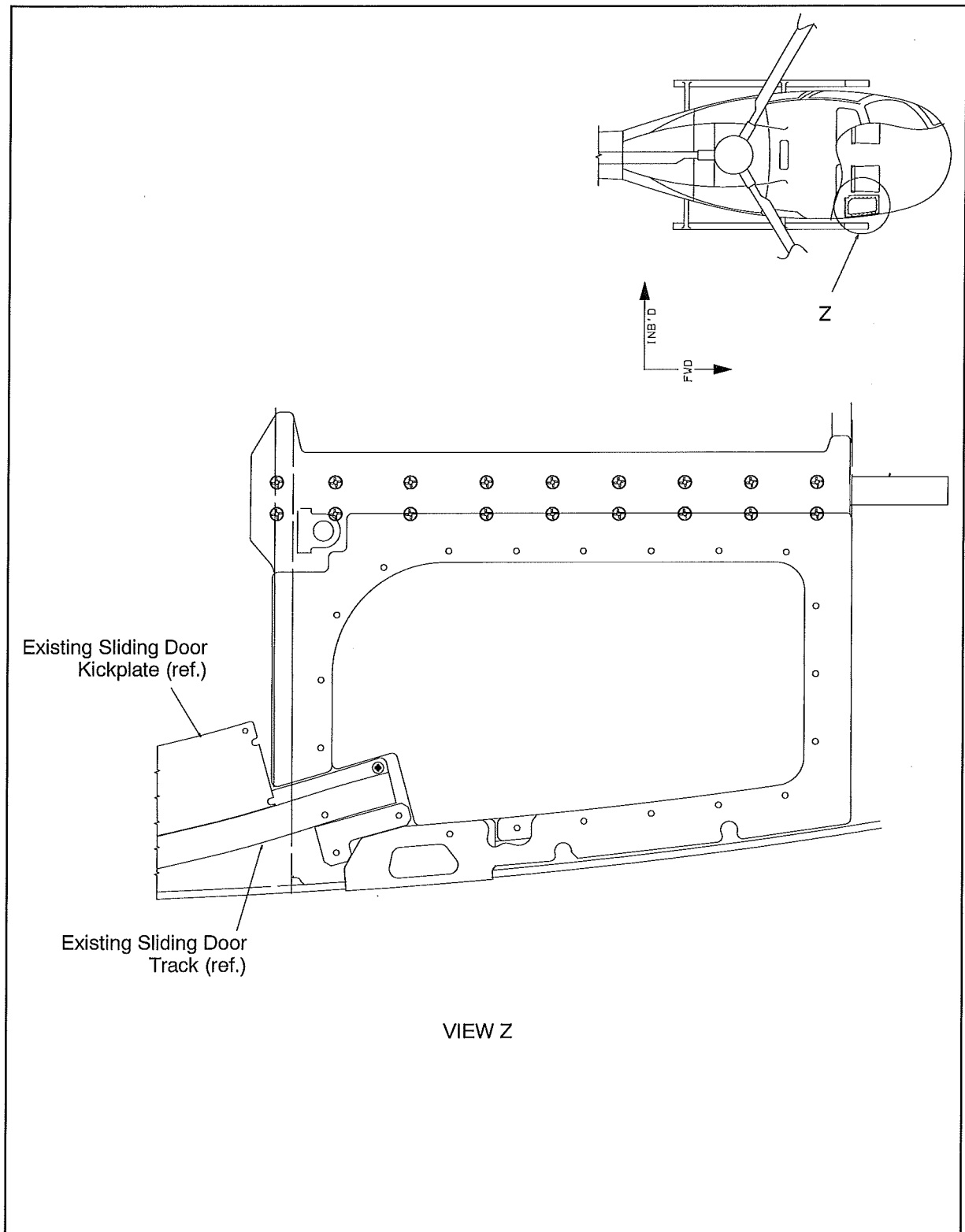

Figure 8 Enlarged Vertical Reference Window MOD with RHS Sliding Door (ESK-1295)

Transport Canada Accepted

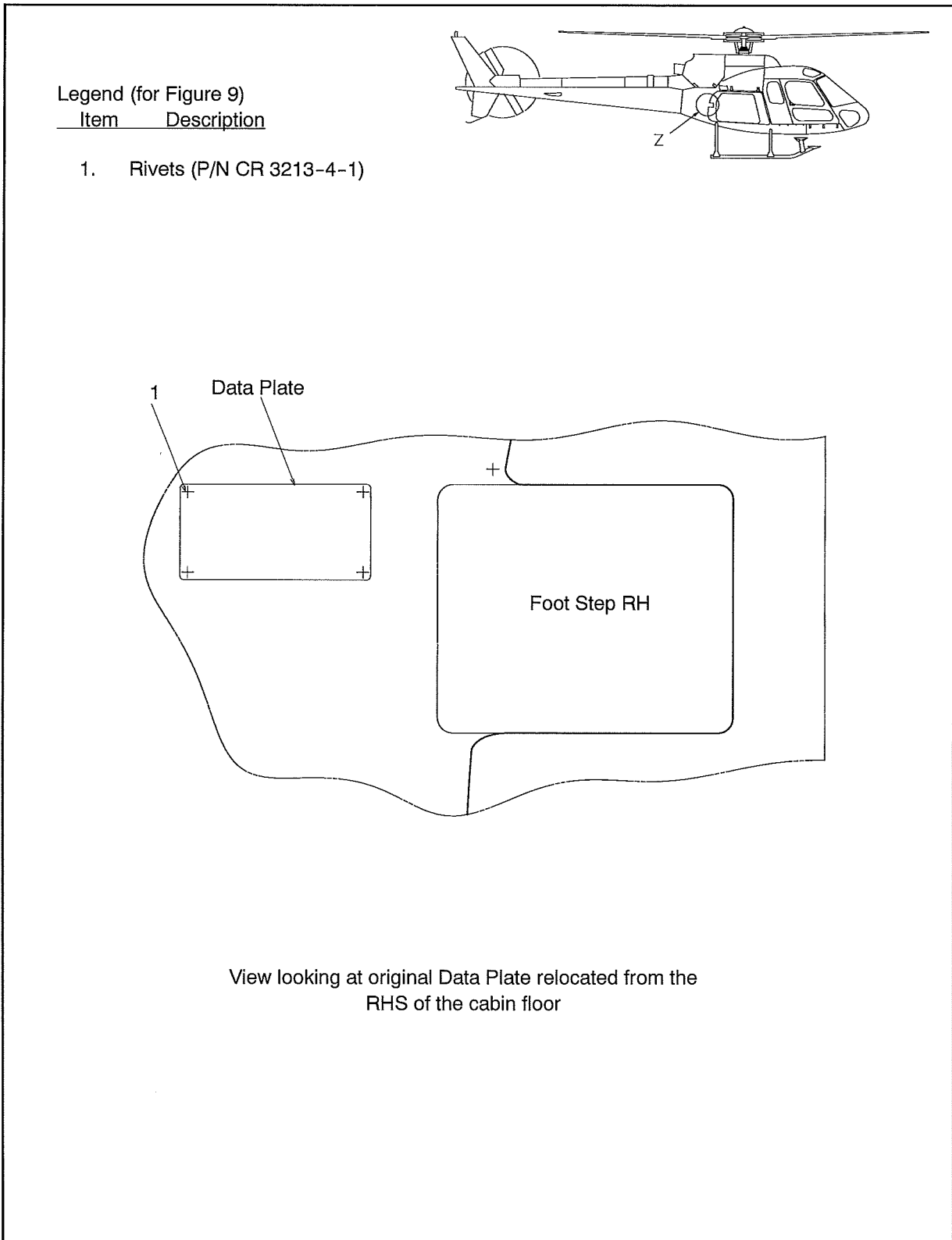

Figure 9 Fire Extinguisher Installation

Transport Canada Accepted

AIRBUS HELICOPTERS CANADA LIMITED

Figure 10 Forward Belly Panel MOD - Composite Lay-up

Transport Canada Accepted

AIRBUS HELICOPTERS CANADA LIMITED

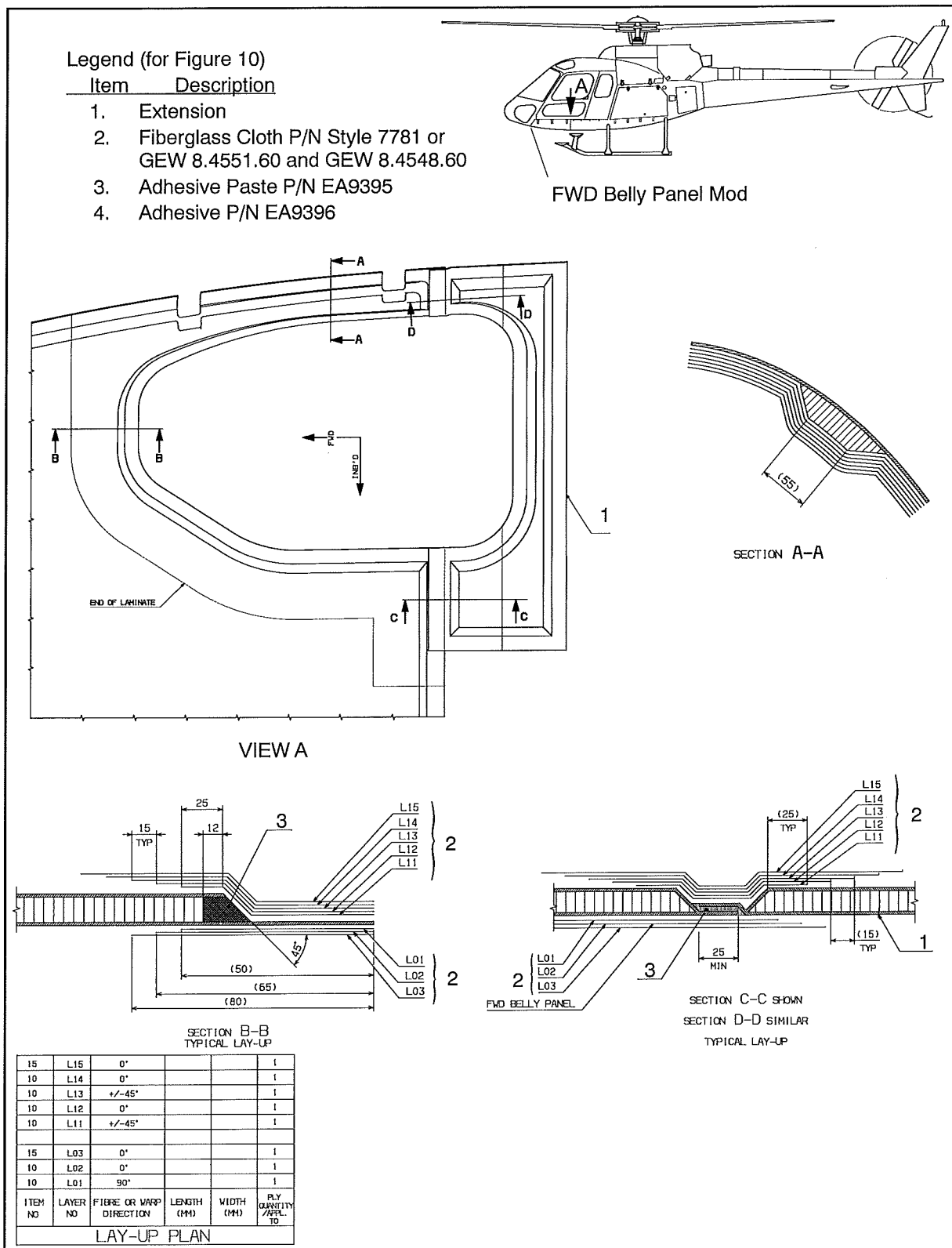
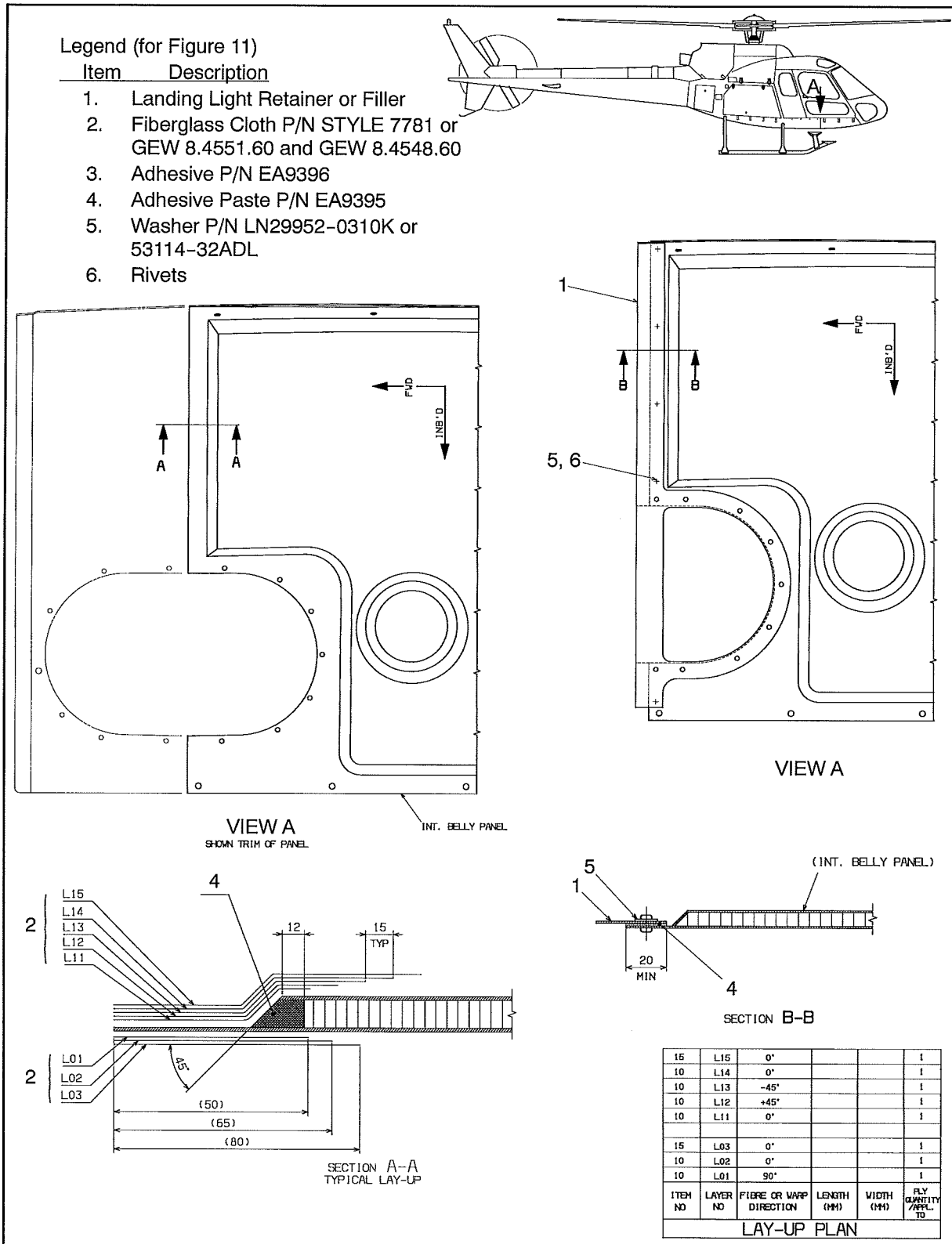

Figure 11 Intermediate Belly Panel MOD - Composite Lay-up

Transport Canada Accepted

AIRBUS HELICOPTERS CANADA LIMITED
C. REFERENCES

DOCUMENT	DOCUMENT TITLE
AMM	Aircraft Maintenance Manual
AMS 07 3180	Avis de Modification Serie 07 3180 Option of Modification Series 07 3180
IP-ECL-116	Installation Procedure, Enlarged Vertical Reference Window
MET	AS 350 / AS 355 Maintenance Manual
MFI.MCS	Fault Isolation and Wiring Diagram Manual
MTC	Standard Practices Manual

D. ABBREVIATIONS & DEFINITIONS

ABBREVIATION	DEFINITION
AHCA	Airbus Helicopters Canada Limited
A	Amp
Acc'd	Accepted
ANN	Annunciator
App'd	Approved
A/W	Airworthiness
CAR	Canadian Aviation Regulations
CTRL	Control
D	Days
DAPM	Design Approval Procedure Manual
FAA	Federal Aviation Administration
FH	Flight Hours
FWD	Forward
hrs	hours
IND	Indicator
M	Months
Misc.	Miscellaneous
MOD	Modification
P/N	Part Number
RHS	Right-Hand Side
ref.	reference
STC	Supplemental Type Certificate
TCCA	Transport Canada Civil Aviation
TQ ANN	Torque Annunciator
VEMD	Vehicle and Engine Multifunction Display
VFR	Visual Flight Rules

E. UNITS OF MEASUREMENT

ABBREVIATION / SYMBOL	UNIT OF MEASUREMENT
in	inch
kg	kilogram
lb	pound
m	meter

Transport Canada Accepted



**INSTRUCTIONS FOR CONTINUED
AIRWORTHINESS
ENLARGED VERTICAL REFERENCE
WINDOW INSTALLATION
AS 350 / AS 355**

AIRBUS HELICOPTERS CANADA LIMITED

2. AIRWORTHINESS LIMITATIONS

The Airworthiness Limitations section is approved by the Minister and specifies maintenance required by any applicable airworthiness or operating rule unless an alternative program has been approved by the Minister. ■

The Airworthiness Limitations section is FAA approved and specifies inspections and other maintenance required under §§43.16 and 91.403 of Federal Aviation Regulations unless an alternative program has been FAA approved. ■

The airworthiness limitations section is approved and variations must also be approved.

No airworthiness limitations associated with this installation.

Transport Canada - Approved

AIRBUS HELICOPTERS CANADA LIMITED
3. CONTROL AND OPERATION

Apart from the following, control and operation of the aircraft remains unchanged.

The floor mounted torque meter is selected with a toggle switch located on the Instrument Panel which when selected activates an indicator light which remains illuminated while the floor mounted torque meter is in use.

4. INSPECTION SCHEDULE AND MAINTENANCE ACTION

NOTE: Use torque per MTC, Chapter 20.02.05.404, unless otherwise specified.

4.1. INSPECTION SCHEDULE
4.1.1. Before the first flight of each day:

ITEM	INSPECTION OR MAINTENANCE WORK	CORRECTIVE ACTION
A	- If operating with the floor mounted torque meter, apply power to 31 Alpha Standard Fuse Panel (Master/Battery switch to ON) and: a. Push Press to Test FLOOR TORQUE INDICATOR annunciator	a. If light fails to illuminate, refer to Section 6, Troubleshooting.

Table 1 Inspection Schedule and Maintenance Action
 Before the first flight of each day

NOTE: The "Before the first flight of each day" task can be carried out by a suitably trained pilot or maintenance personnel.

4.1.2. Pre-Flight Check:

ITEM	INSPECTION OR MAINTENANCE WORK	CORRECTIVE ACTION
A	- Check floor window, item 6, and belly panel window, item 8, in Figure 2, for: a. cleanliness b. general condition	a. Clean windows with commercially available plastic cleaner. b. Contact AHCA for replacement parts.

Table 2 Inspection Schedule and Maintenance Action
 Pre-Flight Check

NOTE: The "Pre-Flight Check" task can be carried out by a suitably trained pilot or maintenance personnel.

Transport Canada Accepted

AIRBUS HELICOPTERS CANADA LIMITED
4. INSPECTION SCHEDULE AND MAINTENANCE ACTION
4.1. INSPECTION SCHEDULE

4.1.3. Every 150 FH or 12 M (Margin: 15 FH or 36 D) to coincide with the 150 FH or 12 M helicopter inspection, whichever occurs first:

ITEM	INSPECTION OR MAINTENANCE WORK	CORRECTIVE ACTION
A	- Inspect velcro, item 9 on Floor Window Cover, item 1, in Figure 2, for: a. wear (tears, areas have become worn)	a. Wear is not permitted, if wear is evident, replace Velcro in accordance with MTC, Chapter 20.03.04.406.
B	- Inspect floor window, item 6 and belly panel window, item 8, in Figure 2, for: a. cracking or crazing	a. No cracking or crazing is allowed. If cracking or crazing is found replace window. Contact AHCA for replacement parts.
C	- Visually inspect window channel seal, item 7, between FWD belly panel, item 10, and belly panel window, item 8, in Figure 2, for: a. cuts and cracking	a. If cuts or cracks are evident replace window seal in accordance with MET, Chapter 52.00.00.401 for the AS 350/AS 355. For the AS 350 B2/B3 refer to AMM, Chapter 56-11-00, 4-3 .
D	- Visually inspect FWD belly panel Mod, item 1, and intermediate belly panel MOD, item 2, in Figure 3, for: a. general condition	a. Minor repairs may be accomplished in accordance with MTC, Chapter 20.03.07.101. For major repairs contact AHCA.

Table 3 Inspection Schedule and Maintenance Action
 Every 150 FH or 12 M, to coincide with the 150 FH or 12 M helicopter inspection, whichever occurs first
 (continued on following page)

Transport Canada Accepted

AIRBUS HELICOPTERS CANADA LIMITED
4. INSPECTION SCHEDULE AND MAINTENANCE ACTION
4.1. INSPECTION SCHEDULE (continued)

4.1.3. Every 150 FH or 12 M (Margin: 15 FH or 36 D) to coincide with the 150 FH or 12 M helicopter inspection, whichever occurs first:

ITEM	INSPECTION OR MAINTENANCE WORK	CORRECTIVE ACTION
E	- Visually inspect FWD belly panel Mod, item 1, and intermediate belly panel MOD, item 2, in Figure 3, for: a. delamination or irregularity	a. For the AS 355 determine extent of the damage in accordance with MTC, Chapter 20-03-06-601, Section B (1) and (2). Repair all models in accordance with MTC, Chapters 20-03-06-401, Section 401, C and 20.03.07.101. (Refer to Figures 9 & 10 for Composite Lay up).
F	- Check fire extinguisher installation attachment hardware, items 1, 2 and 3, in Figure 4 for: a. security	a. Re-tighten as required.
G	- Visually inspect data plate shown in Figure 9 for: a. security b. corrosion	a. Secure as required. b. If corrosion is found, clean in accordance with MTC, Chapter 20.04.03.401.
H	- Check placards and markings, (refer to Section 10) for: a. legibility b. secure mounting	a. If placards and markings have become illegible, contact AHCA for replacement parts (refer to IP-ECL-116). NOTE: Data Plate (Figure 13) will not be replaced. b. Secure or reattach placards and markings as required.

Table 3 Inspection Schedule and Maintenance Action
 Every 150 FH or 12 M, to coincide with the 150 FH or 12 M helicopter inspection, whichever occurs first

Transport Canada Accepted

AIRBUS HELICOPTERS CANADA LIMITED
5. OVERHAUL REQUIREMENTS

Contact AHCA for replacement parts. No overhaul information required for this installation.

For replacement components:

Airbus Helicopters Canada Limited
 1100 Gilmore Road, P.O. Box 250
 Fort Erie, Ontario L2A 5M9 Canada
 Telephone: (905) 871-7772
 Telefax: (905) 871-3599

Website: www.airbushelicopters.ca

6. TROUBLESHOOTING

For electrical system troubleshooting for aircraft with the optional Floor Mounted Torque Indicator Option, refer to Figure 12 Wiring Diagram shown with Floor-Mounted Torque Indicator Option - to be used with Control Panel in Figure 15 (original diagram) or Figure 13 Wiring Diagram shown with Floor-Mounted Torque Indicator Option - to be used with Control Panel in Figure 16.

ITEM	TROUBLE / SYMPTOM	PROBABLE CAUSE	CORRECTIVE ACTION
1	Indicator light on the Instrument Panel does not illuminate during Daily Preflight Inspection	Bulb burnt out. Break or short in activator circuits	Replace bulb, P/N MS25041-3 Perform circuit continuity check and repair/replace wiring as applicable in accordance with AC43.13-1B, Chapter 11, Section 1
2	Indicator light illuminates during operation when floor mounted torque indicator is not in use	Short in annunciator circuit.	Perform circuit continuity check and repair/replace wiring as applicable in accordance with AC43.13-1B, Chapter 11, Section 1

Table 4 Troubleshooting Guide

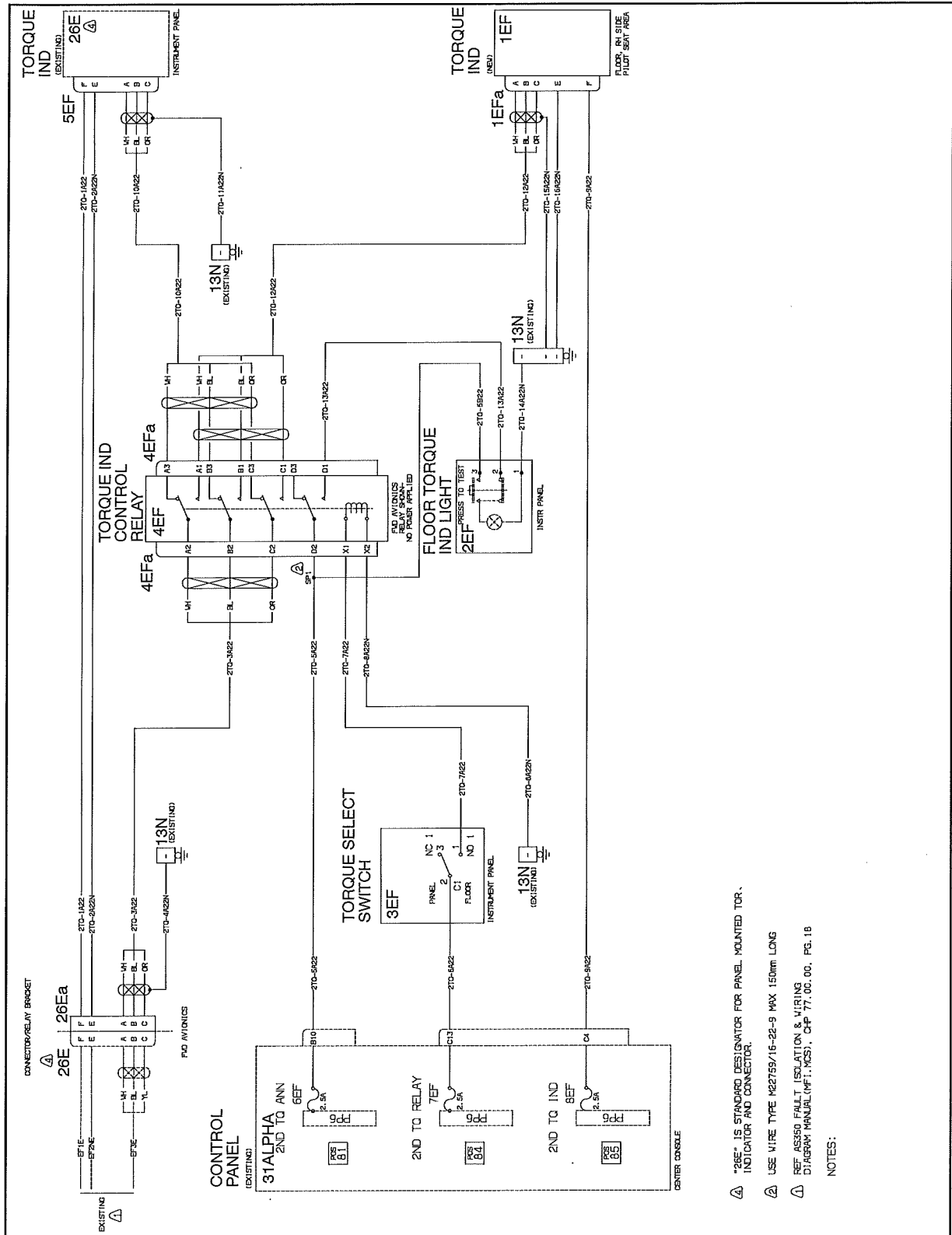

Figure 12 Wiring Diagram shown with Floor-Mounted Torque Indicator Option - to be used with Control Panel in Figure 15 (original diagram)

Transport Canada Accepted

AIRBUS HELICOPTERS CANADA LIMITED

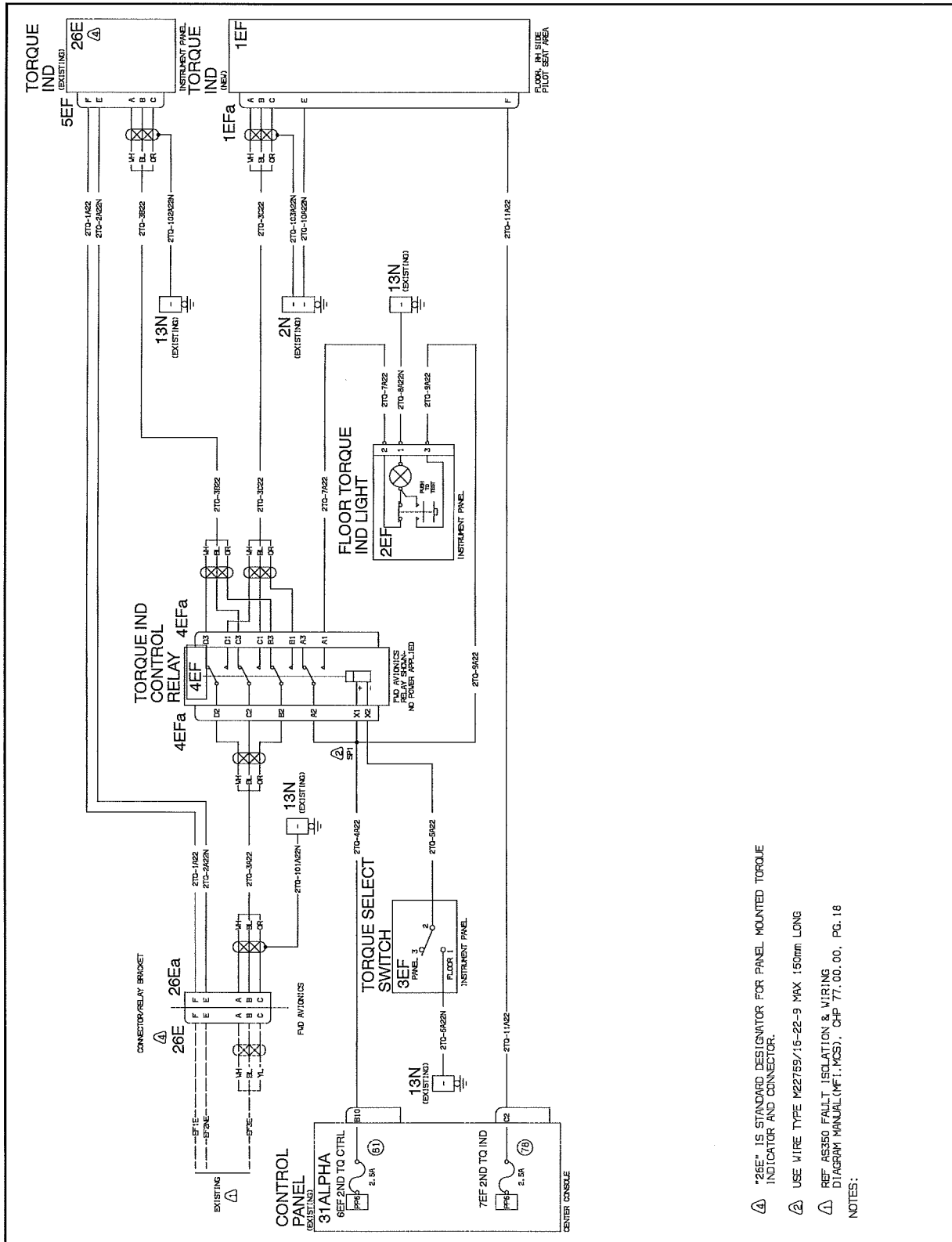

Figure 13 Wiring Diagram shown with Floor-Mounted Torque Indicator Option - to be used with Control Panel in Figure 16

- Ⓐ *26E* IS STANDARD DESIGNATOR FOR PANEL MOUNTED TORQUE INDICATOR AND CONNECTOR.
 - Ⓐ USE WIRE TYPE M22759/16-22-9 MAX 150mm LONG
 - Ⓐ REF AS350 FAULT ISOLATION & WIRING DIAGRAM MANUAL (F.I.M.S.), CHP 77.00.00, PG. 18
- NOTES:

Transport Canada Accepted

AIRBUS HELICOPTERS CANADA LIMITED**7. SPECIAL TOOLING**

No special test equipment or tools are required. Standard tools are adequate.

8. REMOVAL AND REPLACEMENT**PRELIMINARIES**

- A. If modifying an AS 350 (excluding AS 350 B2/B3):
 - Read and comply with Electrical Power, General Instructions AS 350 MET, Chapter 24.00.00.301 and disconnect the external power unit and battery.
- B. If modifying an AS 350 B2/B3:
 - Read and comply with General Safety Instructions - Electrical Power Supply System, AS 350 B2, B3, AMM, Chapter 24-00-00, 3-1).
 - Read and comply with Electrical Power Supply on the Ground, AS 350 B2, B3, AMM, Chapter 24-00-00, 2-1 A & B and disconnect the external power unit and battery.
- C. If modifying an AS 355:
 - Read and comply with Electrical Power, General Instructions AS 355 MET, Chapter 24.00.00.301 and disconnect the external power unit and battery
- D. Open any circuit breakers associated with the left Side Pilot Configuration.
- E. Remove forward belly panel MOD (1) and store for reinstallation. Refer to Figure 2. Refer to Removal, AS 350 / AS 355 MET Chapter 53.00.00.405. For the AS 350 B2/B3, refer to Removal - Lower Fairing - AMM, Chapter 53-51-00, 4-2.

A. REMOVAL

- 1) FLOOR WINDOW (Refer to Figure 2)
 - a) Remove screws (2) (2 places), and washers (3) (2 places) and remove floor window cover (1).
 - b) Remove countersunk screws (4) (21 places), and remove floor window (6), and floor window backing plate (5).
- 2) BELLY PANEL WINDOW (Refer to Figure 2)
 - a) Remove window channel seal (7) from belly panel window (8) in accordance with the AS 350 / AS 355 MET, Chapter 52.00.00.401. For AS 350 B2/B3 refer to AMM, Chapter 56-11-00, 4-3.
 - b) Remove belly panel window (8).
- 3) OPTIONAL FLOOR MOUNTED TORQUE METER INSTALLATION
(if installed, AS 350 B2 without VEMD only, refer to Figure 5 if aircraft utilizes original installation or Figure 6 if aircraft has reinforced floor).
 - a) Disconnect wiring harness (2) from torque meter (1).
 - b) Disconnect clamp (6) from support bracket (9) by removing screw (3), washer (4), and nut (5).
 - c) Remove screws (7) (4 places) from mounting bracket (8) and remove torque meter (1).

Transport Canada Accepted

AIRBUS HELICOPTERS CANADA LIMITED**B. REPLACEMENT**

NOTE Use torque per MTC, Chapter 20.02.05.404, unless otherwise specified.

- 1) FLOOR MOUNTED TORQUE METER INSTALLATION
(AS 350 B2 without VEMD only, refer to Figure 5 if aircraft utilizes original installation or Figure 6 if aircraft utilizes alternative installation).
 - a) Position torque meter (1) on mounting bracket (8) and secure using screws (7) (4 places).
 - b) Secure clamp (6) around torque meter (1) to support bracket (9) using screw (3), washer (4), and nut (5).
 - c) Reconnect wiring harness connector (2) to torque meter (1).
- 2) BELLY PANEL WINDOW (Refer to Figure 2)
 - a) Reinstall belly panel window (8) with window channel seal (7) in accordance with the AS 350 / AS 355 MET, Chapter 52.00.00.401. For AS 350 B2/B3 refer to AMM, Chapter 56-11-00, 4-3.
- 3) FLOOR WINDOW (Refer to Figure 2)
 - a) Position floor window (6), and floor window backing plate (5) and secure using countersunk screws (4) (21 places).
 - b) Position floor window cover (1) and secure to floor using screws (2) (2 places), and washers (3) (2 places).
- 4) Close all areas opened for service in the PRELIMINARIES paragraph of this section.
- 5) Reinstall the forward belly panel mod (1). Refer to Figure 2.
For the AS 350/AS 355, refer to Installation MET Chapter 53.00.00.405.
For the AS 350 B2/B3, refer to Installation - Lower Fairing - AMM, Chapter 53-51-00, 4-2.
- 6) For AS 350 / AS 355 (excluding AS 350 B2/B3):
 - Apply external power unit and battery and perform functional test in accordance with AS 350/AS 355 MET, Chapter 24.30.00.501.
- 7) For AS 350 B2/B3:
 - Before energizing the aircraft power supply system, read and comply with safety instructions, in accordance with General Safety Instruction - Electrical Power Supply System, AS 350 B2/B3, AMM, Chapter 24-00-00, 3-1.
 - Reconnect the external power unit and battery, and perform functional test - DC Power Supply System in accordance with AS 350 B2/B3 AMM, Chapter 24-30-00-5-1 A, B or C depending on MOD.
- 8) Close all areas opened for service in the PRELIMINARIES paragraph of this section.
- 9) Perform operational check of all systems that were serviced in accordance with the AS 350 MET or AS 350 (B2/B3) AMM procedures and the system's installation/operation manual.

Transport Canada Accepted

AIRBUS HELICOPTERS CANADA LIMITED
9. WEIGHT AND BALANCE DATA
A. Removed Items

DESCRIPTION	WEIGHT		ARM		MOMENT	
	kg	lbs	m	in	kg m	lb in
Floor Cut-out	- 0.27	- 0.6	1.55	61.0	- 0.42	- 36.6
Belly Panel Cut-out	- 0.59	- 1.3	1.55	61.0	- 0.91	- 79.3
Basic aircraft Fire Extinguisher Assembly	- 2.18	- 4.8	1.67	65.7	- 3.64	- 315.4
Total	- 3.04	- 6.7	1.64	64.4	- 4.97	- 431.3

B. Added Items - without Floor-Mounted Torque Indicator Option

DESCRIPTION	WEIGHT		ARM		MOMENT	
	kg	lbs	m	in	kg m	lb in
Floor Window	1.18	2.6	1.55	61.0	1.83	158.6
Floor Window Seal	1.40	3.1	1.55	61.0	2.17	189.1
Floor Window Backing Plate	0.15	0.3	1.55	61.0	0.23	18.3
Floor Window Cover	0.35	0.8	1.55	61.0	0.54	48.8
Velcro Loop	0.02	0.0	1.55	61.0	0.03	0.0
Belly Panel Window and seal	1.35	3.0	1.55	61.0	2.09	183.0
Floor Window Inst. Hardware	0.70	1.5	1.55	61.0	1.09	91.5
Misc. (Rivets, Washers, Screws)	0.11	0.2	1.55	61.0	0.17	12.2
Total	5.26	11.5	1.55	61.0	8.15	701.5

C. Optional Item - with Floor-Mounted Torque Indicator Option

DESCRIPTION	WEIGHT		ARM		MOMENT	
	kg	lbs	m	in	kg m	lb in
Torque Indicator Installation	0.96	2.1	1.37	53.9	1.32	113.2
Total (add to "B")	0.96	2.1	1.37	53.9	1.32	113.2

Transport Canada Accepted

AIRBUS HELICOPTERS CANADA LIMITED
9. WEIGHT AND BALANCE DATA (continued)
D. Fire Extinguisher Relocation ESK-1436 (for AS 355 NP)

DESCRIPTION	WEIGHT		ARM		MOMENT	
	kg	lbs	m	in	kg m	lb in
Adapter Plate	0.22	0.5	1.92	75.6	0.42	37.8
Fire Extinguisher Assembly	2.18	4.8	1.92	75.6	4.19	362.9
Total (add to "B")	2.40	5.3	1.92	75.6	4.61	400.7

E. Fire Extinguisher Relocation 350-700014 (for aircraft with high back composite seat installation)

DESCRIPTION	WEIGHT		ARM		MOMENT	
	kg	lbs	m	in	kg m	lb in
Plate	0.08	0.2	1.92	75.6	0.15	15.1
Fire Extinguisher Assembly	2.18	4.8	1.92	75.6	4.19	362.9
Total (add to "B")	2.26	5.0	1.92	75.6	4.34	378.0

F. Fire Extinguisher Relocation 350-700184 (for aircraft with energy-absorbing type seat installation)

DESCRIPTION	WEIGHT		ARM		MOMENT	
	kg	lbs	m	in	kg m	lb in
Plate	0.08	0.2	1.79	70.5	0.14	14.1
Fire Extinguisher Assembly	2.18	4.8	1.79	70.5	3.90	338.4
Total (add to "B")	2.26	5.0	1.79	70.5	4.05	352.5

G. Fire Extinguisher Relocation 350-700194 (for aircraft with two-place front seat, STC SH93-72)

DESCRIPTION	WEIGHT		ARM		MOMENT	
	kg	lbs	m	in	kg m	lb in
Doubler Plate	0.13	0.3	1.89	74.4	0.25	22.3
Fire Extinguisher Assembly	2.18	4.8	1.89	74.4	4.12	357.1
Total (add to "B")	2.31	5.1	1.89	74.4	4.37	379.4

Transport Canada Accepted

AIRBUS HELICOPTERS CANADA LIMITED
9. WEIGHT AND BALANCE DATA (continued)
H. Additional Items - AS 350 POST MOD 07-3180

DESCRIPTION	WEIGHT		ARM		MOMENT	
	kg	lbs	m	in	kg m	lb in
Floor Doubler	0.45	1.0	1.55	61.0	0.70	61.0
Seat Track Shim	0.10	0.2	1.55	61.0	0.16	12.2
Seat Track Shim	0.03	0.1	1.55	61.0	0.05	6.1
Total (add to "B")	0.58	1.3	1.55	61.0	0.90	79.3

I. Additional Items - AS 350 POST MOD 07-3180 with RHS Sliding Door

DESCRIPTION	WEIGHT		ARM		MOMENT	
	kg	lbs	m	in	kg m	lb in
Floor Doubler	0.97	2.1	1.55	61.0	1.50	128.1
Shim	0.20	0.4	1.55	61.0	0.31	24.4
Stiffener	0.22	0.5	1.55	61.0	0.33	30.5
Total (add to "B")	1.39	3.0	1.55	61.0	2.15	183.0

J. Additional Items - AS 350 PRE MOD 07-3180 and AS 355

DESCRIPTION	WEIGHT		ARM		MOMENT	
	kg	lbs	m	in	kg m	lb in
Floor Doubler	0.32	0.7	1.55	61.0	0.50	42.7
Window Stiffener	0.08	0.2	1.55	61.0	0.12	12.2
Floor Window Clip	0.06	0.1	1.55	61.0	0.09	6.1
Total (add to "B")	0.46	1.0	1.55	61.0	0.71	61.0

K. Additional Items - AS 350 PRE MOD 07-3180 with RHS Sliding Door

DESCRIPTION	WEIGHT		ARM		MOMENT	
	kg	lbs	m	in	kg m	lb in
Floor Doubler	0.64	1.4	1.55	61.0	1.00	85.4
Shim	0.20	0.4	1.55	61.0	0.31	24.4
Stiffener	0.22	0.5	1.55	61.0	0.33	30.5
Total (add to "B")	1.06	2.3	1.55	61.0	1.64	140.3

Transport Canada Accepted

AIRBUS HELICOPTERS CANADA LIMITED

10. PLACARDS AND MARKINGS

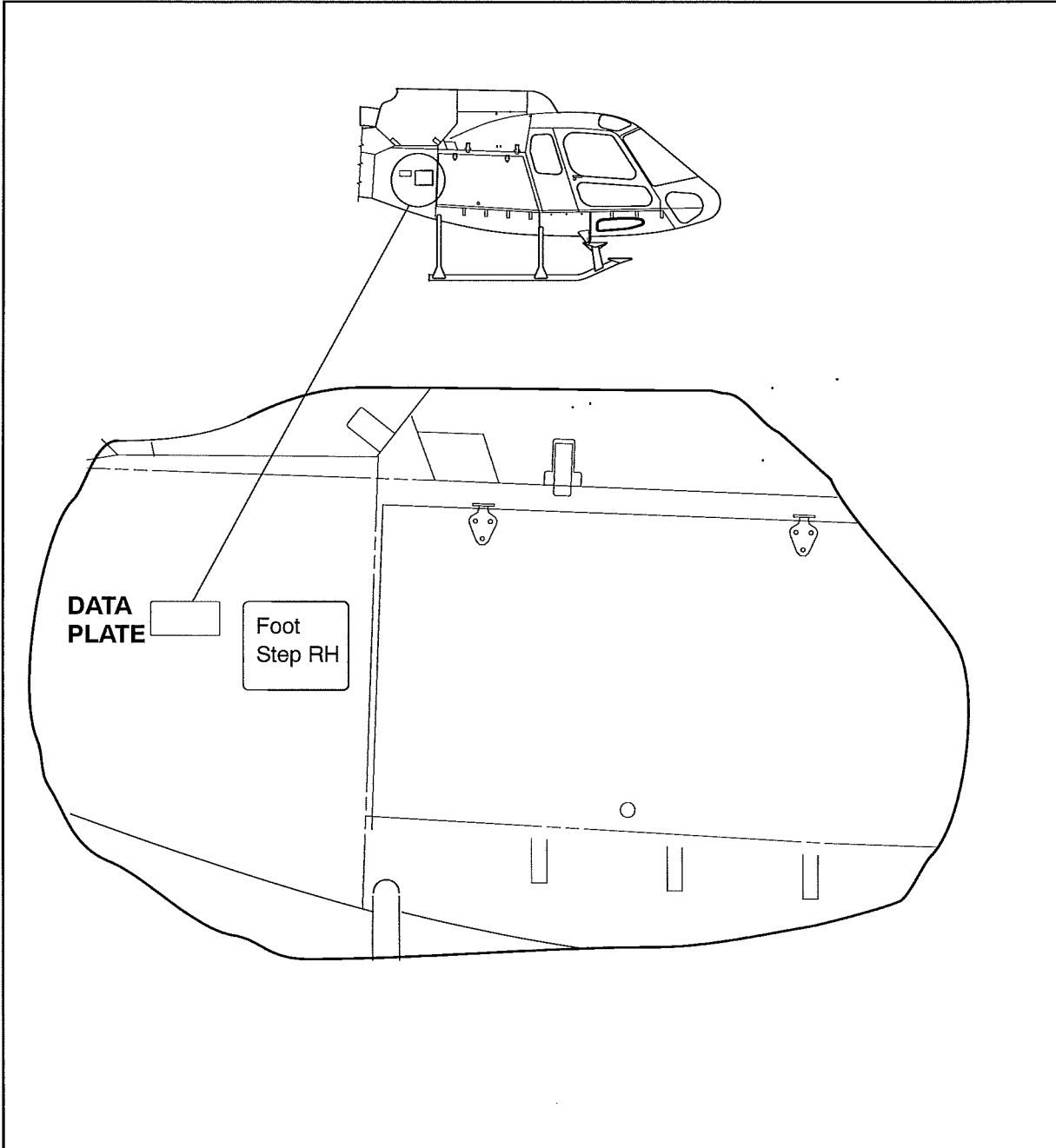

Figure 14 Data Plate Relocation

Transport Canada Accepted

AIRBUS HELICOPTERS CANADA LIMITED

10. PLACARDS AND MARKINGS (continued)

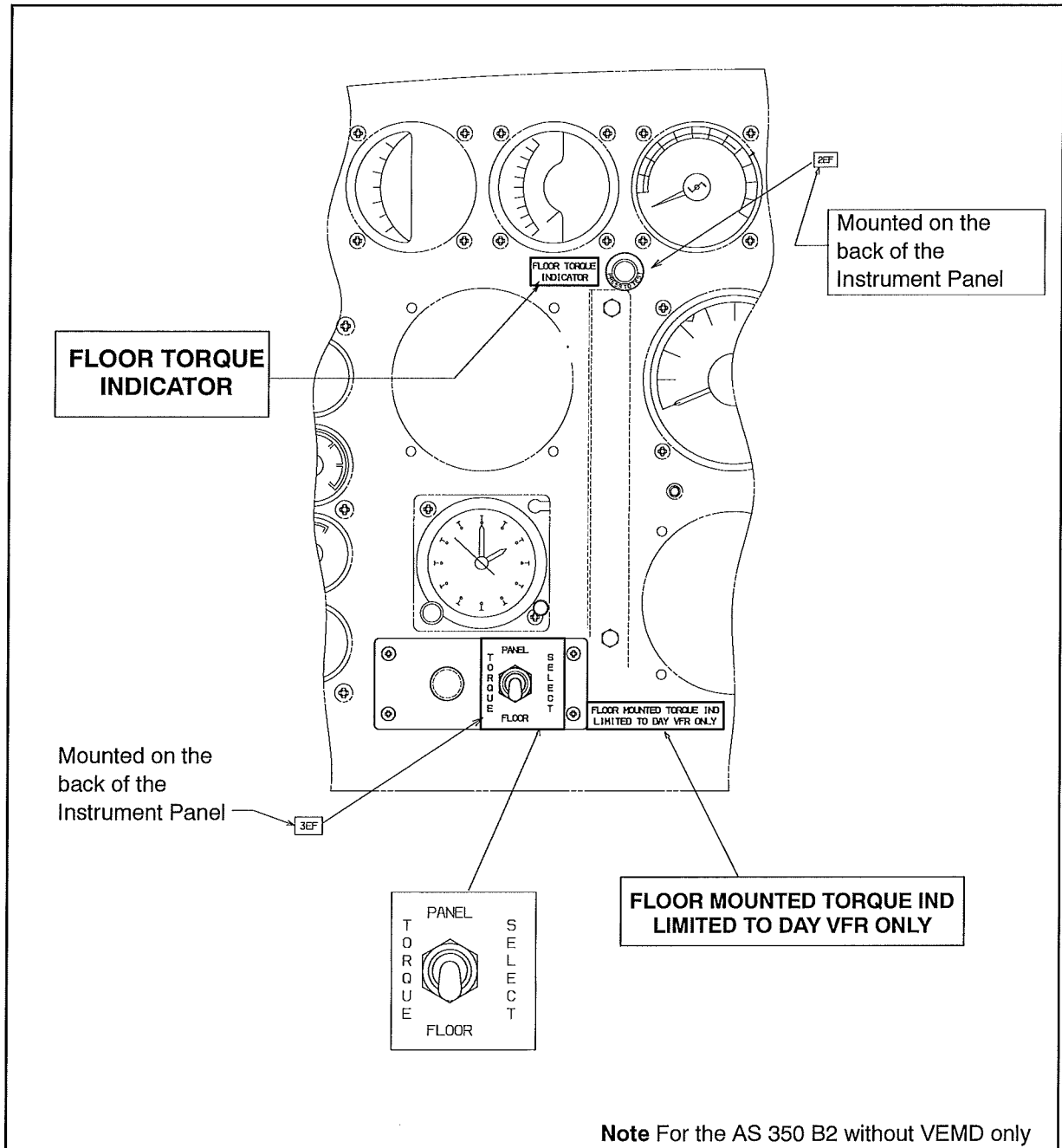

Figure 15 Placards on Instrument Panel with Floor-Mounted Torque Indicator Option

Transport Canada Accepted

AIRBUS HELICOPTERS CANADA LIMITED

10. PLACARDS AND MARKINGS (continued)

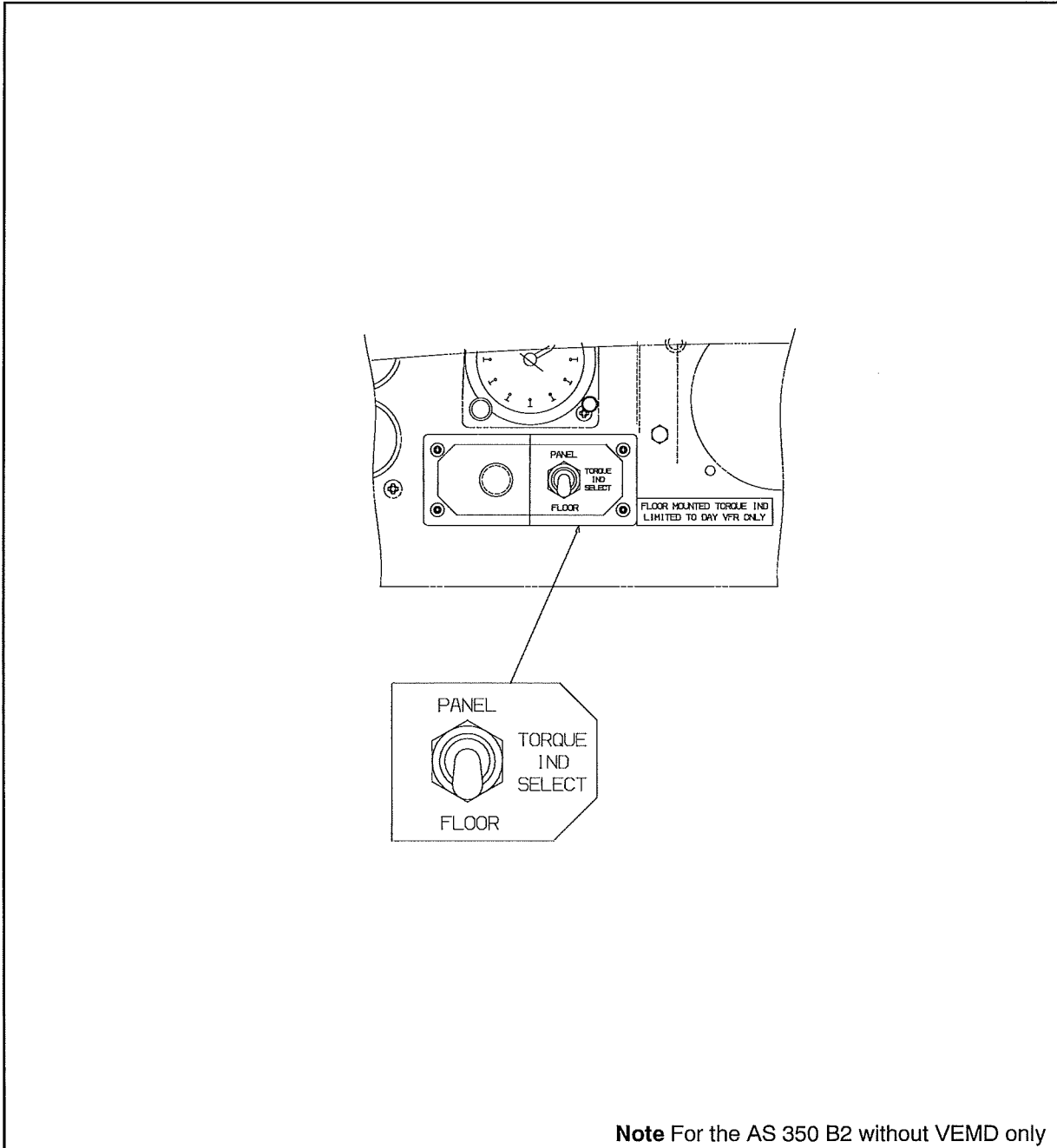

Figure 16 Placard on Instrument Panel with Floor-Mounted Torque Indicator Option

Transport Canada Accepted

AIRBUS HELICOPTERS CANADA LIMITED

10. **PLACARDS AND MARKINGS** (continued)

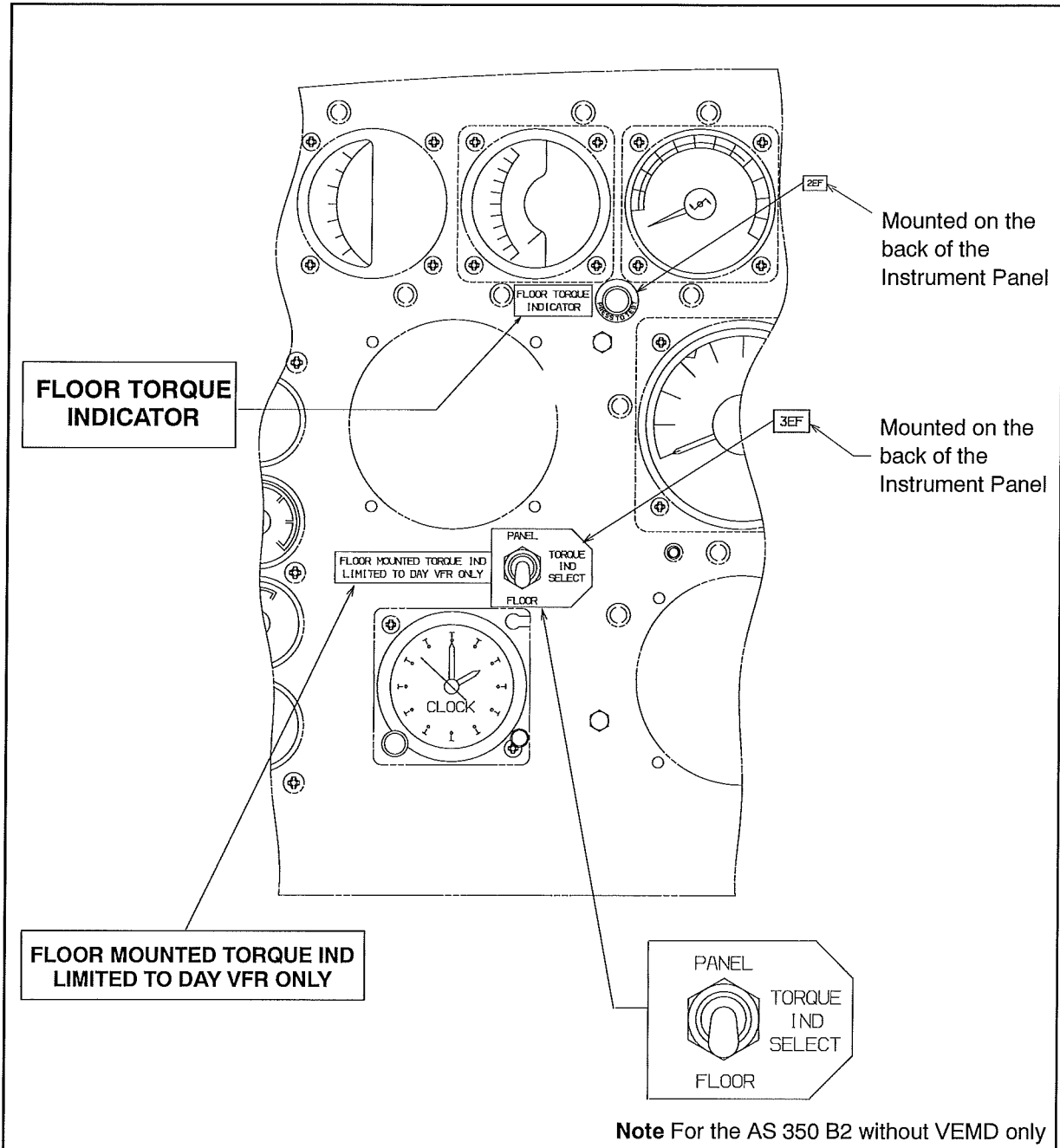

Figure 17 Placards on Instrument Panel alternate location with Floor-Mounted Torque Indicator Option

Transport Canada Accepted

AIRBUS HELICOPTERS CANADA LIMITED

10. PLACARDS AND MARKINGS (continued)

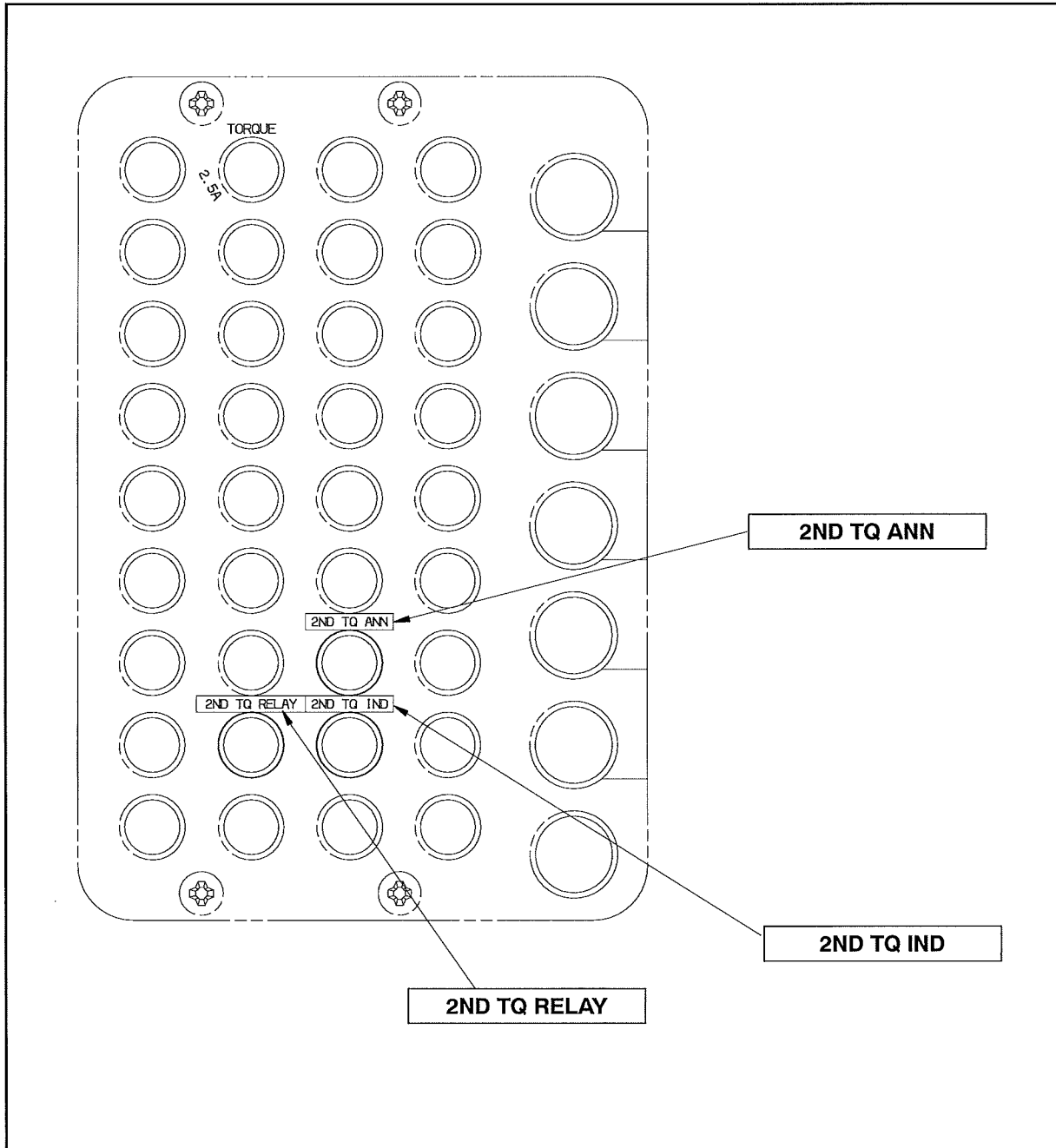

Figure 18 Placards on fuse panel with Floor-Mounted Torque Indicator Option

Transport Canada Accepted

AIRBUS HELICOPTERS CANADA LIMITED

 10. **PLACARDS AND MARKINGS** (continued)

Figure 19 Placards on alternative fuse panel with Floor-Mounted Torque Indicator Option

Transport Canada Accepted

AIRBUS HELICOPTERS CANADA LIMITED

10. **PLACARDS AND MARKINGS** (continued)

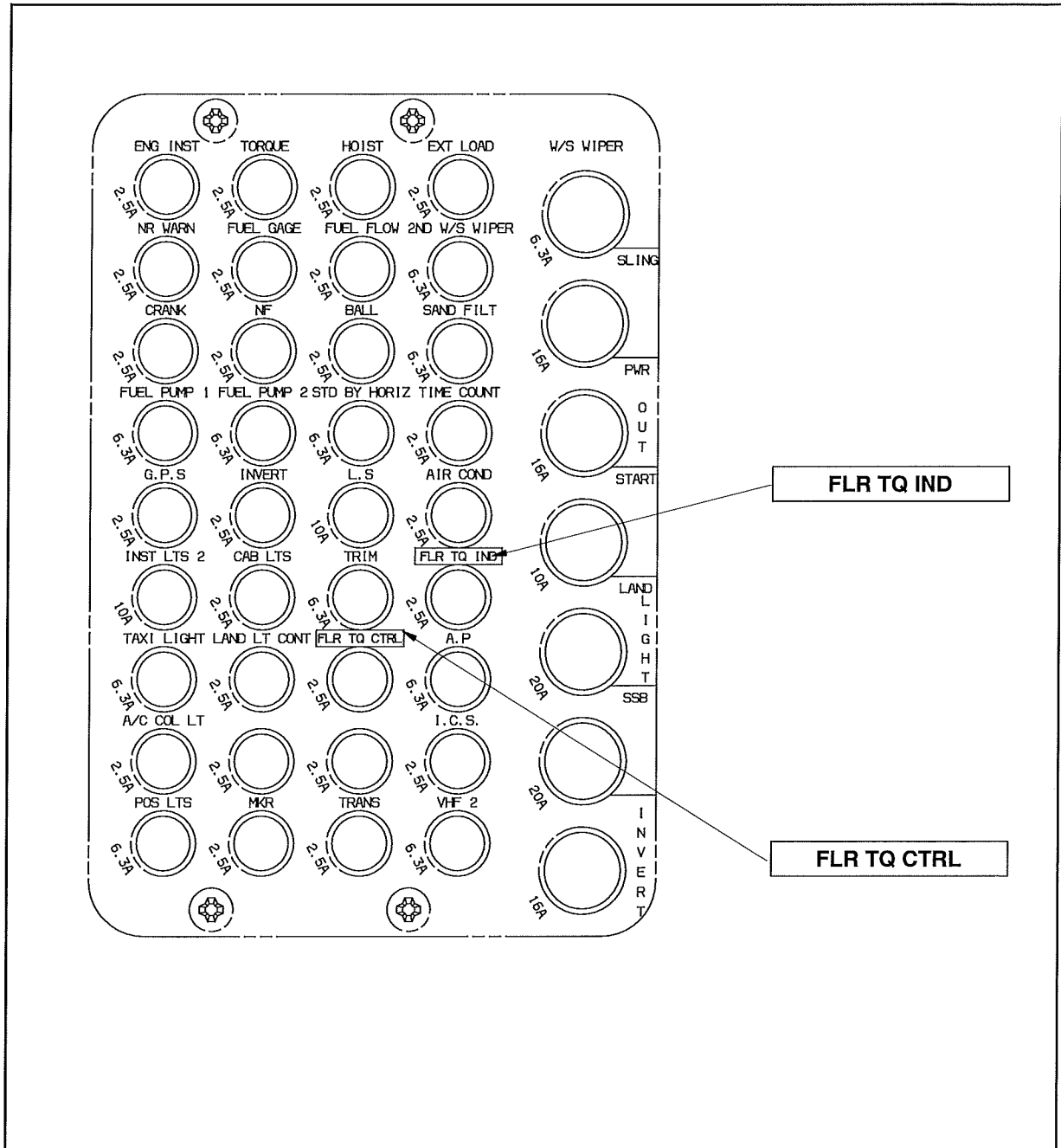
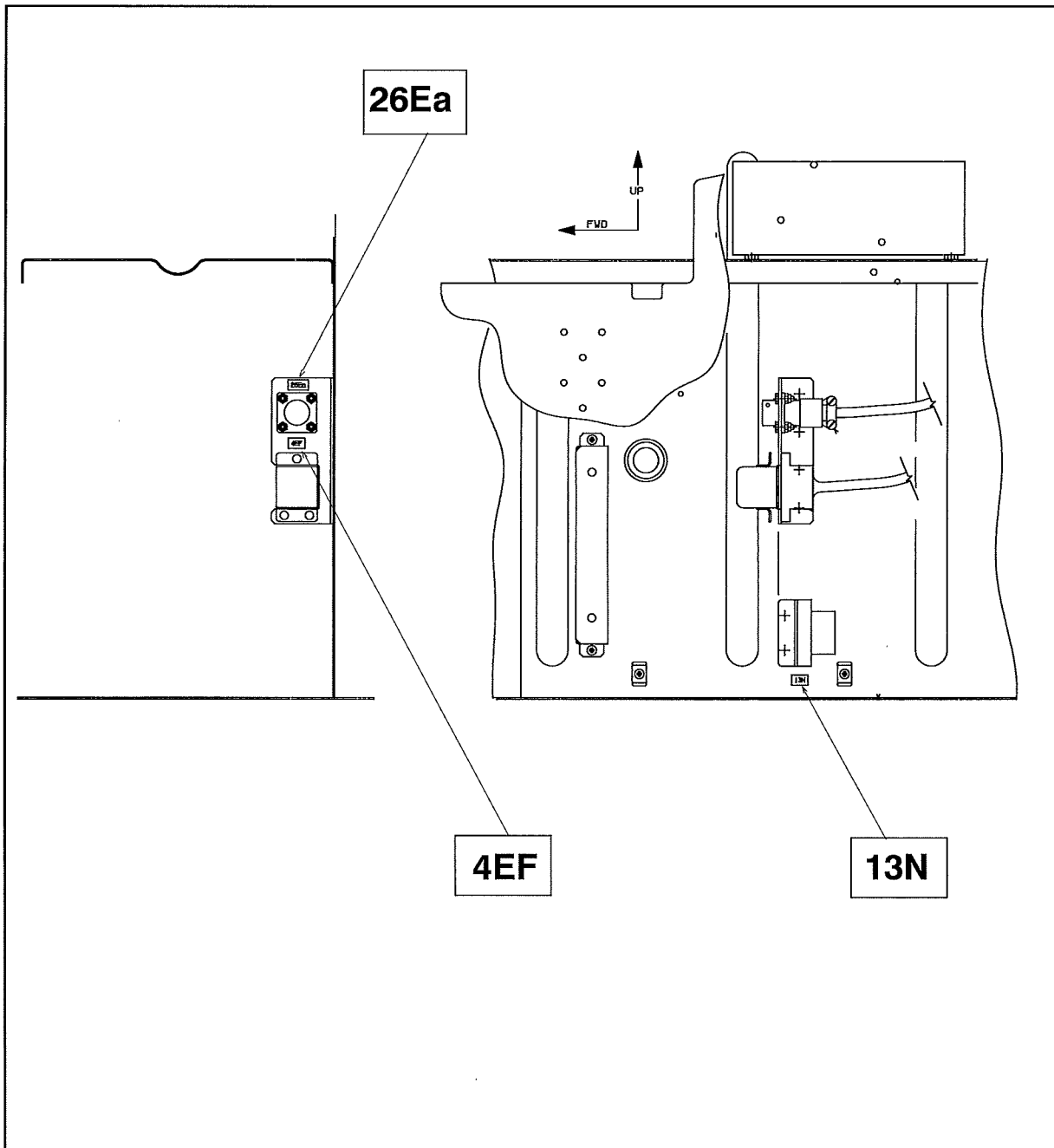

Figure 20 Placards FWD of center console in Nose Bay, LHS -
with Floor-Mounted Torque Indicator Option

Transport Canada Accepted

AIRBUS HELICOPTERS CANADA LIMITED

10. PLACARDS AND MARKINGS

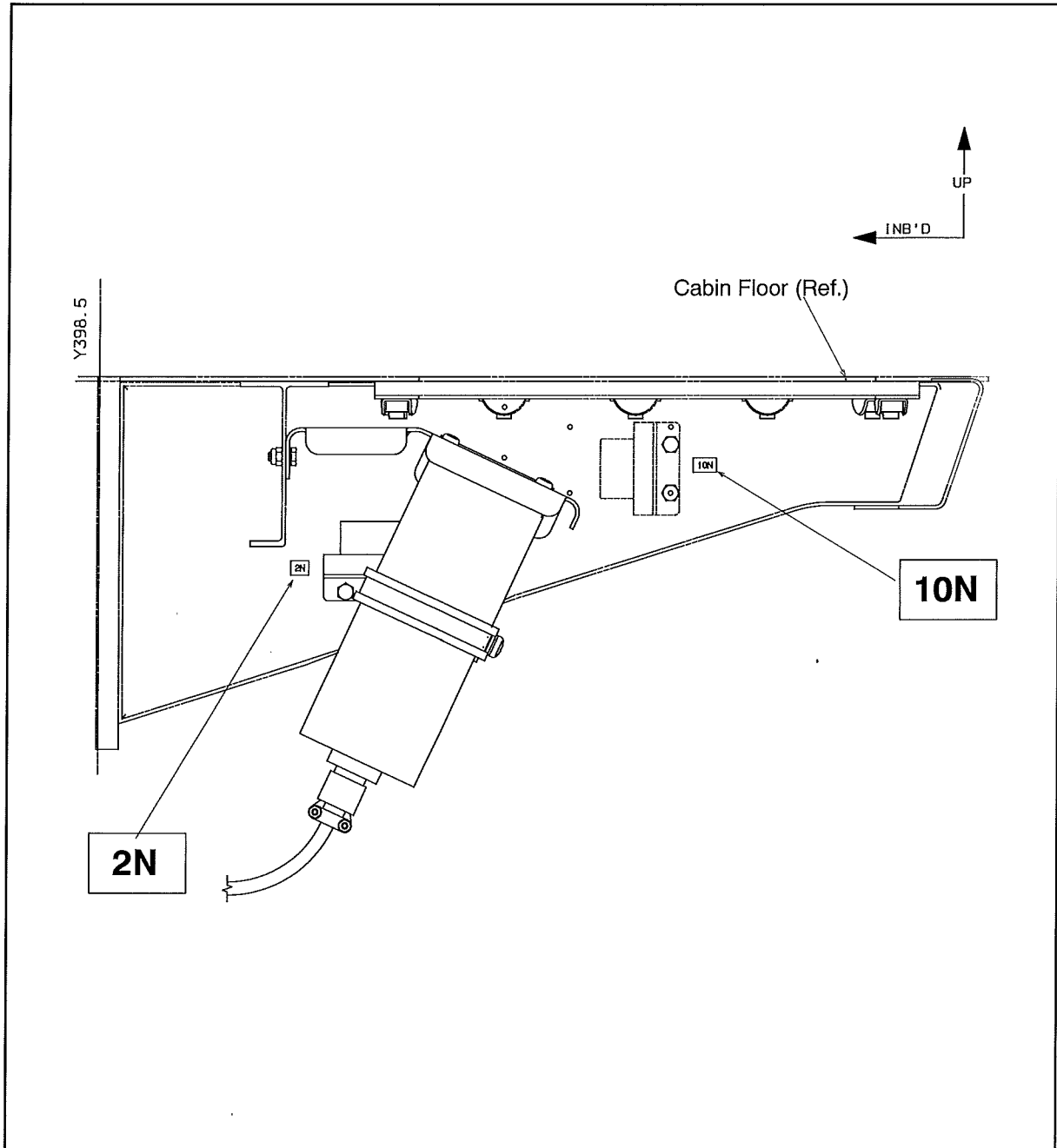

Figure 21 Placards on RHS bulkhead with Floor-Mounted Torque Indicator Option
(aircraft with Floor Seat Rail Support shown)

Transport Canada Accepted

