



SUBJECT:

Required maintenance for the Installation of Forward Short High-Visibility Doors
(P/N 350-202414).

APPLICABILITY :

Aircraft with the subject modification embodied in accordance with TCCA STC NO. SH05-18
or any relevant foreign approvals.

THE INFORMATION CONTAINED IN THIS DOCUMENT SHALL BE TREATED AS THE PROPERTY OF EUROCOPTER CANADA LIMITED (ECL). THE RECIPIENT OF THIS DOCUMENT SHALL NOT DISCLOSE ANY INFORMATION CONTAINED HEREIN TO THIRD PARTIES WITHOUT THE WRITTEN PERMISSION OF ECL, AND SHALL NOT USE OR REPRODUCE THIS DOCUMENT IN WHOLE OR IN PART FOR ANY PURPOSE OTHER THAN ITS ORIGINALLY INTENDED PURPOSE, OR TO EVALUATE ITS CONTENTS.

	NAME AND SIGNATURE	DATE	COMPANY DEPARTMENT
PREPARED BY:	D. Kerr <i>DKerr</i>	1 April 2013	ECL ENGINEERING
PREPARED BY:			
CHECKED BY:	C. Timmins <i>C. Timmins</i>	1 st April 2013	ECL ENGINEERING
CHECKED BY:	M. Merritt <i>M. Merritt</i>	2013 04 01	ECL QUALITY ASSURANCE
APPROVED / ACCEPTED (Civil A/W Authority)	(AS per ICA Compliance Check Sheet) <i>G. David</i>	16 April 2013	TCCA
RELEASED BY:	P. Sharpe <i>P. Sharpe</i>	18 April 2013	ECL ENGINEERING



RECORD OF REVISIONS

Rev.	Pages at this Revision	Description, Reason, Changed Pages	Prepared (name and date)	Checked (name and date)	App'd/Acc'd (Civil A/W Authority) (name and date)	Released (name and date)
0	1 through 15	Original Issue	D. Kerr 9 March 2005	C. Timmins 10 March 2005	TCCA E. Cheung 1 April 2005	R. Manson 1 April 2005
1	1 through 18	Revised format. Increased 500 hr. inspection to 600 hrs. in Section 4. Document title revised to match STC description. (Pages 1 to 18)	D. Kerr 29 September 2010	C. Timmins 29 September 2010	N/A	P. Sharpe 18 March 2013
2	1 through 20	Revised the Airworthiness Limitations statement in Section 2. Addition of the AS 350 B2/B3 AMM. Inspection margins added to Section 4. (Pages 3, 5 & 10- 17)	See Page 1.	See Page 1.	See Page 1.	See Page 1.

NOTE: Revisions to this document will be distributed to operators of this equipment by the STC holder.
NOTE: Revised portions of affected pages are identified by a vertical black line in the margin adjacent to the change.

Transport Canada - Accepted



CONTENTS

SECTION	TITLE	PAGE
1	GENERAL	4
2	AIRWORTHINESS LIMITATIONS	11
3	CONTROL AND OPERATION	12
4	INSPECTION SCHEDULE AND MAINTENANCE ACTION	12
5	REPLACEMENT COMPONENTS AND REPAIR/OVERHAUL INFORMATION ..	15
6	TROUBLESHOOTING	15
7	SPECIAL TOOLING	15
8	REMOVAL AND REPLACEMENT	16
9	WEIGHT AND BALANCE DATA	18
10	PLACARDS AND MARKINGS	19

FIGURES

FIGURE	TITLE	PAGE
1	General Layout	4
2	Door Hinge Details	5
3	Upper and Lower Door Latch Details	6
4	Center Door Latch and Door and Window Seal Details	7
5	Door Details	8
6	Jettison Details	9
7	Identification label on the LH and RH Jettison Handle Cover (LH Shown)	19
8	Identification label on the LH and RH door latch (LH Shown)	20

TABLES

TABLE	TITLE	PAGE
1	Inspection Schedule and Maintenance Action Every 150 FH 12 M (Margins: 15 FH or 36 D)	12
2	Inspection Schedule and Maintenance Action Every 600 FH or 24 M (Margins: 60 FH or 73D)	15

Transport Canada - Accepted



1. GENERAL

- A. The Eurocopter Canada Limited Forward Short High-Visibility Doors are available as an alternative to the standard Pilot and Co-Pilot Doors.

The Forward Short High-Visibility Doors provide the cabin occupants with an increased level of visibility when compared to the standard Pilot and Co-Pilot Doors.

The doors are attached to the cabin using standard AS 350 hinges and hardware and are completely interchangeable with the standard AS 350 cabin doors. Refer to Figure 1.

The installation is available in the following configurations:

- 01 variant - Door Assy, Hi-Vis, LH, Short, Clear
- 02 variant - Door Assy, Hi-Vis, RH, Short, Clear
- 03 variant - Door Assy, Hi-Vis, LH, Short, Tint
- 04 variant - Door Assy, Hi-Vis, RH, Short, Tint

For instructions on initial installation, see IP-ECL-112.

- B. These Instructions for Continued Airworthiness are applicable to aircraft with the subject modification embodied.

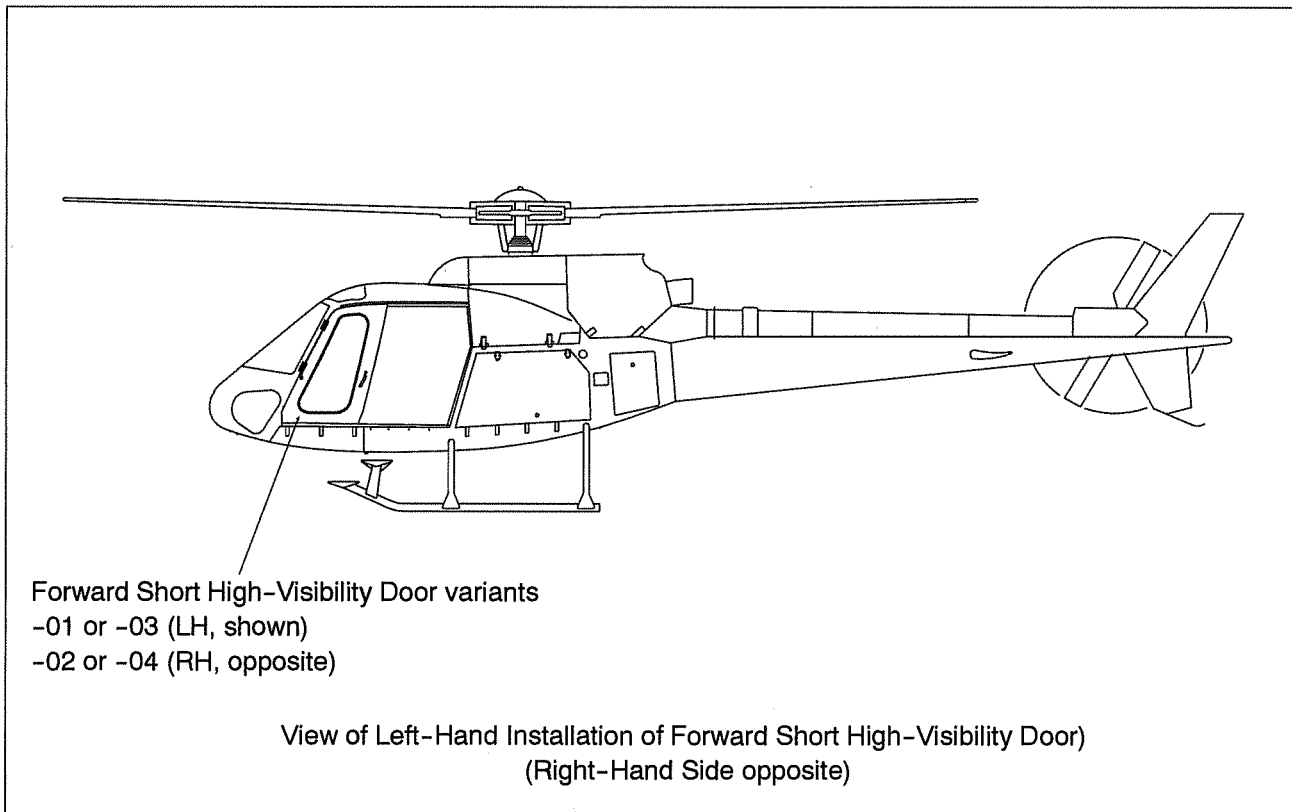

Figure 1 General Layout

Transport Canada - Accepted



Legend (for Figure 2)

Item Description

1. Hinge Doubler
2. Hinge Half
3. Upper Rod Assembly
4. Plain Pin
5. Washer
6. Split Pin
7. Sealant (P/N PR1422-B2)
8. Rivets (P/N MS20426AD-5-8)

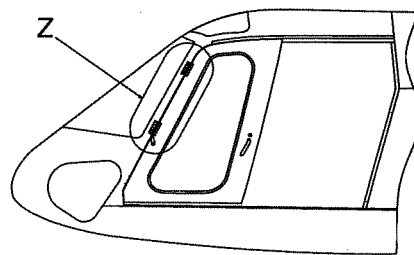

Existing Hinge (ref.)

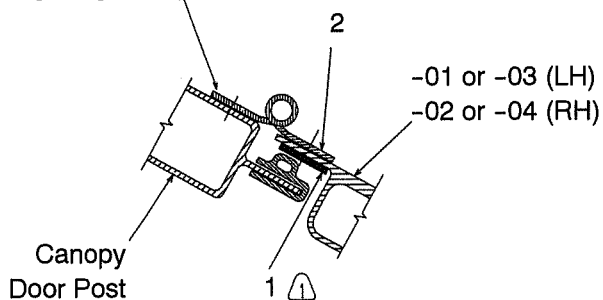

SECTION X - X
(2 places)

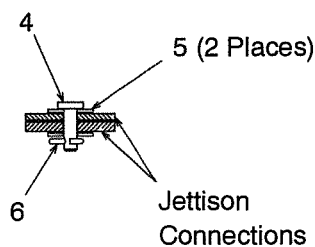

SECTION Y - Y

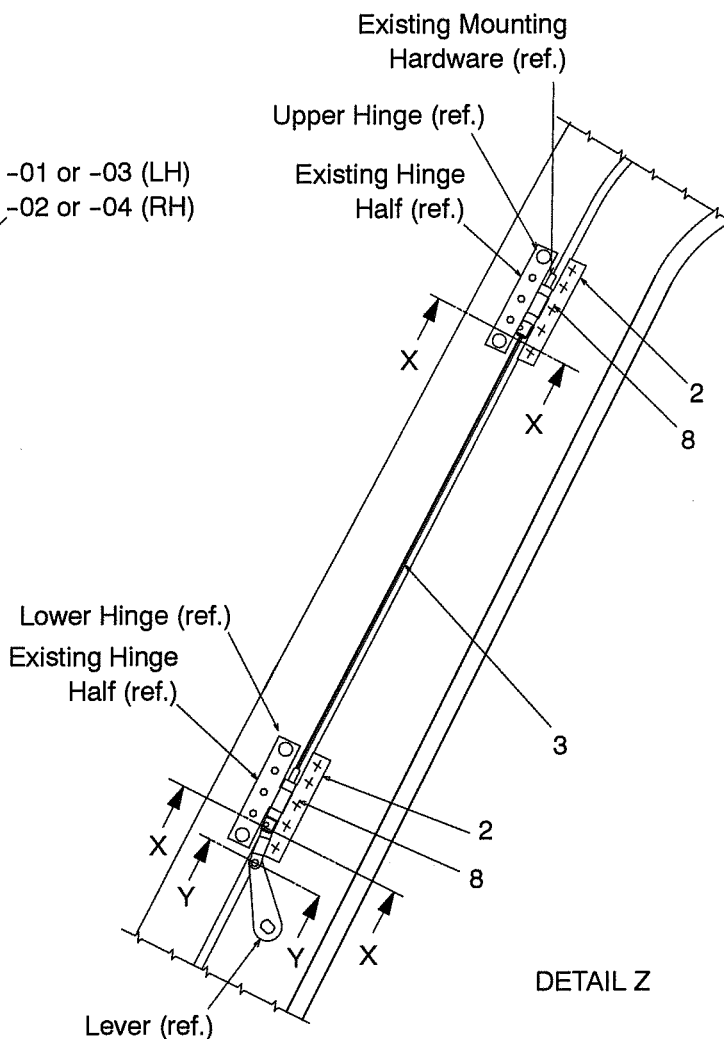

DETAIL Z

⚠ Apply sealant (item 7) on faying surface between hinge doublers (item 1) and doors -01 or -03 (LH), -02 or -04 (RH). Also use sealant to ensure a smooth transition for the door seal over hinge doublers

NOTES:

Figure 2 Door Hinge Details

Transport Canada - Accepted



Legend (for Figure 3)

Item Description

- 1. Seal (Adhesive backing)
- 2. Seal Retainer
- 3. Door Seal

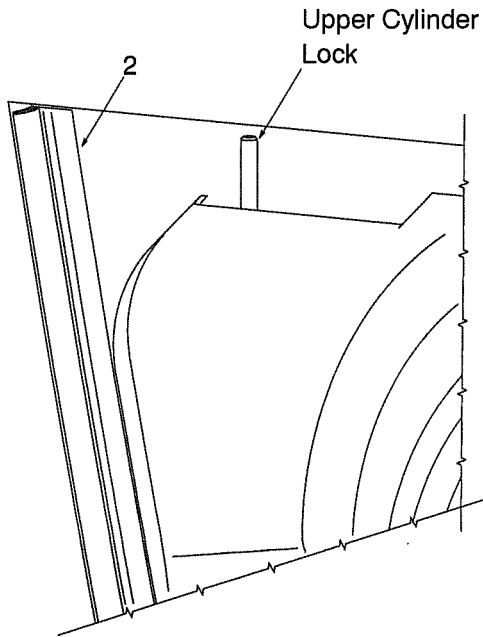

DETAIL Z
Upper Latch, LH shown, RH similar

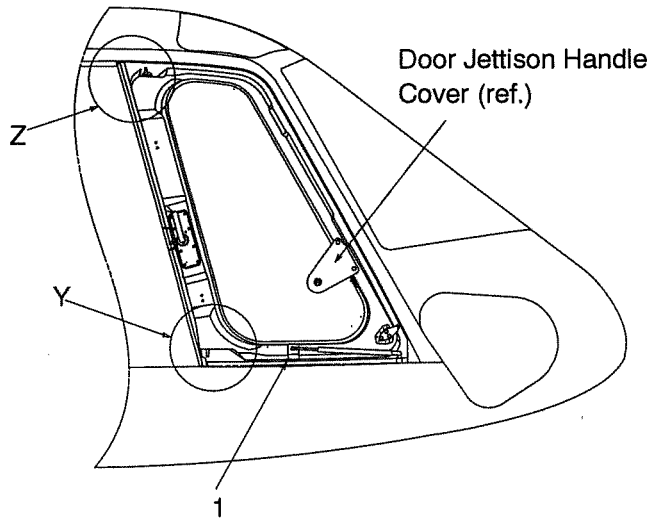

VIEW LOOKING OUTBOARD
OF LEFT HAND SIDE

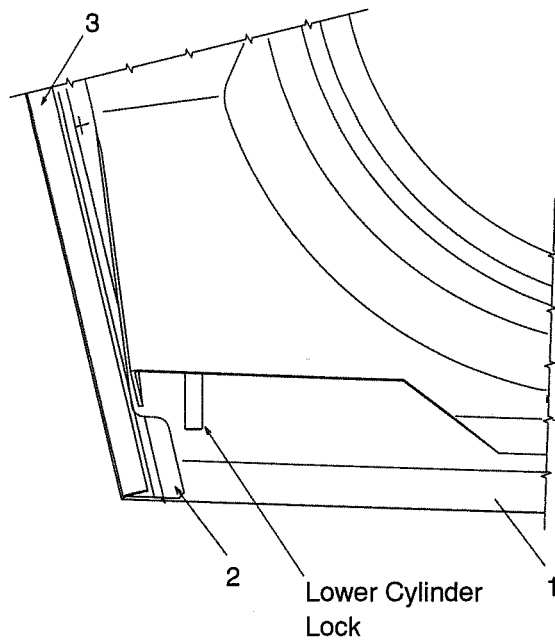

DETAIL Y
Shown normal to latch axis
Lower Latch, LH shown, RH similar

Figure 3 Upper and Lower Door Latch Details

Transport Canada - Accepted



Legend (for Figure 4)

Item Description

- 1. Lock Bracket
- 2. Pin
- 3. Handle
- 4. Door Seal
- 5. Seal Retainer
- 6. Sealant (PR1422-B2)

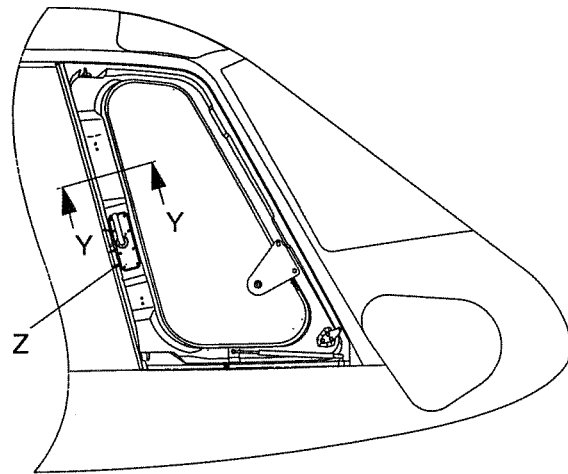

VIEW LOOKING OUTBOARD
OF LEFT HAND SIDE

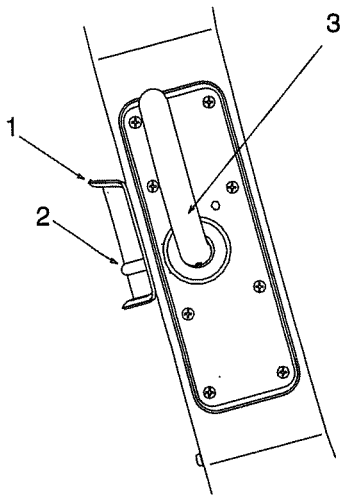

DETAIL Z

Center Door Latch LH shown, RH
similar

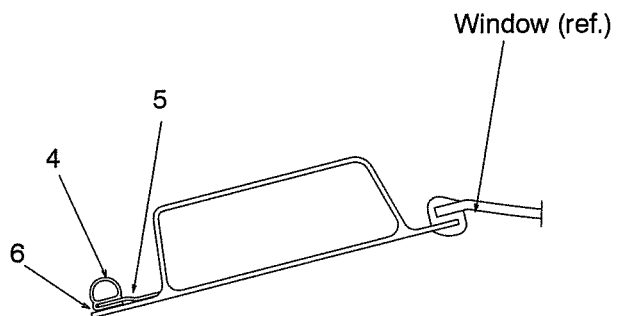

SECTION Y - Y

Cut away showing door seal and
window seal

Figure 4 Center Door Latch and Door and Window Seal Details

Transport Canada - Accepted



Legend (for Figure 5)

Item Description

- 1. Window
- 2. Window Seal
- 3. Guide Assembly - See ⚠
- 4. Door Mechanism
- 5. Door Jettison Control Lever
- 6. Jettison Spring

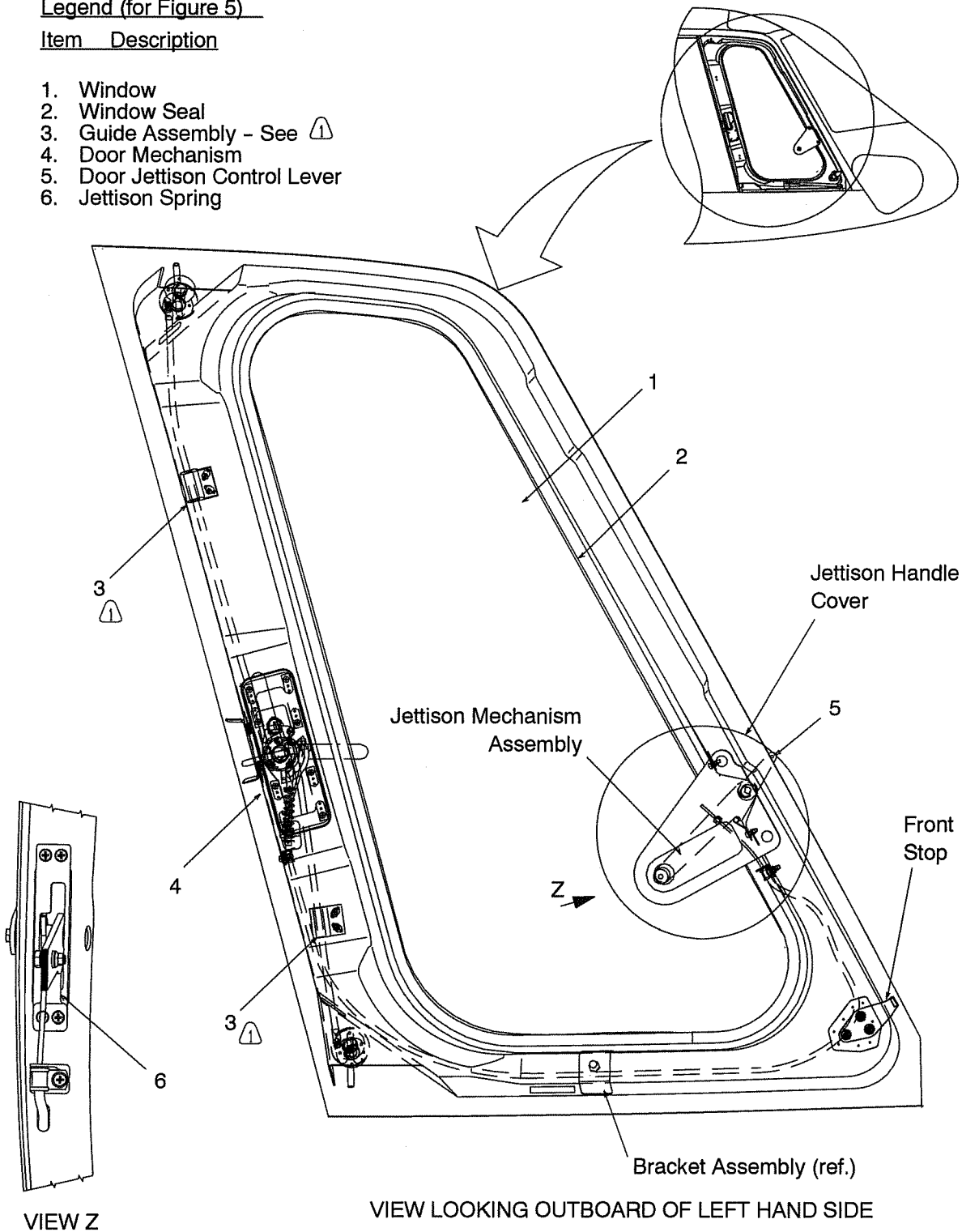

⚠ Adjust guide assembly, item 3, position to ensure functionality of door mechanism (item 4).
NOTES:

Figure 5 Door Details

Transport Canada - Accepted



Legend (for Figure 6)

Item Description

- 1 Jettison Cable
- 2 Lever
- 3 Angle
- 4 Clamp
- 5 Cable Assembly
- 6 Bracket
- 7 Handle
- 8 Screw
- 9 Washer
- 10 Nut
- 11 Spacer
- 12 Bolt
- 13 Hollow Washer
- 14 Spacer
- 15 Shaft

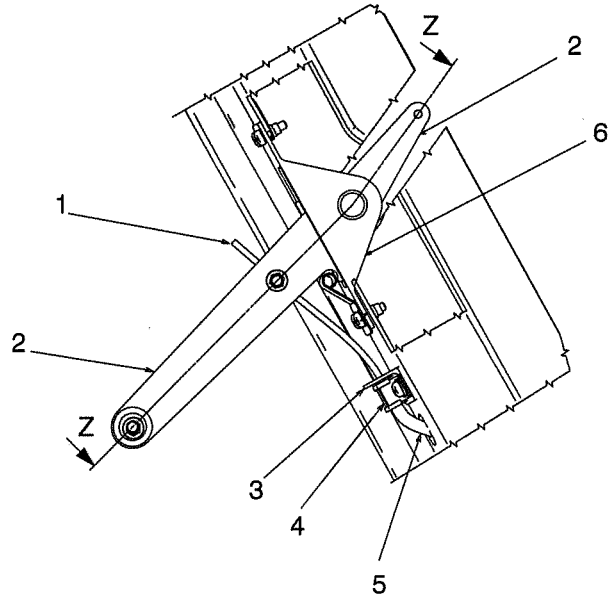

Jettison Details
(Handle removed for clarity)

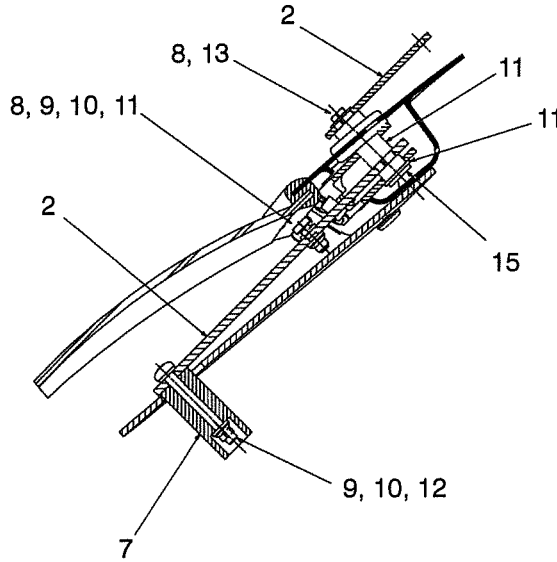

SECTION Z - Z

Figure 6 Jettison Details

Transport Canada - Accepted



C. REFERENCES

DOCUMENT	DOCUMENT TITLE
AC -43.13 - 1B	Advisory Circular No. 43.13-1B
AMM	Aircraft Maintenance Manual
IP-ECL-112	Installation Procedure, Installation of Forward Short High-Visibility Doors
MET	Maintenance Manual
MRM	Mechanical Repair Manual
MRS	Structural Repair Manual
MTC	Standard Practices Manual

D. ABBREVIATIONS & DEFINITIONS

ABBREVIATION	DEFINITION
D	Days
EC	Eurocopter (France)
ECL	Eurocopter Canada Limited
FH	Flight Hours
hrs	hours
LH	Left-Hand
M	Months
P/N	Part Number
RH	Right-Hand
Vis	Visibility

E. UNITS OF MEASUREMENT

ABBREVIATION / SYMBOL	UNIT OF MEASUREMENT
in	inch
in.lb	inch.pound
kg	kilogram
lbs	pounds
m	meter
m daN	meter deca newton
m kg	meter kilogram

Transport Canada - Accepted

2. AIRWORTHINESS LIMITATIONS

The Airworthiness Limitations section is approved by the Minister and specifies maintenance required by any applicable airworthiness or operating rule unless an alternative program has been approved by the Minister. Variations must also be approved.

The Airworthiness Limitations section is FAA approved and specifies inspections and other maintenance required under Sections 43.16 and 91.403 of the Federal Aviation Regulations unless an alternative program has been FAA approved.

No airworthiness limitations associated with this installation.

Transport Canada - Approved



3. CONTROL AND OPERATION

Control and operation of the aircraft remains unchanged.

4. INSPECTION SCHEDULE AND MAINTENANCE ACTION

NOTE: Use torque per MTC, Volume 2, Chapter 20.02.05.404, unless otherwise specified.

4.1. INSPECTION SCHEDULE

4.1.1. Every 150 FH or 12 M (Margins: 15 FH or 36 D) to coincide with the 150 FH or 12 M helicopter inspection, whichever occurs first:

ITEM	INSPECTION OR MAINTENANCE WORK	CORRECTIVE ACTION
A	- Visually inspect the Forward Short High-Visibility Doors for: a. cracking, delamination or surface irregularity	a. Repair in accordance with MTC, Chapter 20-03-07-101.
B	- Visually inspect mounting hardware and door hinge halves, in Figure 2 for: a. secure installation b. corrosion	a. Ensure that hinge pins are inserted all the way into hinge half. Retighten as required. b. No corrosion is allowed. If corrosion is found replace in accordance with AS 350 (except B2/B3) MRM, Chapter 52.10.10.701. For AS 350 B2/B3 refer to AMM, 52-11-00, 4-2.
C	- Visually inspect door strut, in Figure 3, for: a. secure installation b. correct operation	a. Ensure that the door strut is connected correctly to door and fuselage attachments. b. If door strut does not hold door in the open position, contact ECL for replacement part.

Table 1 Inspection Schedule and Maintenance Action
Every 150 FH or 12 M, to coincide with the 150 FH or 12 M helicopter inspection, whichever occurs first
(continued on following page)

Transport Canada - Accepted



4. **INSPECTION SCHEDULE AND MAINTENANCE ACTION** (continued)

4.1.1. Every 150 FH or 12 M (Margins: 15 FH or 36 D) to coincide with the 150 FH or 12 M helicopter inspection, whichever occurs first:

ITEM	INSPECTION OR MAINTENANCE WORK	CORRECTIVE ACTION
D	<ul style="list-style-type: none"> - Visually inspect seal, item 1, and door seal, item 3, in Figure 3, for: <ul style="list-style-type: none"> a. cuts and cracking b. debonding or loss of elasticity c. security 	<ul style="list-style-type: none"> a. If cuts or cracks are evident replace door seal. b. If debonding or loss of elasticity is evident, contact ECL for replacement parts. Trim item 1 as required to seal around door and secure using adhesive backing. If replacing item 3 replace in accordance with AS 350 (except B2/B3), MRS, Chapter 52.91.12.00 For AS 350 B2/B3, refer to AMM, Chapter 52-00-00, 4-1a or b. c. Secure as required.
E	<ul style="list-style-type: none"> - Test door latches, in Figures 3 and 4, for: <ul style="list-style-type: none"> a. freedom of movement 	<ul style="list-style-type: none"> a. Clean and lubricate with aeroshell 22 to restore freedom of movement. Adjust guide assembly position to ensure functionality of door mechanism.
F	<ul style="list-style-type: none"> - Visually inspect sealant, item 6 in Figure 4, for: <ul style="list-style-type: none"> a. condition 	<ul style="list-style-type: none"> a. If sealant has become debonded, clean area and reapply sealant, item 6, along edge of door seal, item 4 in accordance with MTC, Chapter 20-05-01-206.
G	<ul style="list-style-type: none"> - Perform functional test of door locking mechanism, in Figure 4, for: <ul style="list-style-type: none"> a. proper locking 	<ul style="list-style-type: none"> a. Adjust pin (2) as required to ensure adequate seal between the door and door seal.
H	<ul style="list-style-type: none"> - Visually inspect window, item 1, in Figure 5, for: <ul style="list-style-type: none"> a. cracking 	<ul style="list-style-type: none"> a. If cracking is evident replace window in accordance with AS 350 (except AS 350 B2/B3) MET, Chapter 52.00.00.401. For AS 350 B2/B3 refer to AMM, Chapter 56-11-00, 4-3.

Table 1 Inspection Schedule and Maintenance Action
Every 150 FH or 12 M, to coincide with the 150 FH or 12 M helicopter inspection, whichever occurs first
(continued on following page)

Transport Canada - Accepted

4. **INSPECTION SCHEDULE AND MAINTENANCE ACTION** (continued)

4.1.1. Every 150 FH or 12 M (Margins: 15 FH or 36 D) to coincide with the 150 FH or 12 M helicopter inspection, whichever occurs first:

ITEM	INSPECTION OR MAINTENANCE WORK	CORRECTIVE ACTION
I	- Visually inspect window seal, item 2 in Figure 5, for: a. condition	a. If cuts or cracks are evident replace window seal in accordance with AS 350 (except AS 350 B2/B3), MET, Chapter 52.00.00.401. For AS 350 B2/B3 refer to AMM, Chapter 56-11-00, 4-3.
J	- Check Jettison handle mounting hardware, items 9, 10 and 12 in Figure 6 for: a. security	a. Secure as required.
K	- Check Jettison cable mounting hardware, items 8, 9, 10 and 11 in Figure 6 for: a. security	a. Secure as required.
L	- Check lever mounting hardware, items 8, 11, and 13 in Figure 6 for: a. security	a. Secure as required.
M	- Check placards and markings (refer to Section 10) for: a. legibility b. secure mounting	a. If placard has become illegible, contact ECL for replacement parts. b. Secure and reattach placards as required.

Table 1 Inspection Schedule and Maintenance Action
Every 150 FH or 12 M, to coincide with the 150 FH or 12 M helicopter inspection, whichever occurs first

Transport Canada - Accepted



4. INSPECTION SCHEDULE AND MAINTENANCE ACTION (continued)

4.1.2. Every 600 FH or 24 M (Margin: 60 FH or 73D) to coincide with the 600 FH or 24 M helicopter inspection, whichever occurs first:

ITEM	INSPECTION OR MAINTENANCE WORK	CORRECTIVE ACTION
A	<ul style="list-style-type: none"> - Inspect door jettison control lever, item 5, in Figure 5 for: <ul style="list-style-type: none"> a. correct operation (For maximum release load refer to the AS 350 (except AS 350 B2/B3) MET, Chapter 52.10.00.501. For AS 350 B2/B3 refer to AMM, Chapter 52-11-00, 5-1) 	<ul style="list-style-type: none"> a. Adjust jettison mechanism in accordance with AS 350 (except AS 350 B2/B3) MET, Chapter 52.10.00.501. For AS 350 B2/B3 refer to AMM, Chapter 52-11-00, 5-1.

Table 2 Inspection Schedule and Maintenance Action
Every 600 FH or 24 M, to coincide with 600 FH or 24 M helicopter inspection, whichever occurs first

5. REPLACEMENT COMPONENTS AND REPAIR / OVERHAUL INFORMATION

No replacement components and repair/overhaul information required for this installation.

6. TROUBLESHOOTING

There are no unique characteristics which require troubleshooting techniques.

7. SPECIAL TOOLING

No special test equipment or tools are required. Standard tools are adequate.

Transport Canada - Accepted

8. REMOVAL AND REPLACEMENT

Proceed as follows if any of these need to be removed.

PRELIMINARIES

A. For AS 350 (except B2/B3):

- Read the General Electrical Instructions (refer to AS 350 Maintenance Manual, Chapter 24.00.00.301).
- set the "D.BAT" push button to "OFF"
- set the "EXT PWR BAT" pushbutton to "OFF" (refer to Electrical Power AS 350 Maintenance Manual, Chapter 24.00.00.301)
- disconnect the external power unit and battery (refer to Removal/ Installation AS 350 Maintenance Manual, Chapter 24.30.00.401)

B. For AS 350 B2/B3:

- Read General Safety Instructions - Electrical Power Supply System (refer to AS 350 B2/B3 Aircraft Maintenance Manual, Chapter 24-00-00, 3-1)
- Read Electrical Power Supply on the Ground (refer to AS 350 B2/B3 Aircraft Maintenance Manual, Chapter 24-00-00, 2-1)
- disconnect the external power unit and battery (refer to Removal/Installation, AS 350 B2/B3 Aircraft Maintenance Manual, Chapter 24-33-00, 4-1)

A. REMOVAL

1) FORWARD SHORT HIGH-VISIBILITY DOORS (Refer to Figures 2 to 5)

- a) Disconnect door strut from door joint ball and remove upper rod assembly (3) and hinge pins.
- b) Pull door handle up to open door. Pull jettison lever up to remove door. Place door on work bench.

Transport Canada - Accepted

8. **REMOVAL AND REPLACEMENT** (continued)

B. REPLACEMENT

NOTE Use torque per MTC, Volume 2, Chapter 20.02.05.404 unless otherwise specified.

Comply with general safety instructions for the mechanical assemblies:

- For AS 350 (except AS 350 B2/B3) refer to MET, Chapter 60.00.00.301.
- For the AS 350 B2/B3 refer to AMM, Chapter 60-00-00, 3-1.

1) FORWARD SHORT HIGH-VISIBILITY DOORS (Refer to Figures 2 to 5)

- a) Place door in door opening and install hinge pins and upper rod assembly (3).
- b) Reconnect door strut to door joint ball.

2) AS 350:

- Apply external power unit and battery. Refer to AS 350 MET, Chapter 24.30.00.401.
- Perform functional test - DC Power Supply in accordance with AS 350 MET, Chapter 24.30.00.501.

3) AS 350 B2/B3:

- Before energizing the aircraft power supply system, read safety instructions (refer to General Safety Instruction - Electrical Power Supply System, AS 350 B2/B3, AMM, Chapter 24-00-00, 3-1).
- Reconnect the external power unit and battery (refer to Removal/Installation AS 350 B2/B3 AMM, Chapter 24-33-00, 4-1).
- Perform functional test - DC Power Supply System in accordance with AS 350 B2/B3 AMM, Chapter 24-30-00-5-1.

4) Do a function test of the crew door(s).

- For the AS 350 (except AS 350 B2/B3) refer to Adjustment/Test - Cabin Door, MET, Chapter 52.10.00.502.
- For the AS 350 B2/B3 refer to Adjustment/Test - Crew Door, AMM, Chapter 52-11-00, 5-2.

5) Perform Jettison Test

- For the AS 350 (excluding AS 350 B2/B3) refer to MET, Chapter 52.10.00.501.
- For the AS 350 B2/B3 refer to AMM, Chapter 52-11-00, 5-1.
- With door reinstalled, lubricate hinge pins with grease (P/N G.355 or G.361). Visually check that the hinge pins are fitted correctly and check condition of the jettison control rod.

6) Verify that the installation of the Forward Short High-Visibility Doors is correct and secure.

- Ensure that the door latches operate smoothly and freely after installation.
- Move door handle on FWD door down: the door swings outward in the FWD direction.
- Ensure that the hinge pins are inserted all the way into hinge half (34).
- Ensure that the door strut is connected correctly; holding the door in the open position.
- Ensure proper operation of the sliding door with the front door closed.

Transport Canada - Accepted



9. WEIGHT AND BALANCE DATA

A. Removed Items						
DESCRIPTION	WEIGHT		ARM		MOMENT	
	kg	lb	m	in	kg m	lb in
Door Installation, Reduced, RH	7.85	17.3	1.56	61.4	12.25	1062.2
Door Installation, Reduced, LH	7.85	17.3	1.56	61.4	12.25	1062.2
Total	15.70	34.6	1.56	61.4	24.49	2124.4

B. Added Items						
DESCRIPTION	WEIGHT		ARM		MOMENT	
	kg	lb	m	in	kg m	lb in
High Visibility Door, Short, RH	8.00	17.6	1.56	61.4	12.48	1080.6
High Visibility Door, Short, LH	8.00	17.6	1.56	61.4	12.48	1080.6
Total	16.0	35.2	1.56	61.4	24.96	2161.3

Transport Canada - Accepted

10. **PLACARDS AND MARKINGS**

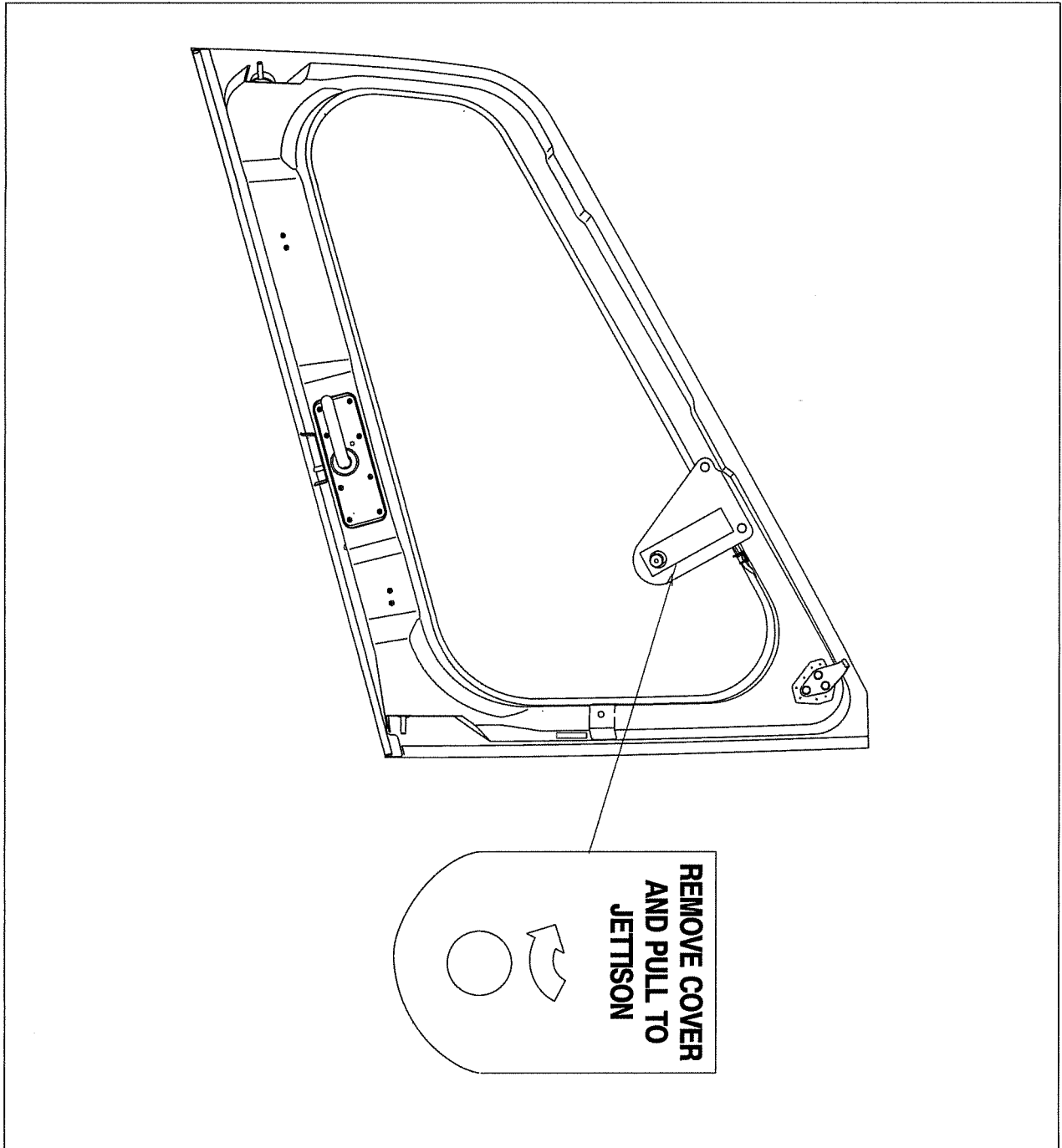

Figure 7 Identification label on the LH and RH Jettison Handle Cover (LH shown)

Transport Canada - Accepted

10. **PLACARDS AND MARKINGS** (continued)

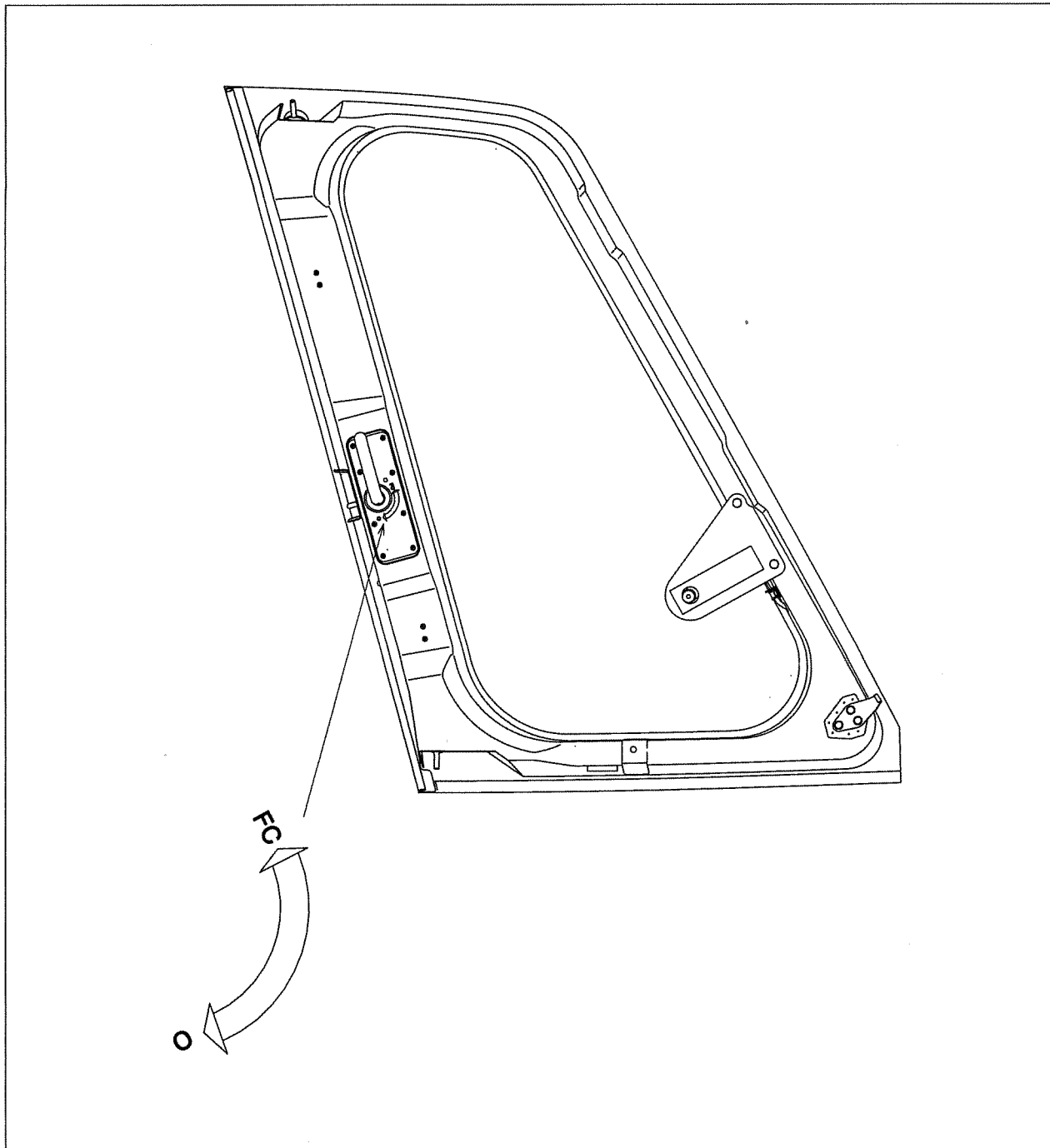

Figure 8 Identification label on the LH and RH door latch (LH shown)

Transport Canada - Accepted