

**SUBJECT: INSTALLATION OF LEFT HAND AND / OR RIGHT HAND CARGO
 MIRRORS (P/N 350-200254/64)**

This Flight Manual Supplement describes operation with the Left Hand And / Or Right Hand Cargo Mirrors installed.

APPLICABILITY:

This Flight Manual Supplement shall be used when the Left Hand And / Or Right Hand Cargo Mirrors are installed on the helicopter.

Department of Transport
 (Canada) Approved

IMPORTANT NOTE

THE INFORMATION AND DATA CONTAINED IN THIS DOCUMENT SUPERSEDE OR SUPPLEMENTS THAT CONTAINED IN THE BASIC APPROVED FLIGHT MANUAL FOR THE AS 350 OR AS 355 HELICOPTER IN THOSE AREAS LISTED HEREIN. FOR LIMITATIONS, PROCEDURES AND PERFORMANCE NOT CONTAINED IN THIS DOCUMENT REFER TO THE APPROVED FLIGHT MANUAL AND OTHER APPLICABLE APPROVED FLIGHT MANUAL SUPPLEMENTS.

SECTIONS 2, 3, 4, AND 5 OF THIS DOCUMENT COMPRISE THE APPROVED FLIGHT MANUAL SUPPLEMENT. COMPLIANCE WITH SECTION 2, LIMITATIONS, IS MANDATORY.

SECTIONS 1 AND 6 ARE UNAPPROVED AND ARE PROVIDED FOR INFORMATION ONLY.

CANADA	
DEPARTMENT OF TRANSPORT AIRCRAFT CERTIFICATION BRANCH	
MAY 08 2020	
APPROVED	
BY: _____	<i>David</i>
CERTIFICATE NO. _____	SH96-61
ISSUE NO. _____	5

THE INFORMATION CONTAINED IN THIS DOCUMENT SHALL BE TREATED AS THE PROPERTY OF AIRBUS HELICOPTERS CANADA LIMITED (AHCA). THE RECIPIENT OF THIS DOCUMENT SHALL NOT DISCLOSE ANY INFORMATION CONTAINED HEREIN TO THIRD PARTIES WITHOUT THE WRITTEN PERMISSION OF AHCA, AND SHALL NOT USE OR REPRODUCE THIS DOCUMENT IN WHOLE OR IN PART FOR ANY PURPOSE OTHER THAN ITS ORIGINALLY INTENDED PURPOSE, OR TO EVALUATE ITS CONTENTS.

	NAME AND SIGNATURE	DATE	COMPANY DEPARTMENT
PREPARED BY:	D. Kerr <i>DK</i>	28 April 2020	AHCA ENGINEERING
PREPARED BY:			
CHECKED BY:	G. Krebs <i>GK</i>	14/4/2020	AHI TEST PILOT
CHECKED BY:	P. Sharpe <i>PS</i>	25 APRIL 2020	AHCA ENGINEERING
REV. 1 ACCEPTED (Civil A/W Authority)			TCCA
REV. 1 RELEASED BY:	P. Sharpe <i>PS</i>	12 MAY 2020	AHCA ENGINEERING

CONTENTS

SECTION	TITLE	PAGE
1	GENERAL	4
2	LIMITATIONS	6
3	EMERGENCY AND MALFUNCTION PROCEDURES	6
4	NORMAL PROCEDURES	6
5	PERFORMANCE DATA	6
6	MASS AND BALANCE	7

FIGURES

FIGURE	TITLE	PAGE
1	General Layout	4

Transport Canada Approved

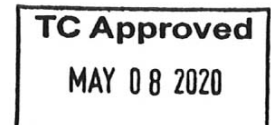

1. GENERAL (unapproved)

The Installation of Left Hand and / or Right Hand Cargo Mirrors consists of two mirrors mounted on a support frame that is fixed to the helicopter at three attachment points on the LH side or RH side of the aircraft. One mirror is used to monitor the load while the other is used to monitor the hook. The mirrors must be manually adjusted while on the ground to enable the pilot to watch the external load and monitor hook while monitoring the instrument panel. Refer to Figure 1 for General Layout.

The cargo mirrors can easily be removed between aerial missions and must be readjusted upon installation.

The Installation of Left Hand and / or Right Hand Cargo Mirrors is possible in the following configurations:

- 01 - used for low AHCA mirror configuration
- 02 - used for low AH mirror configuration
- 03 - used for standard AHCA mirror configuration
- 04 - used for standard AH mirror configuration

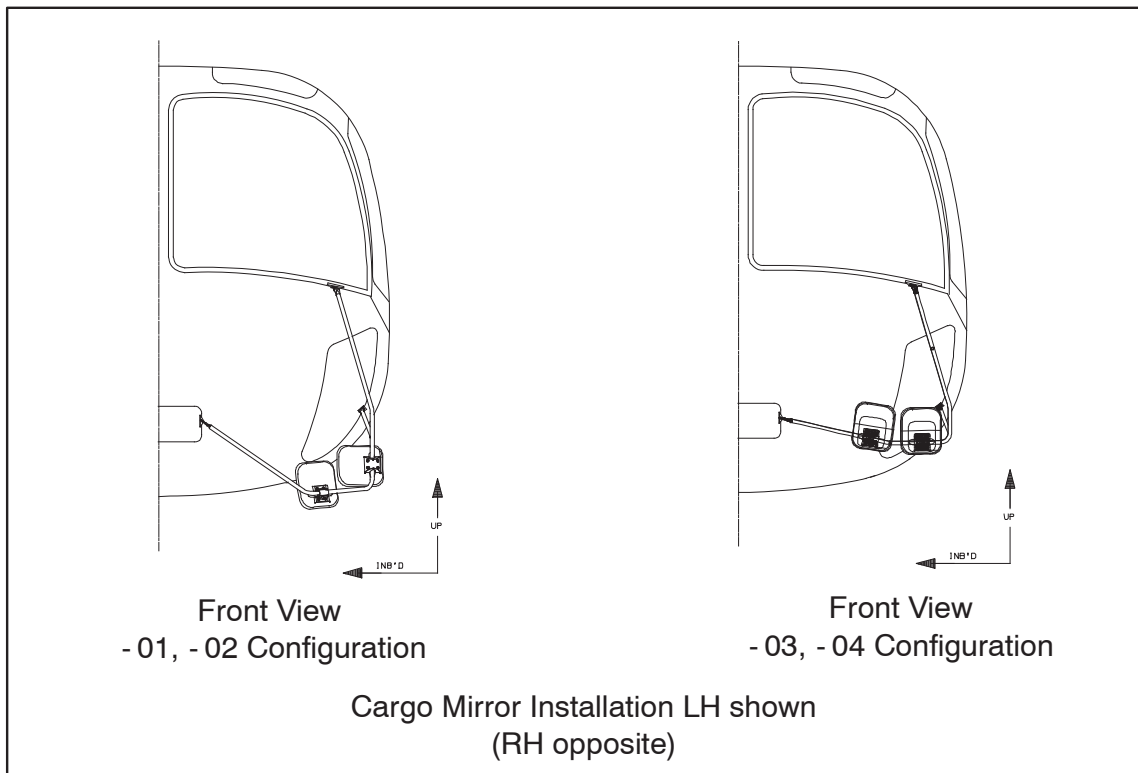

Figure 1 General Layout

Transport Canada - Unapproved

1. GENERAL (continued)

Abbreviations and Definitions

ABBREVIATION	DEFINITION
Acc'd	Accepted
AH	Airbus Helicopters (France)
AHCA	Airbus Helicopters Canada Limited
AHI	Airbus Helicopters Incorporated
App'd	Approved
A/W	Airworthiness
CAR	Canadian Aviation Regulations
DAPM	Design Approval Procedures Manual
FMS	Flight Manual Supplement
ICA	Instructions for Continued Airworthiness
km/h	kilometers per hour
kt	knot
LH	Left Hand
mph	miles per hour
P/N	Part Number
Rev.	Revision
RH	Right Hand
STC	Supplemental Type Certificate
TCCA	Transport Canada Civil Aviation
VFR	Visual Flight Rules
VNE	Never Exceed Speed

Transport Canada - Unapproved

2. LIMITATIONS

The normal procedures specified in the basic Flight Manual remain applicable except for the following when this modification is installed:

a. **Operation**

Operation with the Cargo Mirror Installation installed is limited to day and night VFR operation only.

b. **For AS 350 only**

Maximum indicated airspeed with Left Hand and Right Hand Cargo Mirrors installed

VNE power on: 145 kt (268 km/h or 166 mph)

3. EMERGENCY AND MALFUNCTION PROCEDURES

No change to existing approved Flight Manual.

4. NORMAL PROCEDURES

a. **Before the first flight of each day**

Required before the first flight of each day:

- | | |
|-----------|---|
| Condition | - Clean mirror. Replace mirror if broken. Check mirror casing for cracking. |
| Security | - Ensure Cargo Mirror Installation is secure. |

5. PERFORMANCE DATA

No change to existing approved Flight Manual.

6. MASS AND BALANCE (unapproved)

Total changes to weight and balance resulting from this modification are covered in this applicable Instructions for Continued Airworthiness (ICA).

Items that are removed between routine operations: Not applicable.