

EUROCOPTER CANADA LIMITED

SUBJECT:

Required maintenance for the Spectrolab SX-16 Nightsun Searchlight (P/N 120-901234-01 and 120-901234-03 with RH Pilot's Cyclic Control, P/N 120-901234-02 and 120-901234-04 without RH Pilot's Cyclic Control and P/N 120-901234-05 with SLASS).

NOTE The Spectrolab SX-16 Nightsun Searchlight Installation has been designed for operation with the pilot-in-command occupying the RH seat.

APPLICABILITY :

Aircraft with the subject modification embodied in accordance with TCCA STC. No. SH03-15 or any relevant foreign approvals.

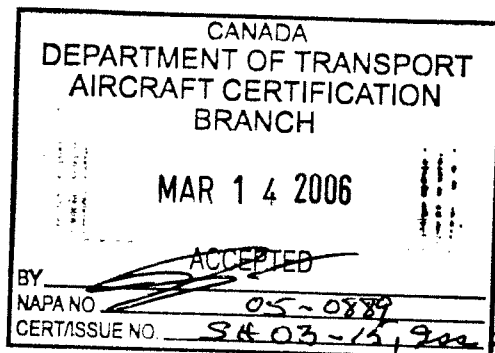

THE INFORMATION CONTAINED IN THIS DOCUMENT SHALL BE TREATED AS THE PROPERTY OF EUROCOPTER CANADA LIMITED (ECL). THE RECIPIENT OF THIS DOCUMENT SHALL NOT DISCLOSE ANY INFORMATION CONTAINED HEREIN TO THIRD PARTIES WITHOUT THE WRITTEN PERMISSION OF ECL, AND SHALL NOT USE OR REPRODUCE THIS DOCUMENT IN WHOLE OR IN PART FOR ANY PURPOSE OTHER THAN ITS ORIGINALLY INTENDED PURPOSE, OR TO EVALUATE ITS CONTENTS.

	NAME AND SIGNATURE	DATE	COMPANY DEPARTMENT
PREPARED BY:	D. Kerr <i>D Kerr</i>	7 Mar. 106	ECL ENGINEERING
PREPARED BY:			
CHECKED BY:	C. Timmins <i>C. Timmins</i>	7th March 2006	ECL ENGINEERING
CHECKED BY:	M. Merritt <i>M Merritt</i>	2006-03-07	ECL QUALITY ASSURANCE
APP'D / ACCEPTED (Civil A/W Authority)	(see TCCA stamp) <i>C. Timmins</i>	15th March 2006	ECL ENGINEERING
RELEASED BY:	B. Manson <i>B Manson</i>	20 Mar '06	ECL ENGINEERING



EUROCOPTER CANADA LIMITED

RECORD OF REVISIONS

Rev.	Pages at this revision	Description, Reason, Changed Pages	Prepared (name and date)	Checked (name and date)	App'd/Acc'd (Civil A/W Authority) (name and date)	Released (name and date)
0	1 through 8	Original issue	D. Kerr 10 June 2003	R. Manson 10 June 2003	TCCA Eric Cheung 11 June 2003	R. Manson 12 June 2003
1	1 through 31	Format revised. New Spectrolab parts incorporated. Weight and Balance data and wiring diagrams incorporated. inspection schedule expanded. SLASS System added. (Pages 5 to 31)	D. Kerr 27 Sept. 2005	C. Timmins 27 Sept. 2005	TCCA E. Cheung 8 Nov. 2005	R. Manson 8 Nov., 2005
2	1 through 31 A1 to A7	Life Limitations added, Spectrolab Safety and Service Bulletin added, drawing numbers removed from Weight and Balance chart. Wiring diagram titles revised. (Pages 8, 9, 10, 11, 12, 14, 15, 16, 17, 19 and Appendix A)	See page 1.	See page 1.	See page 1.	See page 1.

NOTE: Revisions to this document will be distributed to operators of this equipment by the STC holder.
NOTE: Revised portions of affected pages are identified by a vertical black line in the margin adjacent to the change.

Transport Canada Accepted

TC Accepted
MAR 14 2006

CONTENTS

SECTION	TITLE	PAGE
1.	GENERAL	5
2.	AIRWORTHINESS LIMITATIONS	8
3.	CONTROL AND OPERATION	9
4.	INSPECTION SCHEDULE AND MAINTENANCE ACTION	9
5.	OVERHAUL REQUIREMENTS	12
6.	TROUBLESHOOTING	12
7.	SPECIAL TOOLING	18
8.	REMOVAL AND REPLACEMENT	18
9.	WEIGHT AND BALANCE DATA	19
10.	PLACARDS AND MARKINGS	22
Appendix A	Spectrolab SX-16 Nightsun Searchlight Safety and Service Bulletin #SL 0899-01, Issued 08/25/99, (7 Pages)	

FIGURES

FIGURE	TITLE	PAGE
1	Spectrolab SX-16 Nightsun Searchlight Installation	6
2	Wiring Diagram for installation without Pilot's Cyclic Control	14
3	Wiring Diagram for installation with Pilot's Cyclic Control	15
4	Wiring Diagram for installation with SLASS	16
5	Wiring Diagram (Optional Mirror Control)	17
6	Spectrolab SX-16 Nightsun Searchlight Detachable Provisions	20
7	Spectrolab SX-16 Nightsun Searchlight Fixed Provisions	21
8	View showing label locations on Pilot's Cyclic Control for installation with Pilot's Cyclic Control	22
9	View showing label locations on Pilot's Cyclic Control for installation without Pilot's Cyclic Control	23
10	View showing label location on Hand Control Support Assembly for installation with/without Pilot's Cyclic Control	24
11	View showing label location on Hand Control Support Assembly for installation with SLASS	25

Transport Canada Accepted

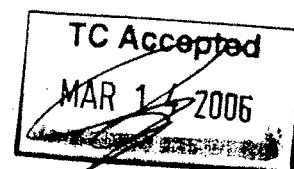



FIGURES (continued)

FIGURE	TITLE	PAGE
12	View showing label location on Cabin Floor with/without Pilot's Cyclic Control ...	26
13	View showing label location on Cabin Floor for installation with SLASS	27
14	View showing label location on Circuit Breaker Holder for installation with Spectrolab SX-16 Nightsun Searchlight	28
15	View showing label locations on Circuit Breaker Holder for installation with SLASS	29
16	View showing label location on Fuselage LHS for installation with Spectrolab SX-16 Nightsun Searchlight	30
17	View showing label location on Fuselage LHS for installation with SLASS	31

TABLES

TABLE	TITLE	PAGE
1	Inspection Schedule and Maintenance Action Before the first flight of each day	9
2	Inspection Schedule and Maintenance Action Every 100 flight hrs or 12 months, whichever occurs first	10
3	Inspection Schedule and Maintenance Action Every 400 flight hrs	11
4	Inspection Schedule and Maintenance Action Every 500 flight hrs or 24 months, whichever occurs first	11
5	Spectrolab SX-16 Nightsun Searchlight Troubleshooting	12
6	SLASS Troubleshooting	13

Transport Canada Accepted

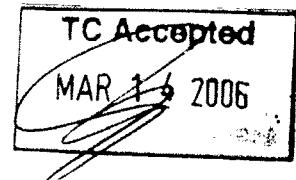

EUROCOPTER CANADA LIMITED

1. GENERAL

A. Introduction

The Spectrolab SX-16 Nightsun Searchlight is a high-intensity (20-30 million candlepower) searchlight mounted on the LH side of the helicopter. The searchlight is mounted with a dovetail assembly for quick installation and removal.

There are 5 variants to this installation:

Name of Assembly	Part No.
SX-16 Installation (with Pilot's Cyclic Control)	(drawing no.) 120-901234-01
SX-16 Installation (with Pilot's Cyclic Control)	(drawing no.) 120-901234-03
SX-16 Installation (without Pilot's Cyclic Control)	(drawing no.) 120-901234-02
SX-16 Installation (without Pilot's Cyclic Control)	(drawing no.) 120-901234-04
SLASS Integration with FLIR	(drawing no.) 120-901234-05

The installation with SLASS converts the Searchlight into a Slaved System which allows the Searchlight to follow in the same direction as the Electro-Optical FLIR Gimbal.

B. Description

The light can be controlled by any trained crewmember, excluding the pilot, by means of an external control box, or by the pilot using the cyclic stick control switches. Only one controller should be on at any time. The light is controllable from either station.

The installation with SLASS converts the hand controller to a manual Searchlight controller when the SLAVE switch is "OFF". The SLASS System is equipped with pilot and SX-16/SLASS operator directional and focus control for the Searchlight. Directional control priority is to the pilot, focus control has no priority.

It has a slew capability of approximately 100° in azimuth off of the LH side of the aircraft, and -10° to -70° in elevation from the horizon. The system is equipped with a circuit breaker and a fuse for system protection.

Installation, maintenance and flight limitations for the side-mounted searchlight are covered by FAA STC SR01302LA (Transport Canada accepted).

The Spectrolab SX-16 Nightsun Searchlight installation consists of the following main components:

- airframe mount with dovetail assembly for quick removal
- gimbal assembly with electrical actuators
- searchlight with xenon arc lamp, and cooling fan
- control box
- operator hand control and/or pilot's cyclic control
- SLASS Cables (if applicable)
- SLASS Electrical Control Unit (if applicable)

Transport Canada Accepted

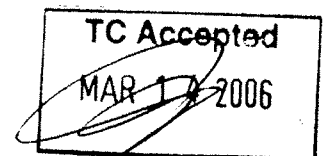

EUROCOPTER CANADA LIMITED

Technical Data

- Voltage : 28 VDC Nominal
- Lamp power output : 30,000,000 (Peak Beam Candle Power)
- Max. current consumption : 65 Amperes

For instructions on initial installation, see IP-ECL-108.

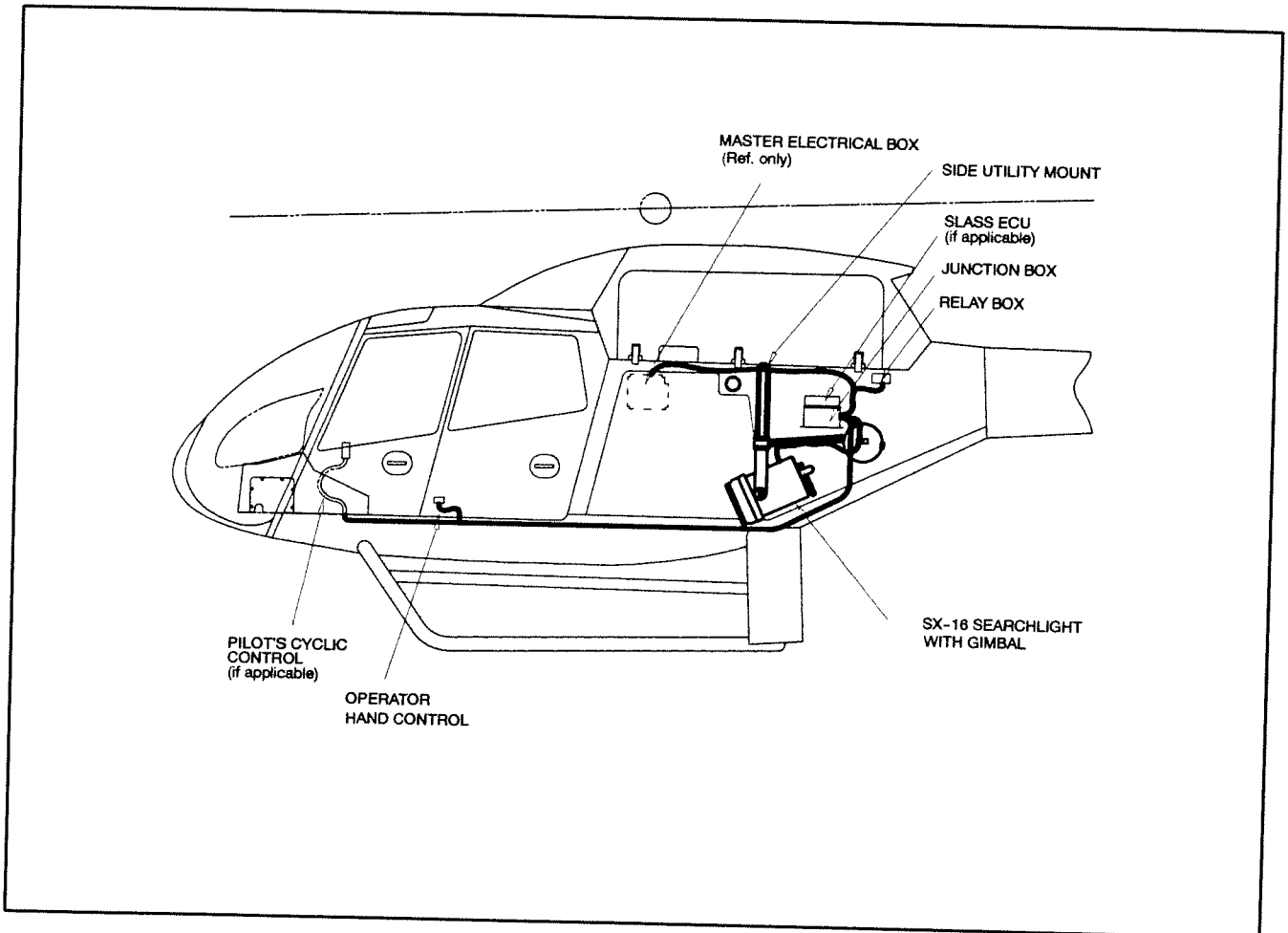
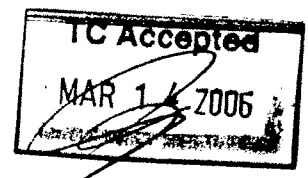

Figure 1 Spectrolab SX-16 Nightsun Searchlight Installation

Transport Canada Accepted



EUROCOPTER CANADA LIMITED

C. REFERENCES

DOCUMENT	DOCUMENT TITLE
MTC	Standard Practices Manual
AC 43.13	Advisory Circular No. 43.13-1B
MET	Maintenance Manual
IP-ECL-108	Installation Procedure, SX-16 Searchlight Installation Procedure

D. ABBREVIATIONS & DEFINITIONS

ABBREVIATION	DESCRIPTION
P/N	Part Number
EC	Eurocopter (France)
ECL	Eurocopter Canada Limited
FAA	Federal Aviation Administration
STC	Supplemental Type Certificate
LH	Left-Hand
RH	Right-Hand

E. UNITS OF MEASUREMENT

ABBREVIATION / SYMBOL	UNIT OF MEASUREMENT
kg	kilogram
lbs	pounds
m	meter
in	inch
m kg	meter kilogram
m daN	meter deca newton
±	plus-minus
°	degree
hrs	hours

Transport Canada Accepted

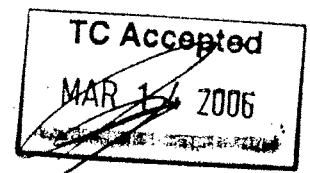

2. AIRWORTHINESS LIMITATIONS

The Airworthiness Limitations section is approved by the Minister and specifies maintenance required by any applicable airworthiness or operating rule unless an alternative program has been approved by the Minister.

There is a life limitation from the date of installation for the gimbal arm. Refer to Appendix A, page A7, paragraph 3.2.

Transport Canada Approved

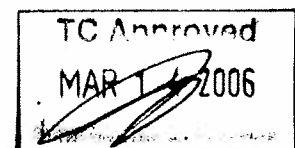

EUROCOPTER CANADA LIMITED

3. CONTROL AND OPERATION

Control and operation of the aircraft remains unchanged.

4. INSPECTION SCHEDULE AND MAINTENANCE ACTION

CAUTION: PRIOR TO WORKING ON THE SPECTROLAB SX-16 NIGHTSUN ENSURE THAT THE SEARCHLIGHT HAS COOLED.

NOTE Maintenance action is included for all variants. Disregard items specific to Pilot's Cyclic Control and SLASS for variants without those features.

For pre-flight check, refer to the appropriate manufacturer's instructions.

For the inspection schedule of A120-1 Universal Mount refer to "AIRFILM Camera Systems" (AF-120-005), Instructions for Continued Airworthiness.

For additional information on inspection and maintenance of the SX-16, refer to the "Spectrolab SX-16 Nightsun Searchlight" (031134), Operation and Maintenance Instructions.

For SX-16 Gimbal Inspection, Finish Touch-up Instructions and Life Limits, refer to Spectrolab SX-16 Nightsun Searchlight Safety and Service Bulletin #SL 0899-01 located in Appendix A.

4.1. INSPECTION SCHEDULE

4.1.1. Before the first flight of each day:

Use torque per EC, MTC, Volume 2, Chapter 20.02.05.404, unless otherwise specified.

ITEM	INSPECTION OR MAINTENANCE WORK	CORRECTIVE ACTION
A	<ul style="list-style-type: none"> - Visually inspect Searchlight, item 2, and Gimbal, item 1, in Figure 6, mounting brackets and retaining components for: <ul style="list-style-type: none"> a. security b. general condition of hardware 	<ul style="list-style-type: none"> a. Check security by performing a shake test by hand, refer to Spectrolab Operation and Maintenance Instructions. b. If hardware is damaged or corrosion is found, refer to Spectrolab Operation and Maintenance Instructions.
B	<ul style="list-style-type: none"> Inspect gimbal clutches for: <ul style="list-style-type: none"> a. feel b. excessive wear (slipped clutch, worn gears) 	<ul style="list-style-type: none"> a. Carefully move Searchlight by hand to cause the azimuth and elevation clutches to slip. b. No excessive wear is permitted, if excessive wear is evident, refer to the Spectrolab Operation and Maintenance Instructions.

Table 1 Inspection Schedule and Maintenance Action
Before the first flight of each day
(continued on following page)

Transport Canada Accepted

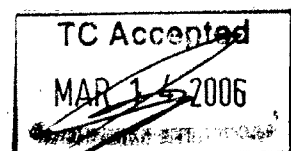

EUROCOPTER CANADA LIMITED

4.1. INSPECTION SCHEDULE (continued)

4.1.1. Before the first flight of each day: (continued)

ITEM	INSPECTION OR MAINTENANCE WORK	CORRECTIVE ACTION
C	- Visually inspect Lower Dovetail Aligning Plate, item 8, in Figure 6 for: a. security	a. Secure as required.
D	- Visually inspect electrical plug connections for: a. security b. cracking and fraying	a. Secure as required. b. No cracking or fraying is allowed, if cracking or fraying is found, refer to Spectrolab Operation and Maintenance Instructions.
E	- Visually inspect cables for: a. excessive wear (scoring, area have become worn, grease or oil deposits) b. corrosion	a. Excessive wear is not permitted. If excessive wear is evident, contact Spectrolab. b. No corrosion is allowed, if corrosion is found contact Spectrolab.
F	- Visually inspect SX-16 front window, item 4, reflector, item 5 and fan, item 6 in Figure 6 for: a. obstructions (ensure Searchlight has cooled)	a. Remove any residue. Refer to Spectrolab Operation and Maintenance Manual before cleaning.

Table 1 Inspection Schedule and Maintenance Action
Before the first flight of each day

4.1.2. Every 100 flight hrs or 12 months (to coincide with the 100 hrs or 12 month helicopter inspection), whichever occurs first:

ITEM	INSPECTION OR MAINTENANCE WORK	CORRECTIVE ACTION
A	- Visually inspect end plate, item 3, in Figure 6 for: a. cracks around suspension bolt holes	a. If cracking is found, contact Spectrolab.
B	- Visually inspect webbing, item 3 on hand control support assembly, item 2, in Figure 7 for: a. wear (tears, areas have become worn) b. security	a. Wear is not permitted. If wear is evident, replace webbing. b. Secure button snap as required.

Table 2 Inspection Schedule and Maintenance Action
Every 100 flight hrs or 12 months, whichever occurs first
(continued on following page)

Transport Canada Accepted

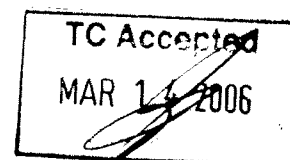

EUROCOPTER CANADA LIMITED

4.1. INSPECTION SCHEDULE (continued)

4.1.3. Every 100 flight hrs or 12 months (to coincide with the 100 hrs or 12 month helicopter inspection), whichever occurs first (continued):

ITEM	INSPECTION OR MAINTENANCE WORK	CORRECTIVE ACTION
C	<ul style="list-style-type: none"> - Check placards for: <ul style="list-style-type: none"> a. legibility b. secure mounting of Placards and Markings (refer to Section 10 in this document) 	<ul style="list-style-type: none"> a. If placards have become illegible, contact ECL for replacement parts. (refer to IP-ECL-104 for placard part numbers) b. Secure, reattach placards as required

Table 2 Inspection Schedule and Maintenance Action
Every 100 flight hrs or 12 months, whichever occurs first

4.1.4. Every 400 flight hrs:

ITEM	INSPECTION OR MAINTENANCE WORK	CORRECTIVE ACTION
A	<ul style="list-style-type: none"> - Visually inspect blower brushes for: <ul style="list-style-type: none"> a. correct operation (ensure Searchlight has cooled) 	<ul style="list-style-type: none"> a. Refer to the Spectrolab Operation and Maintenance Instructions manual.

Table 3 Inspection Schedule and Maintenance Action
Every 400 flight hrs

4.1.5. Every 500 flight hrs or 24 months, whichever occurs first:

ITEM	INSPECTION OR MAINTENANCE WORK	CORRECTIVE ACTION
A	<ul style="list-style-type: none"> - Visually inspect junction box for: <ul style="list-style-type: none"> a. moisture and dust b. burnt wires c. secure connections 	<ul style="list-style-type: none"> a. Remove cover and carefully clean unit. b. Replace wires as required c. Secure as required

Table 4 Inspection Schedule and Maintenance Action
Every 500 flight hrs or 24 months, whichever occurs first

4.1.6. **NOTE** Specific gimbal inspection intervals are contained in Appendix A, page A3, in SUMMARY paragraph.

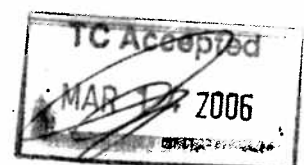

EUROCOPTER CANADA LIMITED

5. OVERHAUL REQUIREMENTS

No overhaul requirements for this installation.

6. TROUBLESHOOTING

For electrical system troubleshooting, refer to Figures 2, 3 and 4, Wiring Diagrams.

NOTE Troubleshooting is included for all variants. Disregard items specific to Pilot's Cyclic Control and SLASS for variants without those features.

For additional information on troubleshooting the SLASS refer to "Universal Searchlights" Operation and Installation Manual for the Model S-301 Slaved Searchlight System (SLASS) with SLASS-ECU. Spectrolab SX-16 Nightsun Searchlight troubleshooting:

ITEM	TROUBLE / SYMPTOM	PROBABLE CAUSE	CORRECTIVE ACTION
1	Lamp does not start from Operator Hand Control or Pilot's Cyclic Control (if applicable)	Bulb burnt out.	Replace bulb in accordance with Spectrolab SX-16 Nightsun Operations & Maintenance Manual included with the Searchlight.
		Junction Box Defective	Remove and replace with a serviceable unit or contact Spectrolab, Inc. for troubleshooting.
		Searchlight defective	Remove and replace with a serviceable unit or contact Spectrolab, Inc. for troubleshooting.
		Pilot's Cyclic Control (if applicable) Relay Panel Defective	Remove and replace with a serviceable unit or contact ECL for detailed troubleshooting.
2	Gimbal does not respond to Operator Hand Control or Pilot's Cyclic Control (if applicable)	Junction Box Defective	Remove and replace with a serviceable unit or contact Spectrolab, Inc. for troubleshooting.
		Gimbal Defective	Remove and replace with a serviceable unit or contact Spectrolab, Inc. for troubleshooting.
		Pilot's Cyclic Control (if applicable) Relay Panel Defective	Remove and replace with a serviceable unit or contact ECL for detailed troubleshooting.
3	Lamp does not start, or Gimbal does not respond to Operator Hand Control, starts or responds to Pilot's Cyclic Control (if applicable).	Operator Hand Control Defective	Remove and replace with a serviceable unit or contact Spectrolab, Inc. for troubleshooting.

Table 5 Spectrolab SX-16 Nightsun Searchlight Troubleshooting Guide
(continued on following page)

Transport Canada Accepted

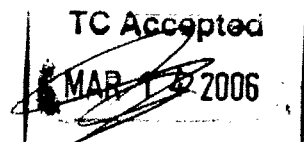

EUROCOPTER CANADA LIMITED

6. TROUBLESHOOTING (continued)

Spectrolab SX-16 Searchlight troubleshooting (continued):

ITEM	TROUBLE / SYMPTOM	PROBABLE CAUSE	CORRECTIVE ACTION
4	Lamp does not start, or Gimbal does not respond to the Pilot's Cyclic Control (if applicable), starts or responds to Operator Hand Controller	Pilot's Cyclic Control (if applicable) Defective	Remove and replace with a serviceable unit or contact ECL for detailed troubleshooting.

Table 5 Spectrolab SX-16 Nightsun Searchlight Troubleshooting Guide

SLASS troubleshooting:

ITEM	TROUBLE / SYMPTOM	PROBABLE CAUSE	CORRECTIVE ACTION
1	SLASS works in manual mode, but will not Slave	Loose FLIR cable or connector	Check cables and connections or contact Universal Searchlights for detailed troubleshooting.
2	System does not work but works with SLASS Adapter/Test Box	Damaged ECU control card	Contact Universal Searchlights for corrective action

Table 6 SLASS Troubleshooting Guide

Transport Canada Accepted

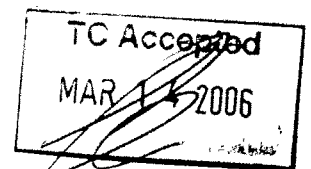

EUROCOPTER CANADA LIMITED

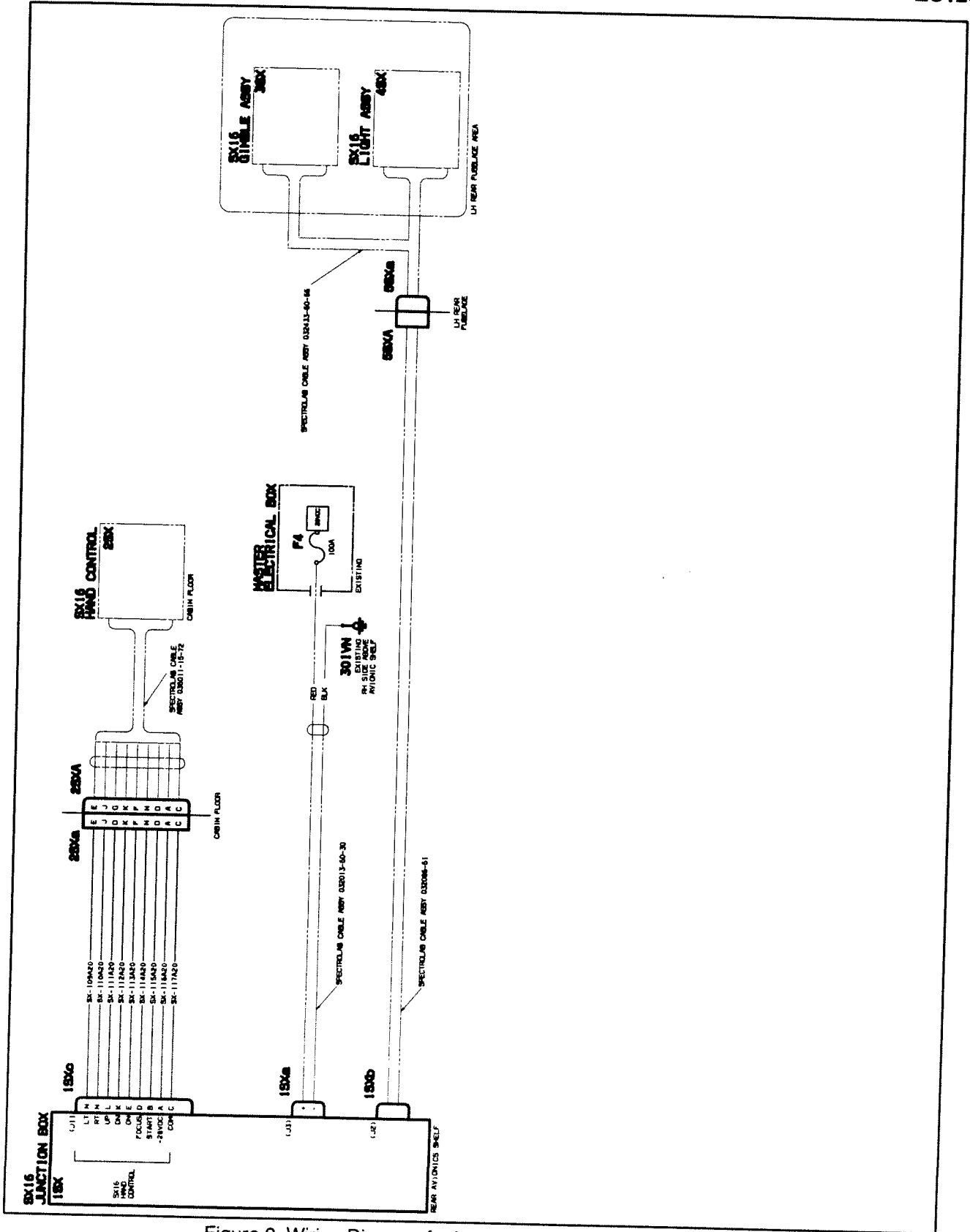

Figure 2 Wiring Diagram for installation without Pilot's Cyclic Control

Transport Canada Accepted

TC Accepted
MAR 1 2006



EUROCOPTER CANADA LIMITED

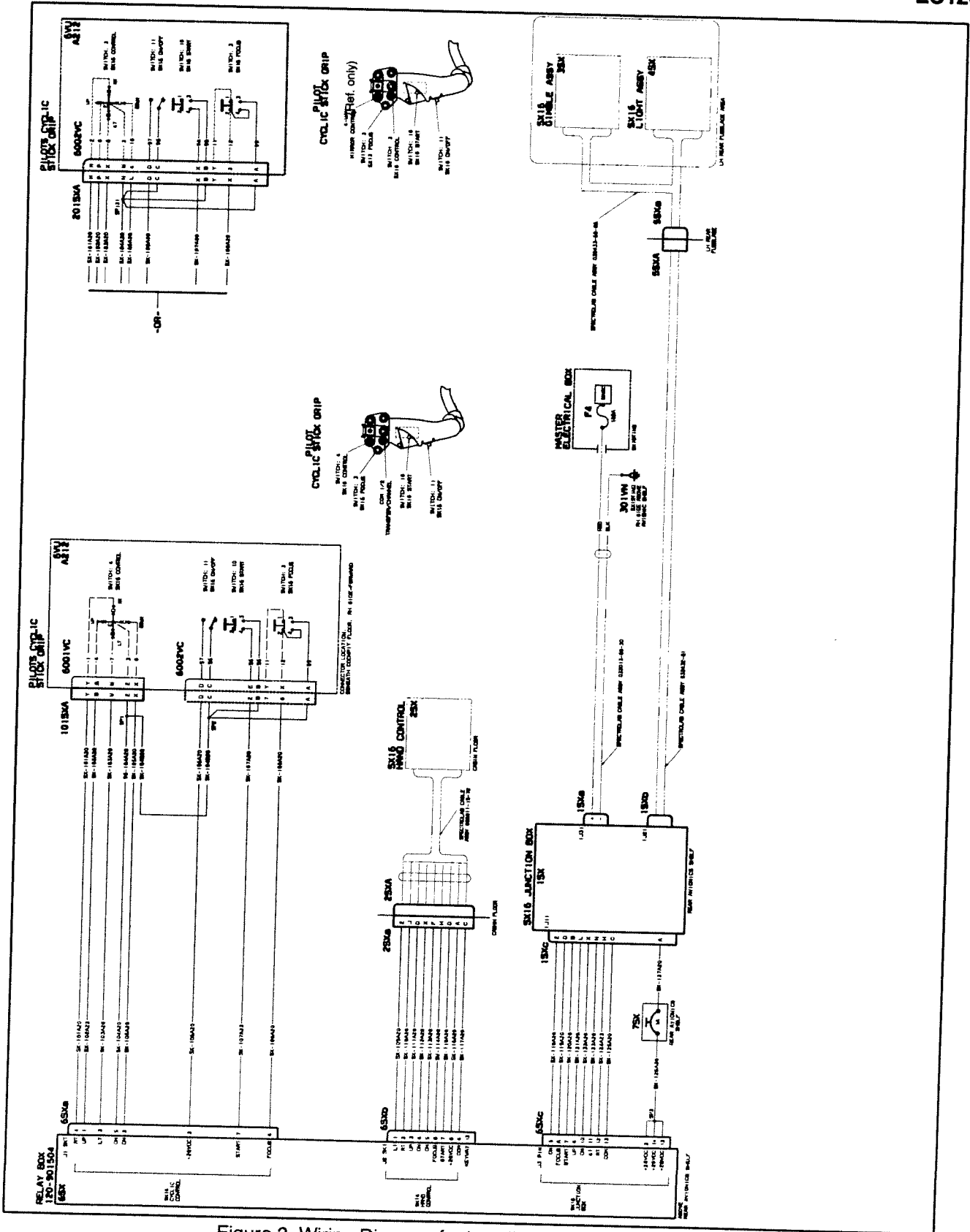

Figure 3 Wiring Diagram for installation with Pilot's Cyclic Control

Transport Canada Accepted

TC Accepted
MAR 14 2006

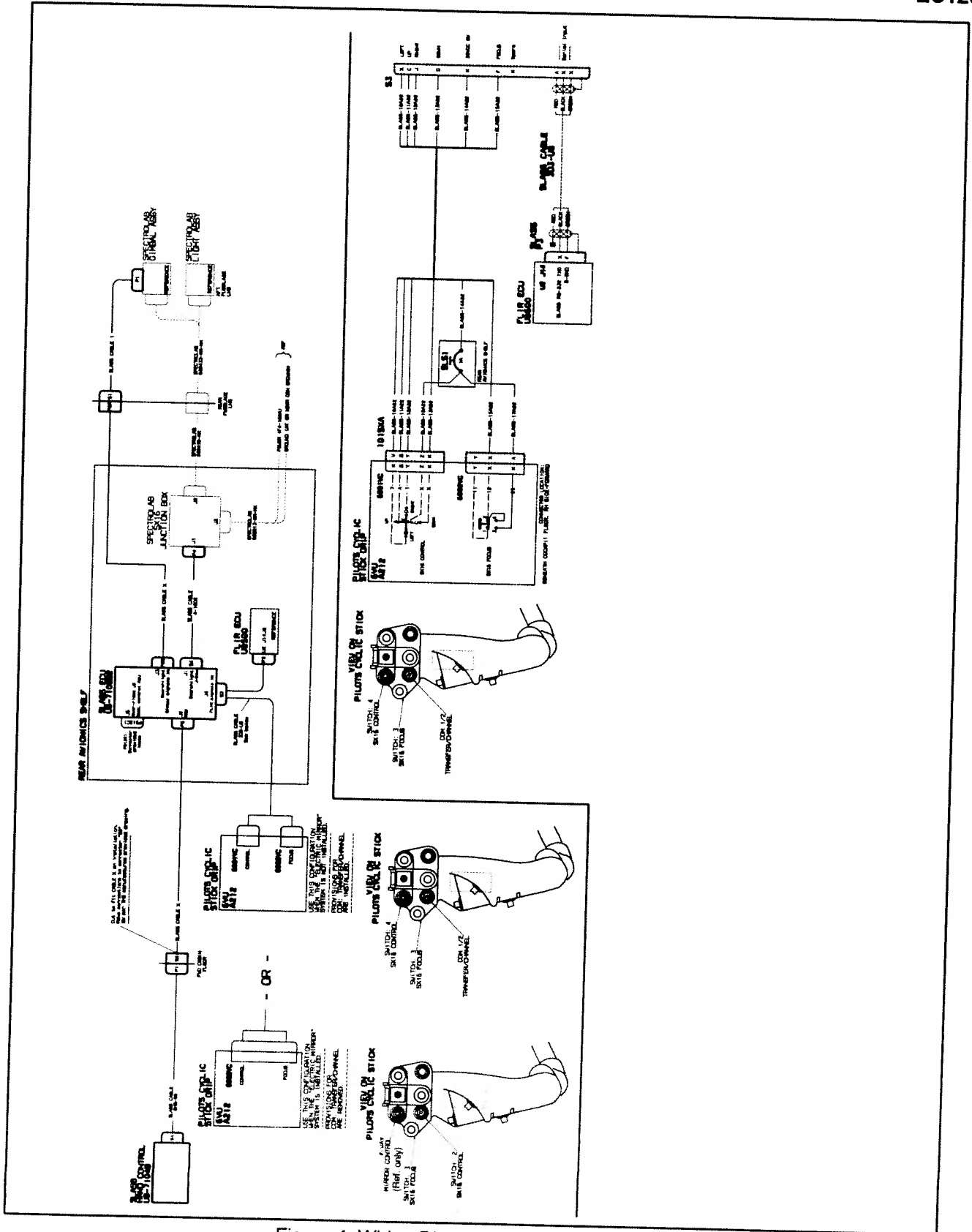
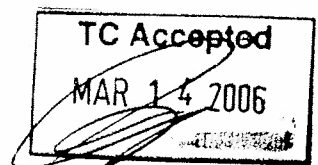

Figure 4 Wiring Diagram for installation with SLASS

Transport Canada Accepted



EUROCOPTER CANADA LIMITED

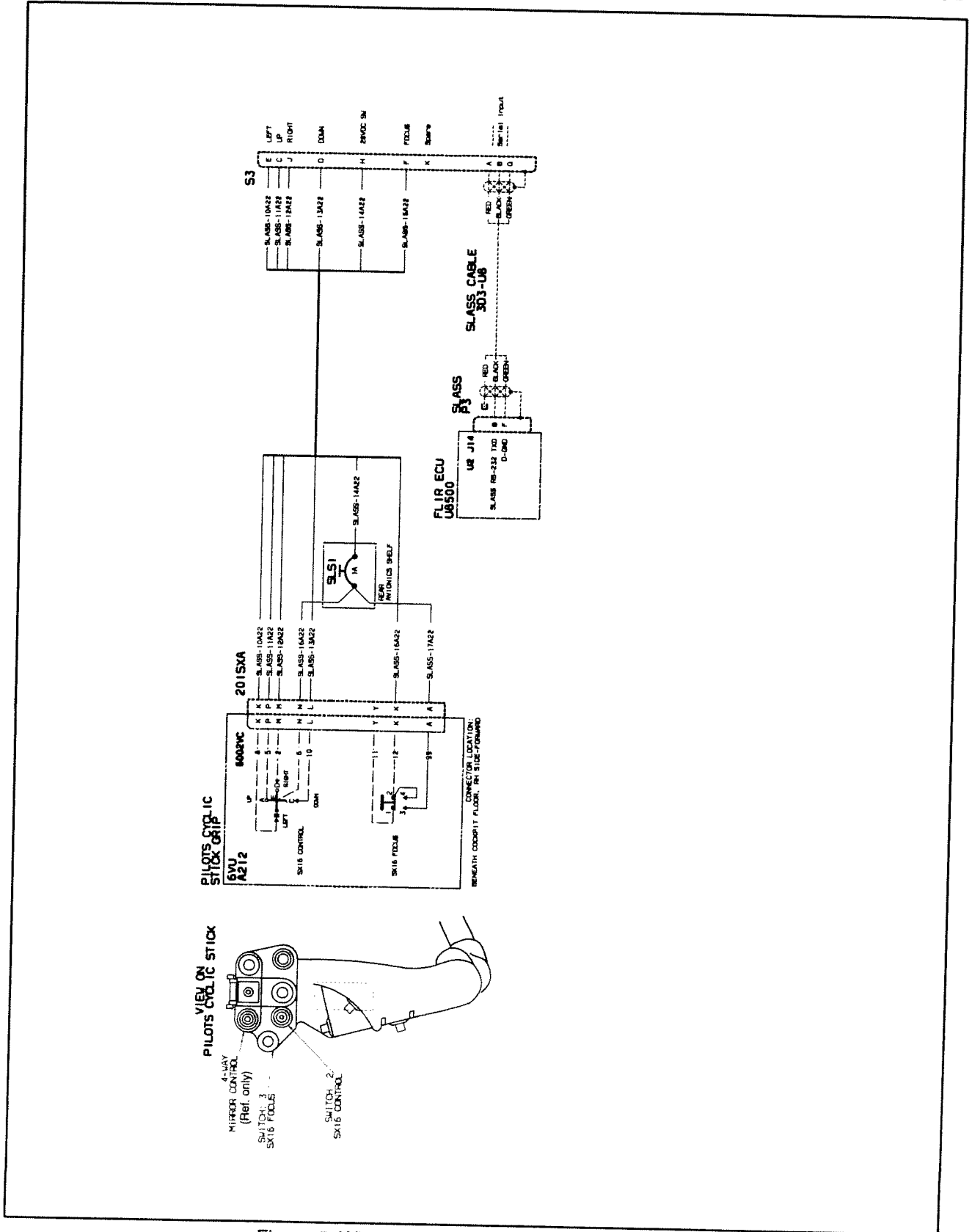

Figure 5 Wiring Diagram (Optional Mirror Control)

Transport Canada Accepted

TC Accepted
MAR 14 2006

EUROCOPTER CANADA LIMITED

7. SPECIAL TOOLING

No special tools are required. Standard tools are adequate.

The SLASS Adapter/Test Box is used when the FLIR and SLASS ECU are removed from the aircraft to manually operate the Searchlight and SLASS RCU.

8. REMOVAL AND REPLACEMENT

Proceed as follows if any of these items need to be removed.

Refer to Figure 6 for component removal and replacement.

A. REMOVAL

- 1) Spectrolab SX-16 Nightsun Searchlight (Refer to Figure 6)
 - a) Remove connector (9) from socket on LHS of aircraft.
 - b) Remove pin (10, 1 place) and loosen clamps (11, 2 places).
 - c) Slide lower dovetail aligning plate (8) out of the upper dovetail aligning plate.
- 2) Universal Mount
 - a) For information on the removal of the A120-1 Universal Mount refer to "AIRFILM Camera Systems" A120-1 UNIVERSAL MOUNT (AF120 005), Instructions for Continued Airworthiness.
- 3) SLASS
 - a) For information on the removal of the SLASS refer to "Universal Searchlights" Operation and Installation Manual for the Model S-301 Slaved Searchlight System (SLASS) with SLASS-ECU.

B. REPLACEMENT

- 1) Spectrolab SX-16 Nightsun Searchlight (Refer to Figure 6)
 - a) Slide lower dovetail aligning plate (8) into the upper dovetail aligning plate.
 - b) Tighten clamps (11, 2 places) and secure using pin (10, 1 place).
 - c) Secure connector (9) to LHS of aircraft.
- 2) Universal Mount
 - a) For information on the installation of the A120-1 Universal Mount refer to "AIRFILM Camera Systems" (AF-120-005), Instructions for Continued Airworthiness.
- 3) SLASS
 - a) For information on the installation of the SLASS refer to "Universal Searchlights" Operation and Installation Manual for the Model S-301 Slaved Searchlight System (SLASS) with SLASS-ECU..

Transport Canada Accepted

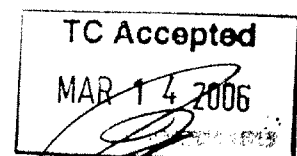

EUROCOPTER CANADA LIMITED

9. WEIGHT AND BALANCE DATA

A. Weight and Balance of Components Installed

DESCRIPTION	WEIGHT		ARM		MOMENT	
	kg	lbs	m	in	kg m	lb in
*Searchlight	19.20	42.3	4.66	183.5	89.47	7762.1
*Utility Mount	9.77	21.5	4.66	183.5	45.53	3945.3
Hand Controller	0.28	0.6	2.80	110.2	0.78	66.1
Relay Box	0.50	1.1	5.21	205.1	2.61	225.6
Junction Box	2.96	6.5	4.90	192.8	14.49	1253.2
Shelf Reinforcement	0.59	1.3	4.91	193.4	2.92	251.4

* AIRFILM MODEL AF-120 LEFT SIDE UTILITY MOUNT STC SR01302LA

B. Weight and Balance of Components Removed

Not applicable						
----------------	--	--	--	--	--	--

Transport Canada Accepted

TC Accepted
MAR 14 2006

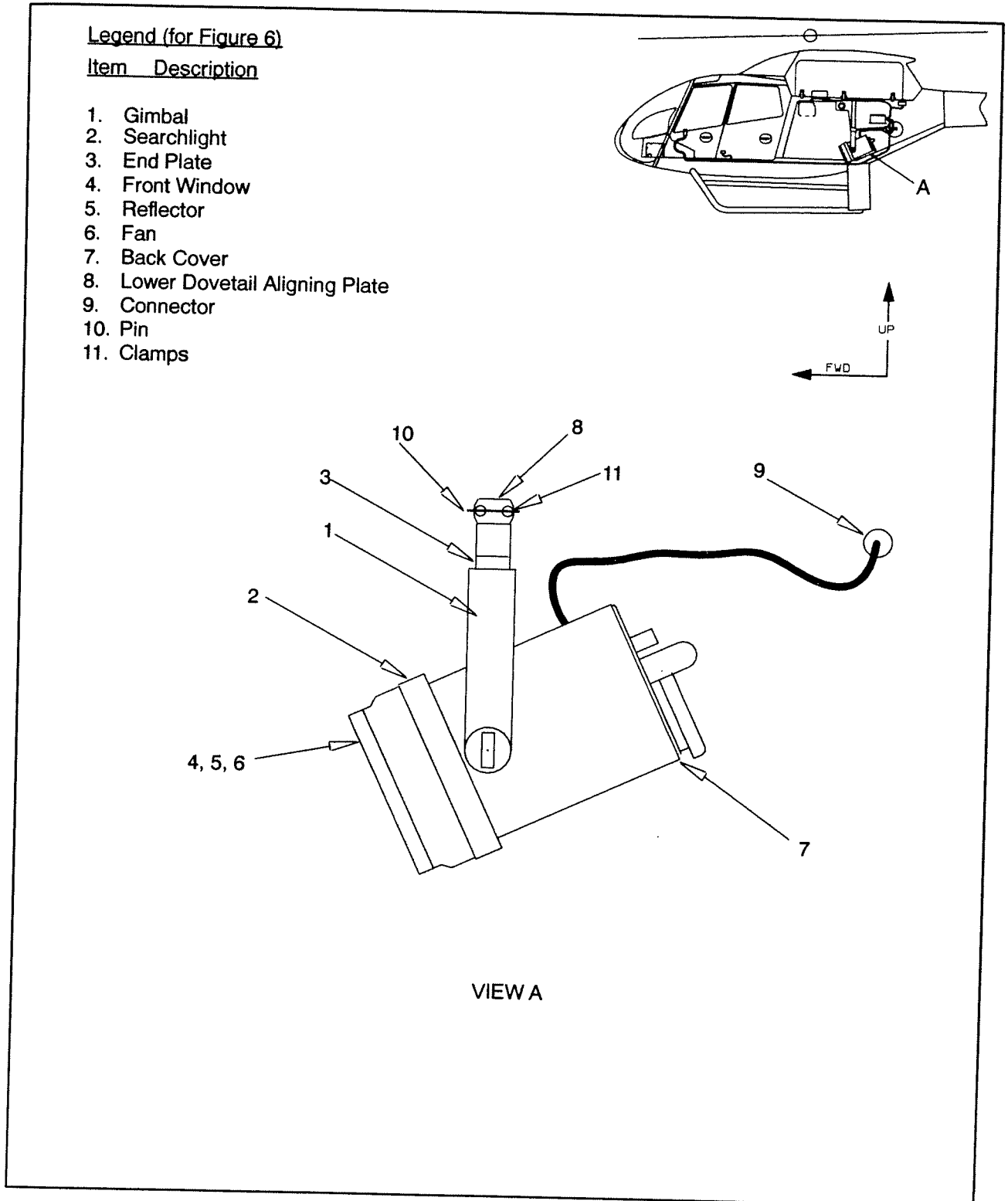
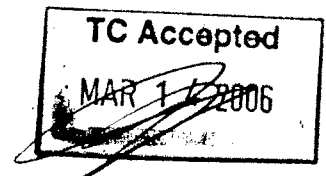

Figure 6 Spectrolab SX-16 Nightsun Searchlight Details

Transport Canada Accepted





Legend (for Figure 7)

Item Description

- 1. Operator Hand Control
- 2. Hand Control Support Assembly
- 3. Webbing

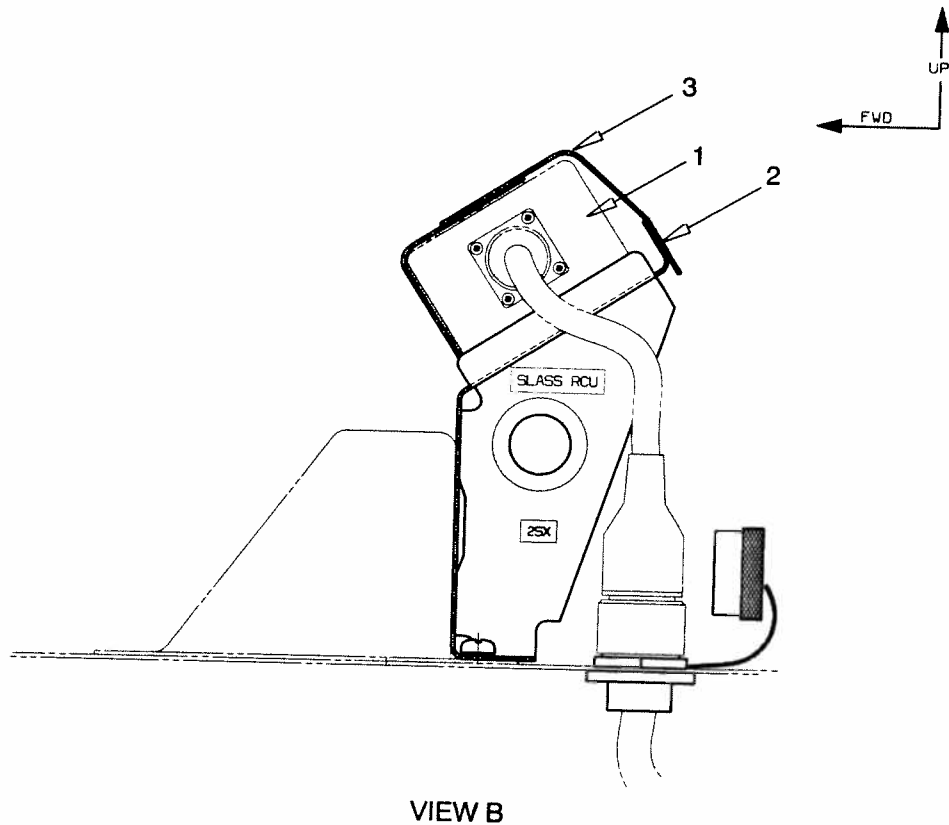
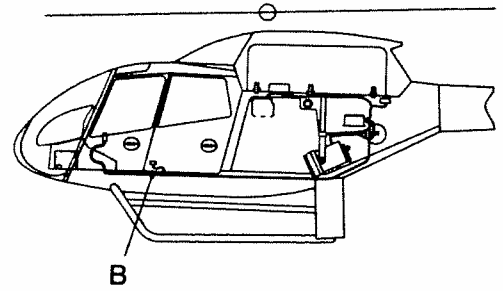
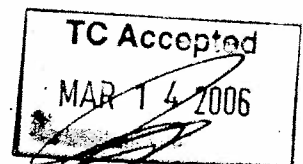

Figure 7 Hand Control Support Assembly Details

Transport Canada Accepted



EUROCOPTER CANADA LIMITED

10. PLACARDS AND MARKINGS

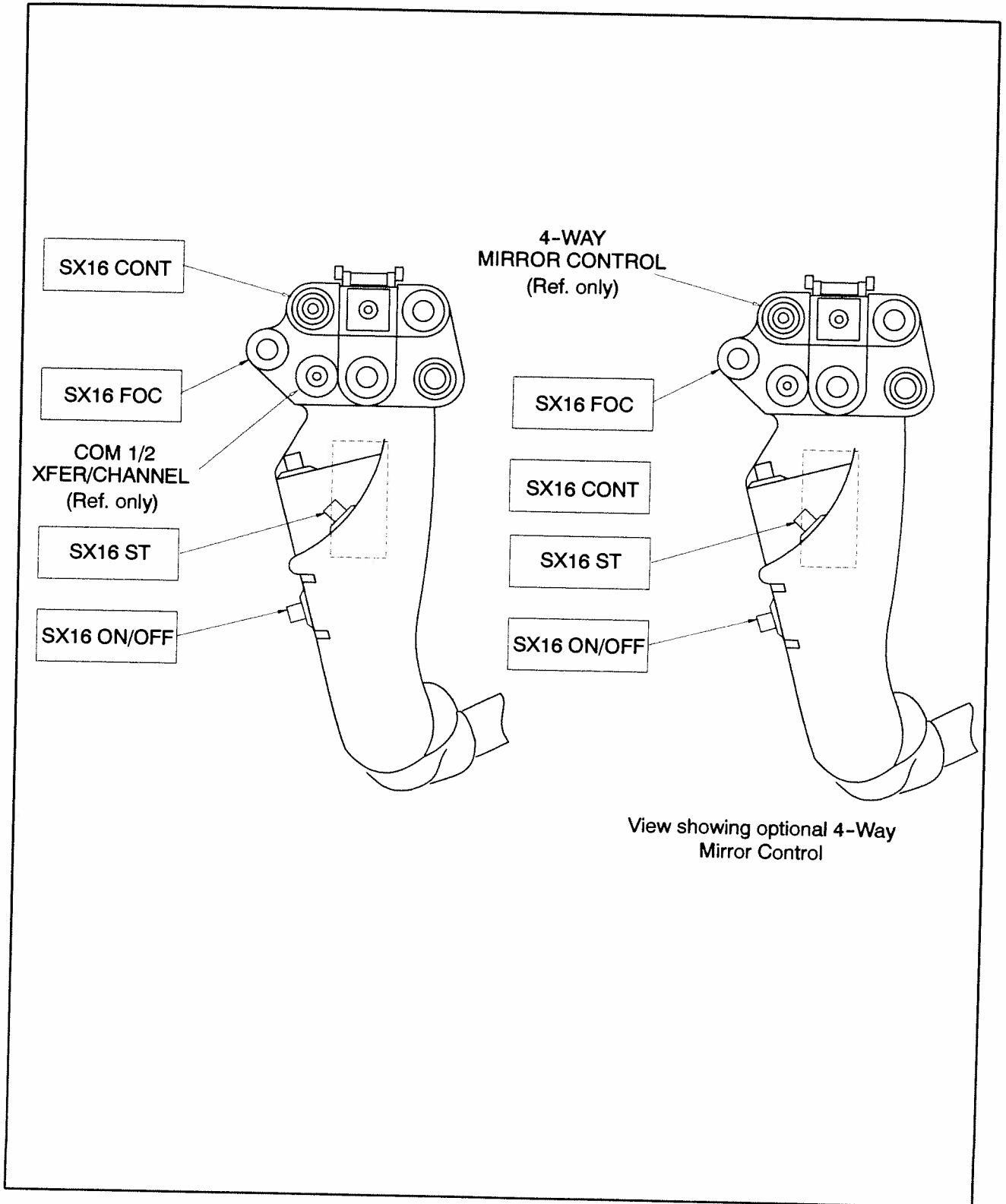

View showing optional 4-Way
Mirror Control

Figure 8 View showing label locations on Pilot's Cyclic Control
for installation with Pilot's Cyclic Control

Transport Canada Accepted

TC Accepted
MAR 14 2006

EUROCOPTER CANADA LIMITED

10 PLACARDS AND MARKINGS (continued)

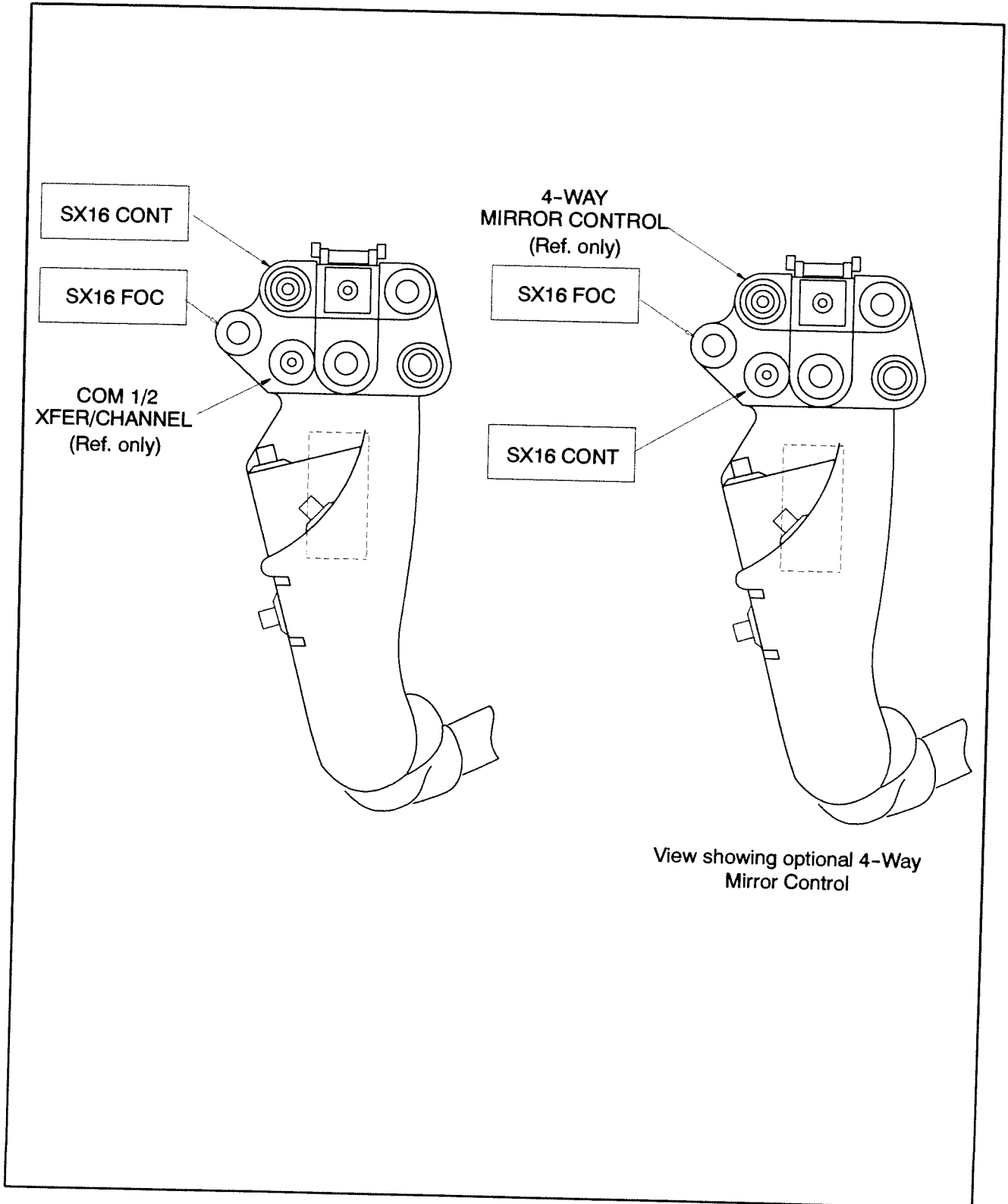
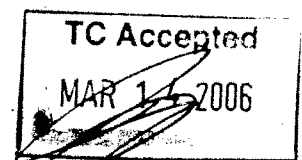

Figure 9 View showing label locations on Pilot's Cyclic Control for installation with SLASS

Transport Canada Accepted



EUROCOPTER CANADA LIMITED

10. PLACARDS AND MARKINGS (continued)

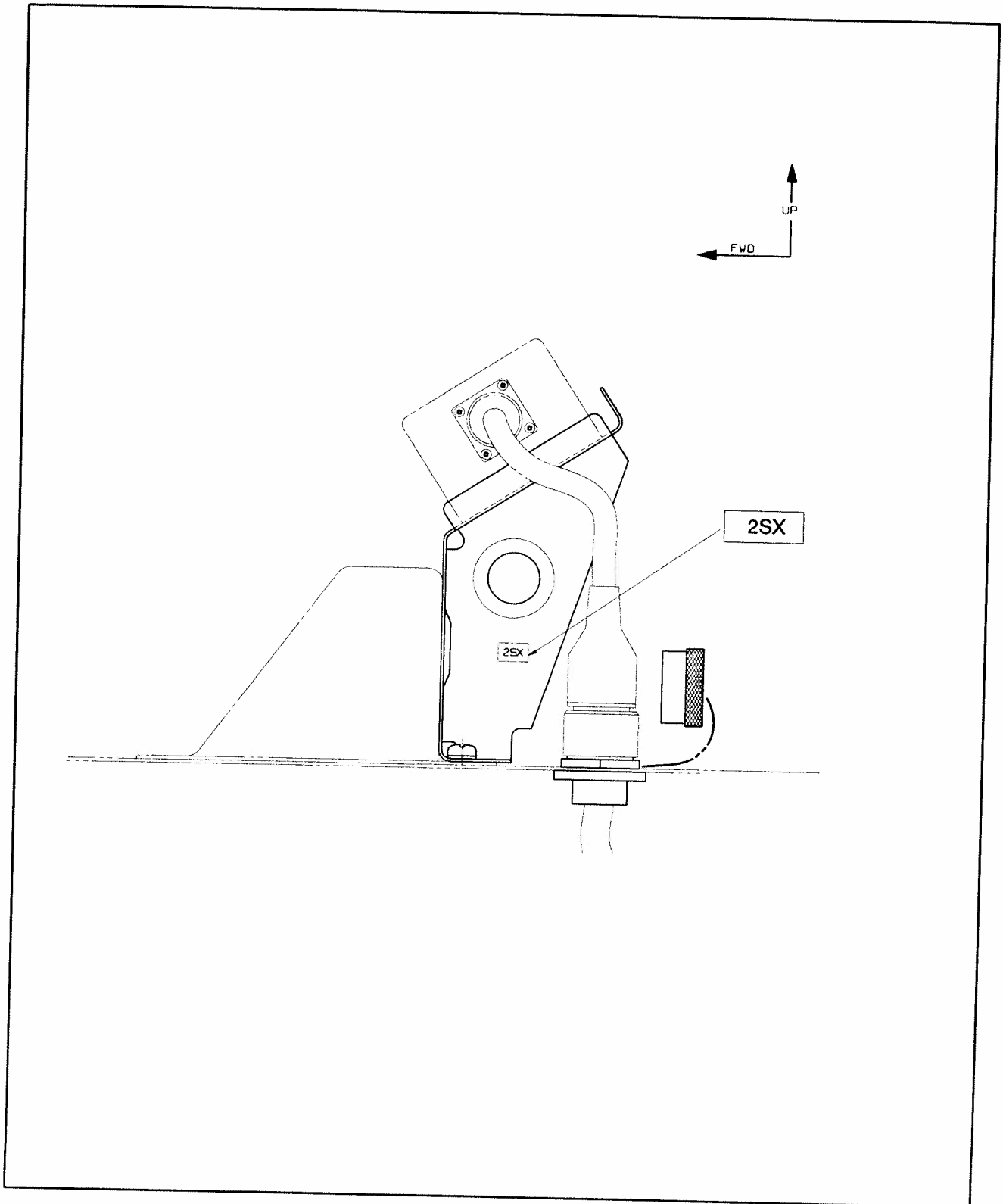

Figure 10 View showing label location on Hand Control Support Assembly for installation with/without Pilot's Cyclic Control

Transport Canada Accepted

TC Accepted
MAR 14 2006

EUROCOPTER CANADA LIMITED

10. PLACARDS AND MARKINGS (continued)

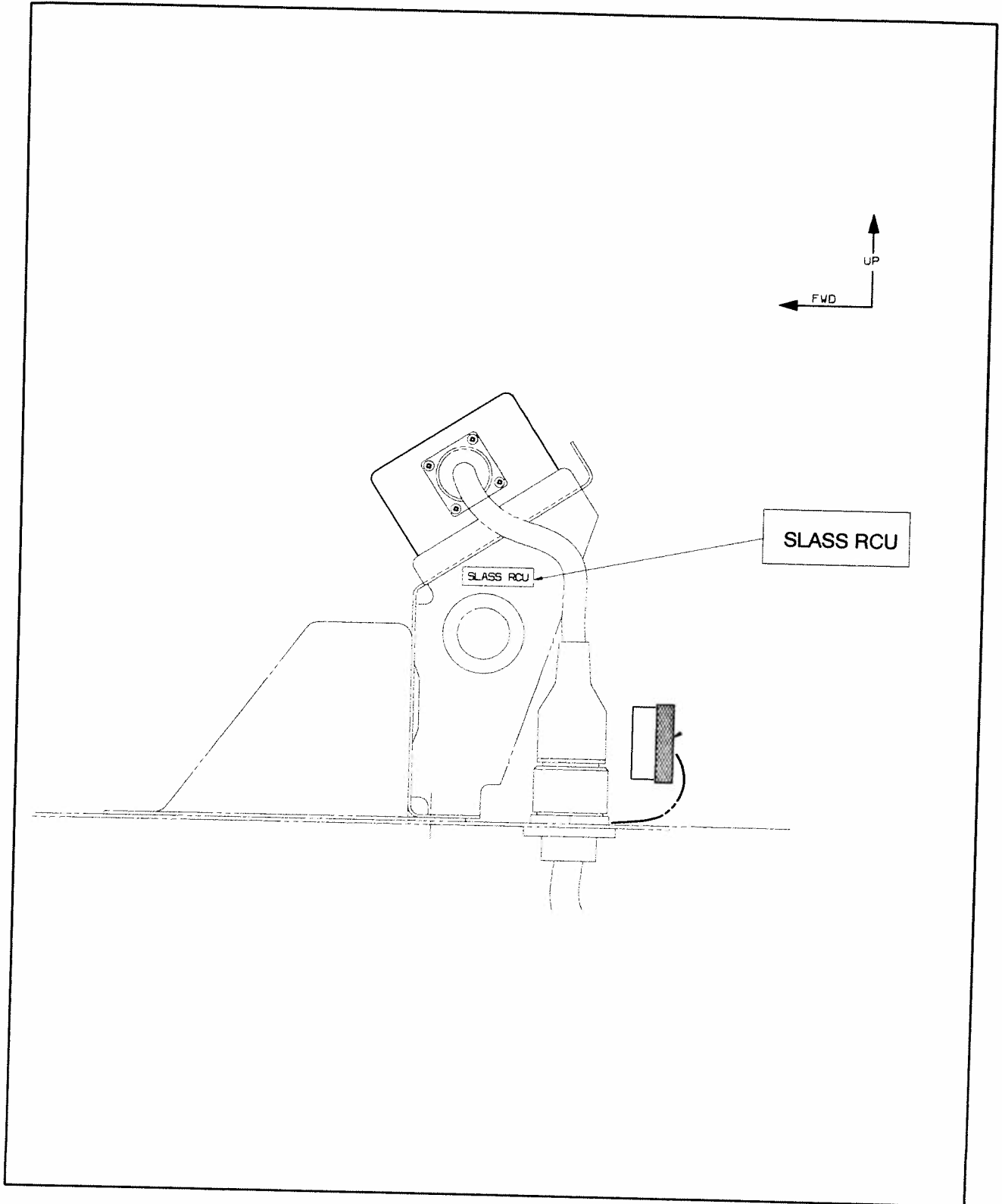

Figure 11 View showing label location on Hand Control Support Assembly for installation with SLASS

Transport Canada Accepted

TC Accepted
MAR 1 2006

EUROCOPTER CANADA LIMITED

10. PLACARDS AND MARKINGS (continued)

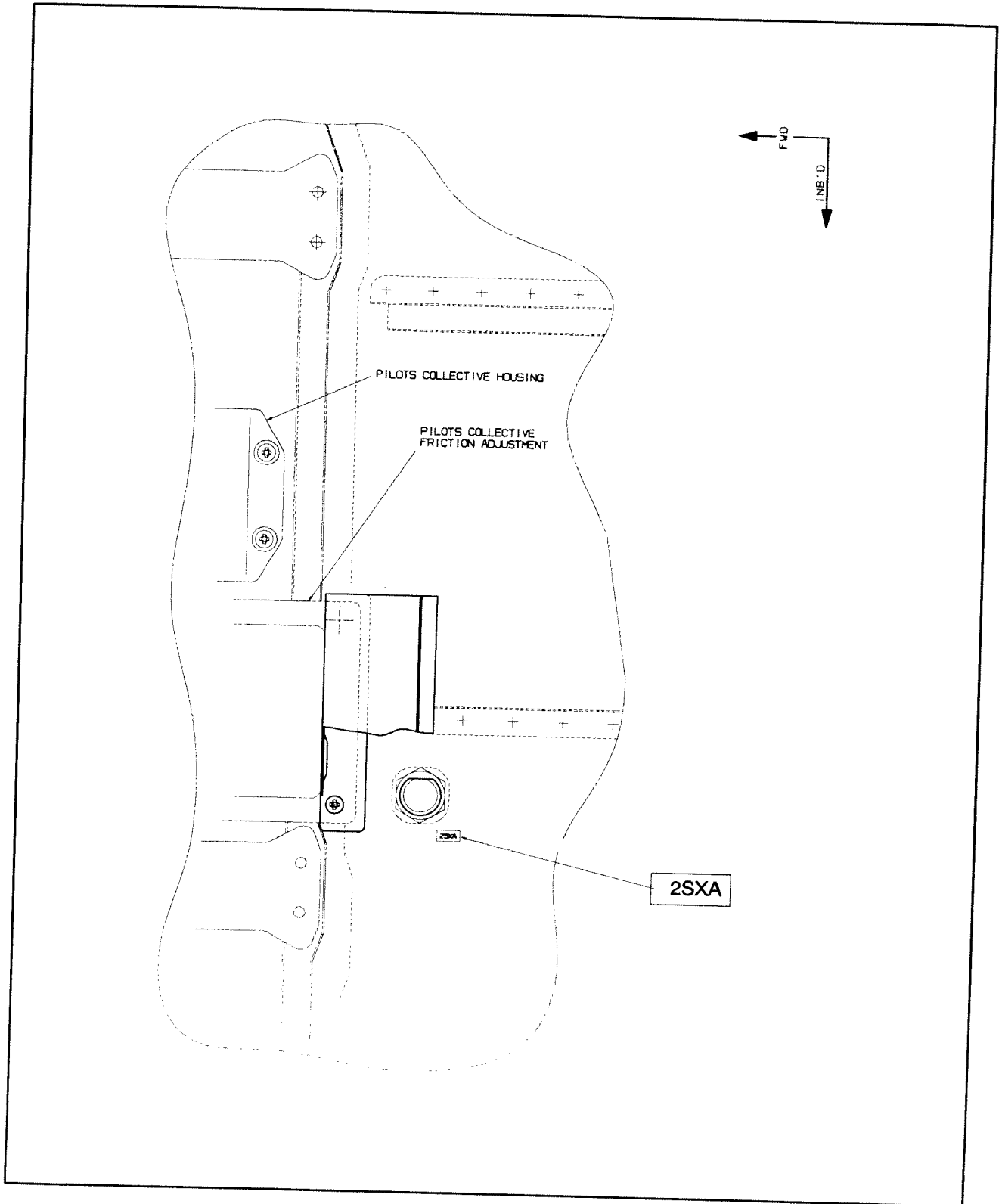

Figure 12 View showing label location on Cabin Floor with/without Pilot's Cyclic Control

Transport Canada Accepted

TC Accepted
MAR 1 2006

EUROCOPTER CANADA LIMITED

10. PLACARDS AND MARKINGS (continued)

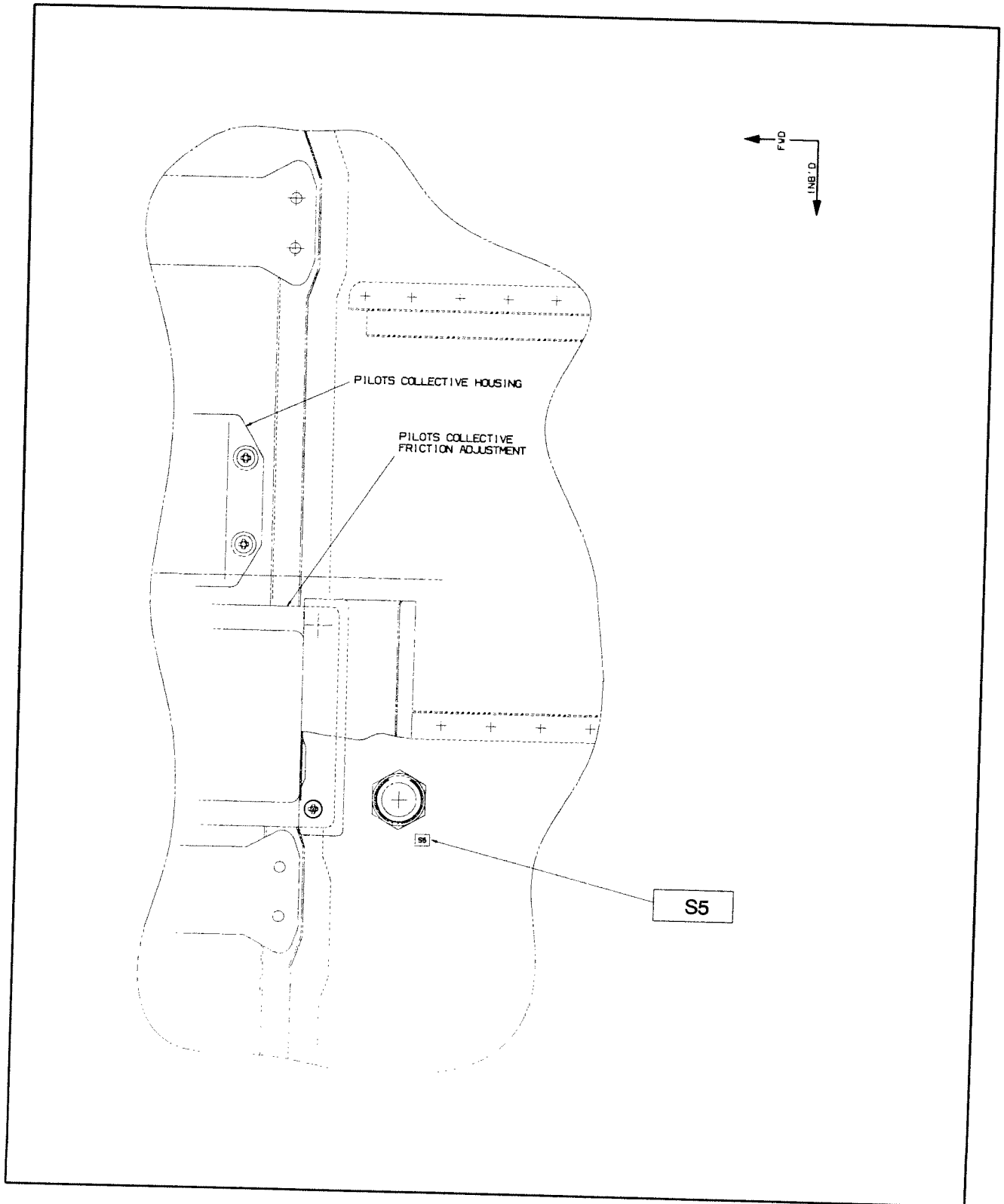

Figure 13 View showing label location on Cabin Floor for installation with SLASS

Transport Canada Accepted

TC Accepted
MAR 13 2006

EUROCOPTER CANADA LIMITED

10. PLACARDS AND MARKINGS (continued)

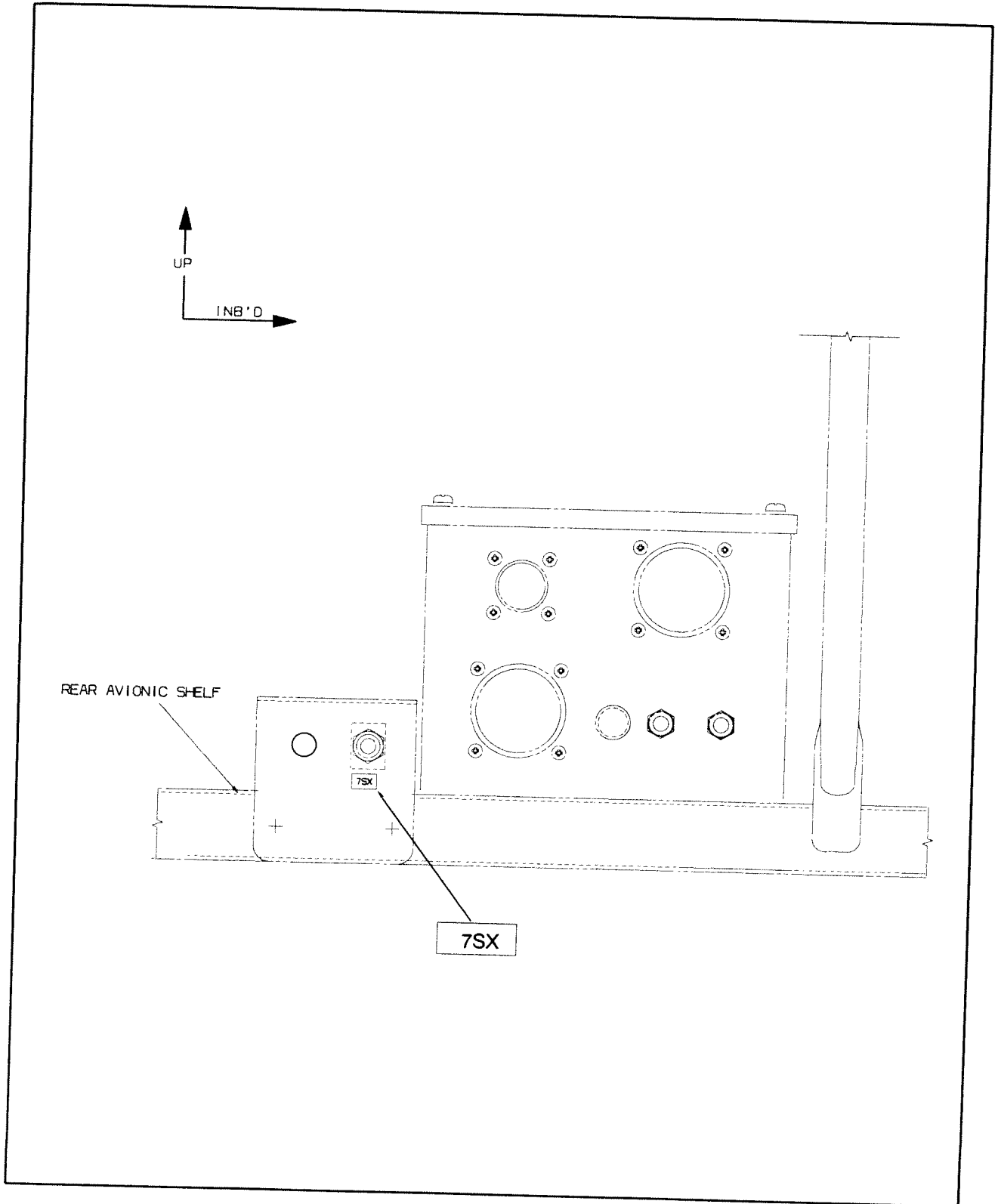

Figure 14 View showing label location on Circuit Breaker Holder for installation with Spectrolab SX-16 Nightsun Searchlight

Transport Canada Accepted

TC Accepted
MAR 14 2006

EUROCOPTER CANADA LIMITED

10. PLACARDS AND MARKINGS (continued)

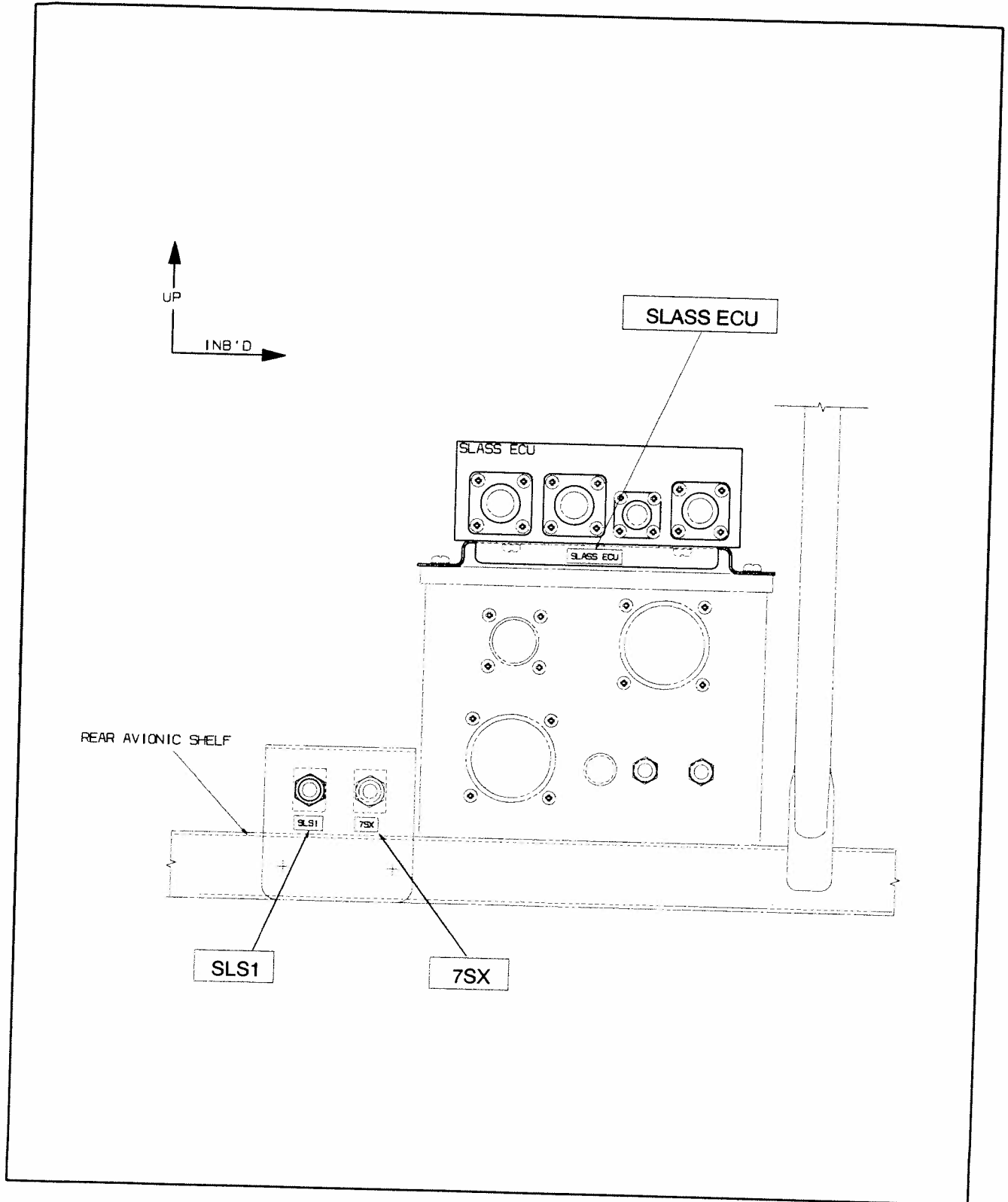
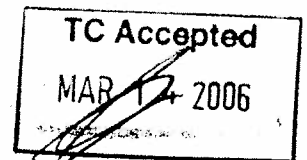

Figure 15 View showing label location on Circuit Breaker Holder for installation with SLASS

Transport Canada Accepted



EUROCOPTER CANADA LIMITED

10. PLACARDS AND MARKINGS (continued)

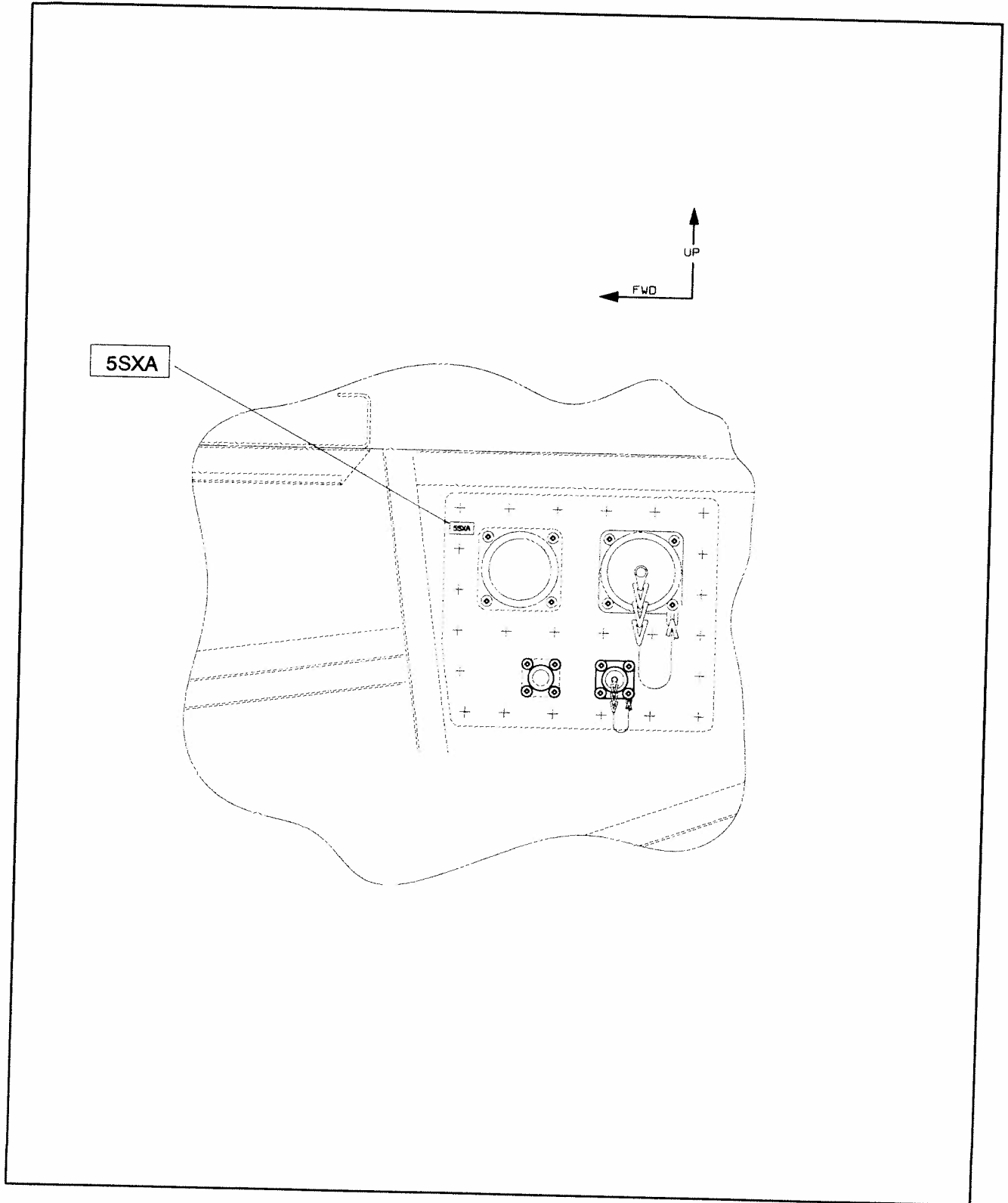

Figure 16 View showing label location on Fuselage LHS
for installation with Spectrolab SX-16 Nightsun Searchlight

Transport Canada Accepted

TC Accepted
MAR 14 2006

EUROCOPTER CANADA LIMITED

10. PLACARDS AND MARKINGS

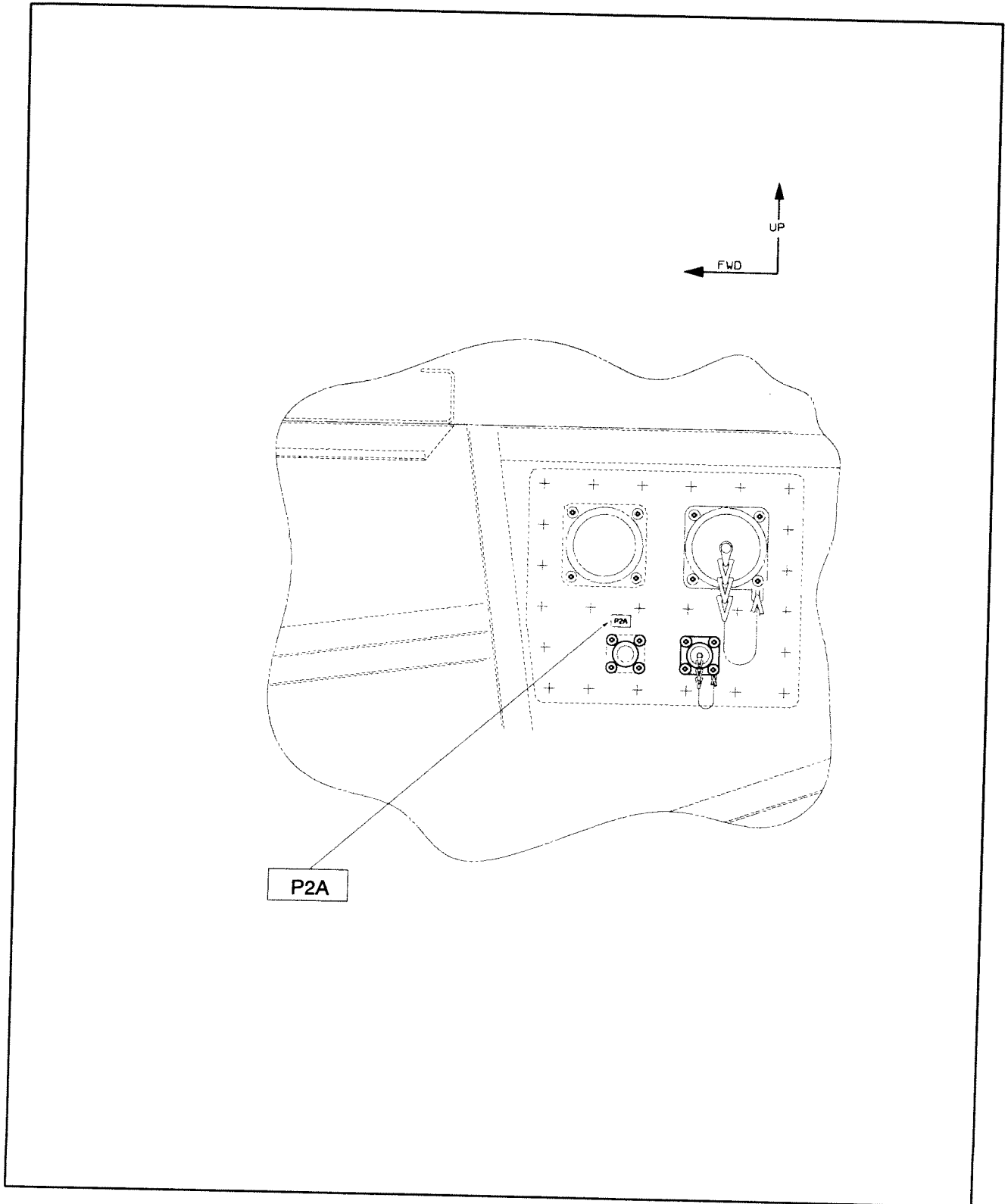
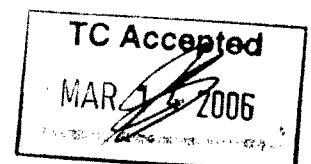

Figure 17 View showing label location on Fuselage LHS for installation with SLASS

Transport Canada Accepted



S P E C T R O L A B

A BOEING COMPANY

SX-16 Nightsun® Searchlight
Safety and Service Bulletin # SL 0899-01

Date: 08/25/99

WARNING: TO AVOID A POTENTIALLY DANGEROUS SITUATION WHICH COULD CAUSE PROPERTY DAMAGE, ENSURE THAT THE GIMBAL ASSEMBLY IS INSPECTED AND / OR REPLACED AS DESCRIBED IN THIS BULLETIN.

Subject: Gimbal Arm Corrosion

Affected Products:

SX-16 Nightsun® and SX-5 Starburst® Searchlight gimbal arm assemblies. The gimbal arm assembly is the portion of the searchlight system which is the (U-shaped) mechanical mount between the searchlight and aircraft mount. It provides movement of the searchlight via two motorized gearbox assemblies.

Dear Nightsun® and/or Starburst® Searchlight Product User:

Under certain environmental conditions, portions of the gimbal arm assembly may lose their protective finish and become corroded. Corroded gimbal arms may not have sufficient mechanical strength to carry the loads of your searchlight.

Weakened gimbal assemblies may eventually fracture or break, causing a separation between the gimbal arm and the doubler plate. This situation would leave the searchlight and/or gimbal assembly suspended by the safety cables.

SPECTROLAB

A BOEING COMPANY

Spectrolab, Inc. Safety and Service Bulletin # SL 0899-01 dated 08/25/99 (continued)

What you should do:

Perform the service procedure described within 50 flight hours or 30 days from receipt of this notification. Document # SL 0899-01A which follows, will guide you through the inspection and rework process.

What is included with this bulletin:

1. Document #SL 0899-01 – (This letter)
2. Document # SL 0899-01A – *SX-16 and SX-5 GIMBAL INSPECTION, FINISH TOUCH-UP INSTRUCTIONS and LIFE LIMITS*

If you want Spectrolab to perform this service for you, please call our Customer Service Department at 1-800-936-4888 for instructions and a return authorization number.

If you have any questions or comments, please contact us at any of the numbers below.

Sincerely,

Edward W. Ringo
Customer Service Manager
Spectrolab, Inc.

E-mail: eringo@spectrolab.com
Phone: (818) 898-2881
Fax : (818) 365-7680

S P E C T R O L A B

A BOEING COMPANY

**Bulletin # SL0899-01A
SX-16 and SX-5 GIMBAL INSPECTION, FINISH TOUCH-UP INSTRUCTIONS
and LIFE LIMITS**

Date: 08/25/99

APPLICABILITY:

SX-16 aluminum Gimbals - P/N 019059 and P/N 021716, all dash numbers and all serial numbers

SX-16 IFCO and SX-16P steel Gimbals P/N 022955, all dash- and serial numbers.

SX-5 Gimbals - P/N 030040, all dash numbers and all serial numbers

SUMMARY:

All SX-16 and SX-5 gimbals must be inspected within 50 flight hours or 30 days from receipt of this notification. This procedure will help you determine if there is evidence of corrosion or cracks in the area of the doubler rivets on your gimbal arm assembly. Subsequent inspections must take place every 6 months or 300 flight hours, whichever is less.

Corrosion of the gimbal arm in the area of the rivets can lead to weakening, cracks, and ultimately failure. Weakened gimbal assemblies may eventually fracture or break. This situation would leave the searchlight and/or gimbal assembly suspended by the safety cables.

The gimbal's paint or powder coat finish must also be inspected for evidence of peeling, chips, or nicks which can expose the surface or interior sections to corrosive salt spray or other atmospheric corrosives. Of particular concern is the finish in the area of the rivets. Here, the finish prevents corrosives from seeping in around the rivets.

Regardless of the environmental conditions, the maximum service life of aluminum gimbal arms is seven (7) years. The maximum service life of a steel gimbal arm is ten (10) years.

SPECTROLAB

A BOEING COMPANY

**Bulletin # SL0899-01A
SX-16 and SX-5 GIMBAL INSPECTION , FINISH TOUCH-UP INSTRUCTIONS
and LIFE LIMITS**

Date: 08/25/99

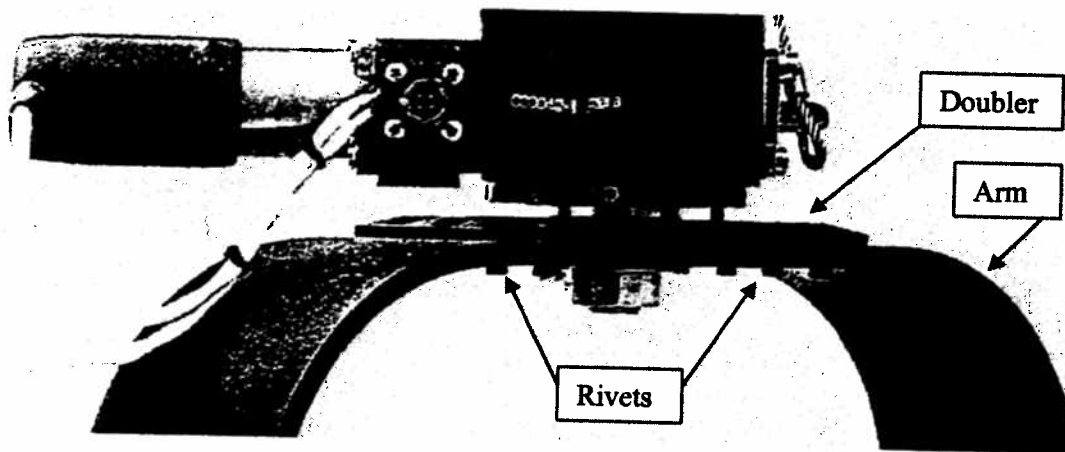

Figure 1. Upper portion of gimbal arm with doubler and rivets identified. See text for inspection procedure and criteria.

1. INSPECTION INTERVAL, PROCEDURE AND CRITERIA:

1.1. INSPECTION INTERVAL:

1.1.1. Initial inspection: All gimbals which have been in service for 2 years or more must be inspected within 50 flight hours or 30 days of receipt of these instructions.

1.1.2. Subsequent ongoing inspections: All gimbals must be inspected every 6 months or 300 flight hours, whichever is less.

SPECTROLAB

A BOEING COMPANY

Bulletin # SL0899-01A
SX-16 and SX-5 GIMBAL INSPECTION , FINISH TOUCH-UP INSTRUCTIONS
and LIFE LIMITS

Date: 08/25/99

1.2. INSPECTION PROCEDURE AND CRITERIA:

- 1.2.1** Remove the searchlight from the gimbal and remove the gimbal from the aircraft.
- 1.2.2.** To clean the gimbal, use a general purpose aircraft cleaner, a mild solvent such as isopropyl alcohol, or a soapy water solution. Remove all traces of dirt, grease, debris or salt buildup from the gimbal arm. Let dry thoroughly.
- 1.2.3.** In a well lighted area, examine the entire gimbal arm for signs of cracks, corrosion and chipped or peeling paint. Pay particular attention to the area of the doubler and the rivets, indicated in *Figure 1*. This inspection must be carried out by a qualified airframe mechanic trained in the visual inspection of rivets and mechanical structures. If any cracks or loose or broken rivets are found, the arm must be replaced.
- If evidence of corrosion, peeling, or chipped paint is found, identify the area(s) for further inspection under magnification. There may also be isolated areas of corrosion under the powder coating which may have initiated at the site of a pinhole in the coating. This type of corrosion may manifest itself as a lump in the paint or powder coat. If a lump in the coating is found, it should be removed locally with a sharp blade to determine if there is corrosion underneath.
- 1.2.4.** Continue the inspection using a hand held 5x to 10x magnifier. If any corrosion spots were identified with the unaided eye, examine them under magnification to determine their extent. If they are surface level only, they may be cleaned off and painted per **Section 2 - TOUCH-UP PROCEDURE (below)**. Inspect for evidence of separation or peeling of the aluminum. Corrosion and/or pitting which is more than .010" (0.25 mm) deep or over 0.125" (3.2 mm) in diameter should not be repaired. In this instance, the gimbal arm must be replaced.
- 1.2.5.** Take a 0.005" x 1/2" wide (0.125 mm x 10 mm wide) feeler gauge and try to insert it between each of the ends of the doubler and the gimbal arm. If it can be inserted over 0.25" (6 mm), this indicates there is separation between the gimbal arm and the doubler, and the arm assembly must be replaced.
- 1.2.6. Return to service:** If the inspection does not reveal any corrosion, cracks, loose rivets, or peeling or chipped paint, the gimbal arm may be returned to service if it is not over 7 or 10 years old, as described in *Section 3, LIFE LIMITS (below)*. Ensure that all safety cables are reattached when the gimbal is installed on the aircraft.

SPECTROLAB

A BOEING COMPANY

Bulletin # SL0899-01A
SX-16 and SX-5 GIMBAL INSPECTION, FINISH TOUCH-UP INSTRUCTIONS
and LIFE LIMITS

Date: 08/25/99

2. TOUCH-UP PROCEDURE:

2.1. Repairing paint chips: If the inspection shows only a few spots of chipped or peeling paint or powder coat, the finish may be touched up with an **aircraft exterior rated flat black or semi-gloss black paint**. Light sanding around the chips or peeling areas may be required for blending and good adhesion of the new finish. Follow the paint manufacturer's instructions.

2.2. Removing corrosion and repainting

2.2.1. Removing Corrosion: If the inspection revealed only a few spots of superficial corrosion, and it is not in the area of the doubler rivets, it may be removed locally either by sandpaper or other mechanical abrasion, airbrush-sandblasting or aircraft approved chemical corrosion removers.

For gimbal P/N 019059 and P/N 030040, use an aircraft rated aluminum corrosion remover appropriate for use on 7075 aluminum alloy. Follow the manufacturer's instructions. Be sure to remove all residue before painting.

For gimbal P/N 022955, use an aircraft rated steel corrosion / rust remover appropriate for use on 4130 alloy steel. Follow the manufacturer's instructions. Be sure to remove all residue before painting.

2.2.2. Preparing for painting: After removal of the surface trace corrosion, those areas (or the whole arm) may be sanded lightly with medium 120 or 220 grit sandpaper, then wiped clean of sanding residue. If the primer and/or paint which is going to be used requires any further surface preparation before application, follow the manufacturer's instructions. If the entire arm is going to be repainted, it is recommended the gearboxes and other attaching hardware, wiring, etc., be removed from the arm.

2.2.3. Touch-up Painting: The arm should be primed as required and touched up with aircraft exterior rated primer and flat black or semi-gloss black paint, per the manufacturer's instructions. Use a primer rated for aluminum if your gimbal P/N is 019059, P/N 030040 or P/N 021716. Use a primer rated for steel if your gimbal P/N is 022955. If the area around the ID tag is anticipated, be sure to mask the tag to preserve its data.

2.2.4. Return to Service: Reassemble per instructions in the Service manual. **Ensure that all safety cables are reattached when the gimbal is installed on the aircraft.**

SPECTROLAB

A BOEING COMPANY

**Bulletin # SL0899-01A
SX-16 and SX-5 GIMBAL INSPECTION, FINISH TOUCH-UP INSTRUCTIONS
and LIFE LIMITS**

Date: 08/25/99

3. LIFE LIMITS and REPLACEMENT PARTS:

- 3.1. If the gimbal arm fails the inspections as described in Section 1 (corrosion, cracking, loose rivets, or separation between the arm and the doubler), the arm must be replaced.**
- 3.2. The maximum service life of an aluminum gimbal arm is seven (7) years. The maximum service life of a steel gimbal arm is ten (10) years.**
- 3.3. Removal and Replacement information - Removal and replacement of the gearboxes, mechanical attachments, wiring and electrical connector from the arm can be performed at your local maintenance facility. Instructions for this procedure are located in the Searchlight Maintenance Manual. Contact the Customer Service department for further information.**
- 3.4. ID Tag information and serial numbering. When the gimbal arm is replaced, it is important to affix a new identification tag to ensure traceability of the hardware. Have the serial number and gimbal part number ready when ordering replacement parts and ask the Customer Service representative to include the identification tag with your order.**

For additional information contact:

**Spectrolab, Inc.
Attention: Customer Service
12500 Gladstone Ave.
Sylmar, California 91342**

**Tel: (800) 936-4888
Fax: (818) 365-7680
Email: customerservice@spectrolab.com**