





AIRBUS HELICOPTERS CANADA LIMITED
SUBJECT:

 Required maintenance for Standard Interior Modification, Document Holder
 (P/Ns 350-701074, 350-702104, and 350-702124)

APPLICABILITY :

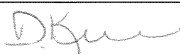
 Aircraft with the subject modification embodied in accordance with TCCA STC
 No. SH12-28 or any relevant foreign approvals.

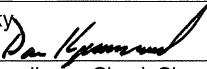
THE INFORMATION CONTAINED IN THIS DOCUMENT SHALL BE TREATED AS THE PROPERTY OF AIRBUS HELICOPTERS CANADA LIMITED (AHCA). THE RECIPIENT OF THIS DOCUMENT SHALL NOT DISCLOSE ANY INFORMATION CONTAINED HEREIN TO THIRD PARTIES WITHOUT THE WRITTEN PERMISSION OF AHCA, AND SHALL NOT USE OR REPRODUCE THIS DOCUMENT IN WHOLE OR IN PART FOR ANY PURPOSE OTHER THAN ITS ORIGINALLY INTENDED PURPOSE, OR TO EVALUATE ITS CONTENTS.

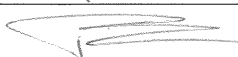
	NAME AND SIGNATURE	DATE	COMPANY DEPARTMENT
PREPARED BY:	D. Kerr 	15 Feb, 2018	AHCA ENGINEERING
PREPARED BY:			
CHECKED BY:	P. Sharpe 	15 FEB 2018	AHCA ENGINEERING
CHECKED BY:	D. Kapuscinsky 	FEB 15 2018	AHCA QUALITY ASSURANCE
REV 3 ACCEPTED BY: (Civil A/W Authority)	(As per ICA Compliance Check Sheet) 	MAR 21 2018	TCCA
REV 3 RELEASED BY:	P. Sharpe 	MAR 21 2018	AHCA ENGINEERING

RECORD OF REVISIONS

Rev.	Pages at this Revision	Description, Reason Changed Pages	Prepared (name and date)	Checked (name and date)	App'd/Acc'd (Civil A/W Authority) (name and date)	Released (name and date)
0	1 through 10 A1 B1 C1 to C3	New Issue.	D. Kerr 19 Jan., 2012	C. Timmins 19 Jan., 2012	N/A	P. Garofalo 9 March 2012
1	1 through 10 A1 B1 to B3	Part Number corrected. Addition of 150 flight hr inspection for AS 350 B2/B3. Appendix revised. (Pages 3, 4, 6, and 8)	D. Kerr 21 March 2012	C. Timmins 21 March 2012	TCCA Kam Chan 5 April 2012	R. Manson 11 April 2012
2	1 through 10 A1 B1	Addition of company logo, name change and template change. Addition of AS 355 aircraft type to document. Airworthiness limitations revised (Pages 3, 4, 6 to 8)	D. Kerr 4 Sept. 2014	C. Timmins 4 Sept. 2014	TCCA G. David 11 Nov. 2014	P. Sharpe 11 Nov. 2014
3	1 through 10 A1, B1	General rewrite adding the document holders for SICMA 159 and 198 seats. No revision bars. Appendix A deleted.	See page 1.	See page 1.	See page 1.	See page 1.

NOTE: Revisions to this document will be distributed to operators of this equipment by the STC holder.
 NOTE: Revised portions of affected pages are identified by a vertical black line in the margin adjacent to the change.
 NOTE: Minor changes are released in accordance with TCCA - ACCEPTED CAR 521.154 procedures (ref. DAPM-E-0001).

CONTENTS

SECTION	TITLE	PAGE
1	GENERAL	4
2	AIRWORTHINESS LIMITATIONS	7
3	CONTROL AND OPERATION	8
4	INSPECTION SCHEDULE AND MAINTENANCE ACTION	8
5	REPLACEMENT COMPONENTS AND REPAIR / OVERHAUL INFORMATION	8
6	TROUBLESHOOTING	8
7	SPECIAL TOOLING	8
8	REMOVAL AND REPLACEMENT	9
9	WEIGHT AND BALANCE DATA	9
10	PLACARDS AND MARKINGS	10
Appendix A	Deleted	
Appendix B	Document Holder Cleaning Information (1 page)	

FIGURES

FIGURE	TITLE	PAGE
1	Document Holder for SICMA 198 Seat	4
2	Document Holder for SICMA 159 Seat	5

TABLES

TABLE	TITLE	PAGE
1	Inspection Schedule and Maintenance Action Every 150 FH or 12 M (Margins: 15 FH or 36 D)	8

AIRBUS HELICOPTERS CANADA LIMITED
1. GENERAL

A. The subject Standard Interior Modification, Document Holder Installations are defined by AHCA drawing numbers:

- 350-701074 for the SICMA 159 seat, superseded by,
- 350-702104 for the SICMA 159 seat,
- 350-702124 for the SICMA 198 seat.

Document holders manufactured from leather and aluminium sheet, are secured to the back of the forward seats. The fire extinguisher can not be installed on the seat when this document holder is also installed.

It is the installer's responsibility to obtain the necessary airworthiness approval for any additional modification to the seats.

Refer to Figures 1 and 2 for Layout and Details.

B. These Instructions for Continued Airworthiness are applicable to aircraft with the subject modification embodied.

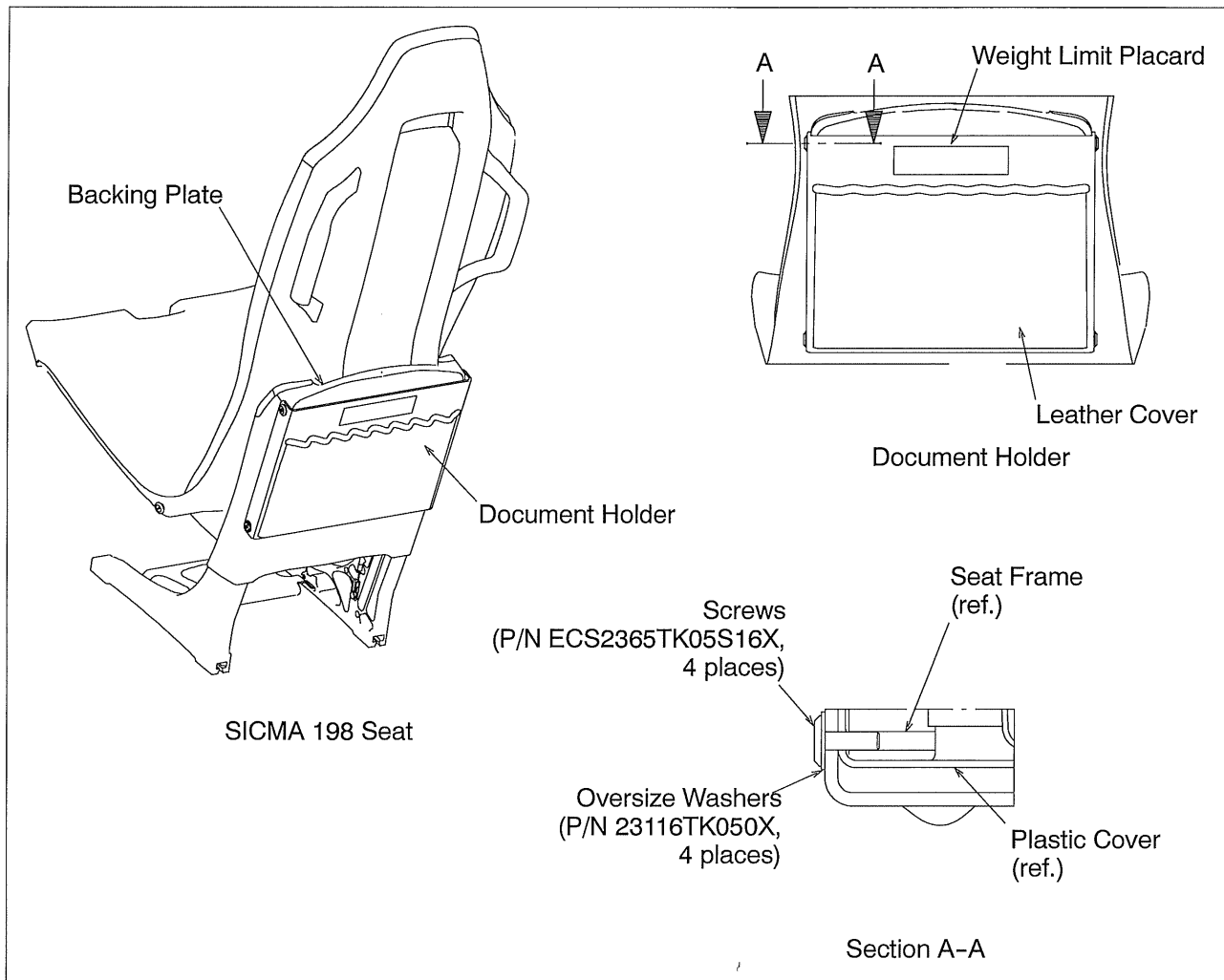

Figure 1 Document Holder for SICMA 198 Seat

Transport Canada – Accepted

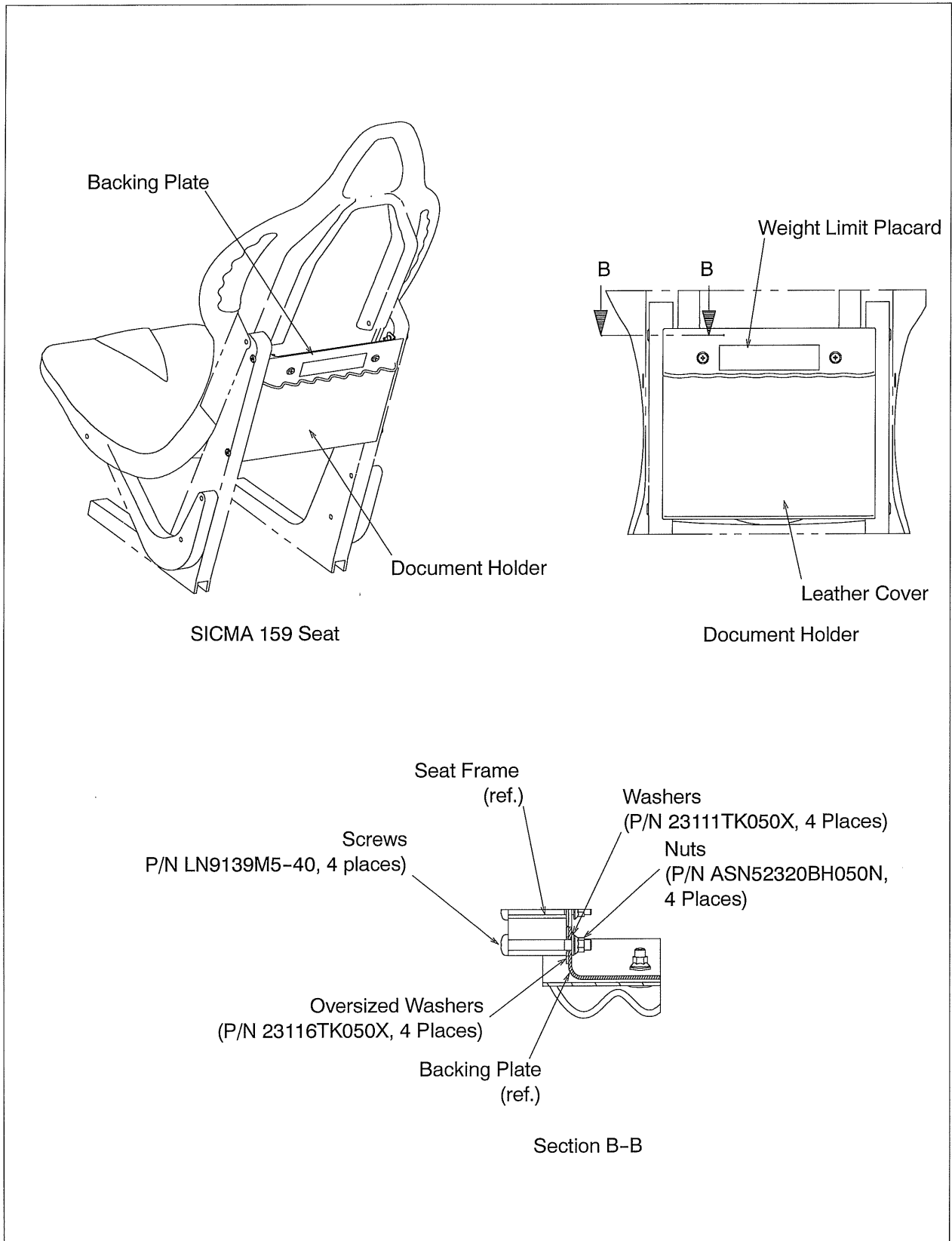

Figure 2 Document Holder for SICMA 159 Seat

Transport Canada - Accepted

AIRBUS HELICOPTERS CANADA LIMITED
C. REFERENCES

DOCUMENT	DOCUMENT TITLE
MTC (all aircraft)	Standard Practices Manual

D. ABBREVIATIONS & DEFINITIONS

ABBREVIATION	DEFINITION
Acc'd	Accepted
AHCA	Airbus Helicopters Canada Limited
AH	Airbus Helicopters
App'd	Approved
A/W	Airworthiness
CAR	Canadian Aviation Regulations
D	Days
DAPM	Design Approval Procedures Manual
FAA	Federal Aviation Administration
FH	Flight Hours
i. e.	for example
M	Months
ref.	reference
STC	Supplemental Type Certificate
TCCA	Transport Canada Civil Aviation

E. UNITS OF MEASUREMENT

ABBREVIATION / SYMBOL	UNIT OF MEASUREMENT
kg	kilogram
lb	pound
m	meter
mm	millimeters
in	inch
§§	Sections

Transport Canada – Accepted

AIRBUS HELICOPTERS CANADA LIMITED**2. AIRWORTHINESS LIMITATIONS**

The Airworthiness Limitations Section is approved by the Minister and specifies maintenance required by any applicable airworthiness or operating rule unless an alternative program has been approved by the Minister.

The Airworthiness Limitations Section is FAA approved and specifies inspections and other maintenance required under §§ 43.16 and 91.403 of the Federal Aviation Regulations unless an alternative program has been FAA approved.

The Airworthiness Limitations Section is approved and variations must be approved.

No Airworthiness Limitations associated with this installation.

AIRBUS HELICOPTERS CANADA LIMITED
3. CONTROL AND OPERATION

Control and operation of the aircraft remains unchanged.

4. INSPECTION SCHEDULE AND MAINTENANCE ACTION

NOTE: Use torque per MTC, Chapter 20-02-05-404, unless otherwise specified.

4.1. INSPECTION SCHEDULE

4.1.1. Every 150 FH or 12 M (Margins: 15 FH or 36 D) to coincide with the 150 FH or 12 M helicopter inspection, whichever occurs first:

ITEM	INSPECTION OR MAINTENANCE WORK	CORRECTIVE ACTION
A	- Check document holders, shown in Figures 1 and 2, for: a. security b. wear (visible fading, fraying, cuts etc.) c. cleanliness	a. Secure as required. b. Excessive wear is not permitted. If excessive wear is evident, contact AHCA for replacement parts. c. For cleaning instructions refer to Appendix B.
B	- Check placards and markings (refer to Section 10) for: a. legibility b. secure mounting	a. If placards have become illegible, contact AHCA for replacement parts b. Secure or reattach placards as required.

Table 1 Inspection Schedule and Maintenance Action

Every 150 FH or 12 M to coincide with the 150 FH or 12 M helicopter inspection, whichever occurs first

5. REPLACEMENT COMPONENTS AND REPAIR / OVERHAUL INFORMATION

Contact AHCA for replacement component parts. No overhaul information for this installation.

For replacement components contact:

Airbus Helicopters Canada Limited
 1100 Gilmore Road, P.O. Box 250
 Fort Erie, Ontario L2A 5M9 Canada
 Telephone:(905) 871-7772

www.airbushelicopters.ca

6. TROUBLESHOOTING

There are no unique characteristics which require troubleshooting techniques.

7. SPECIAL TOOLING

No special test equipment or tools are required. Standard tools are adequate.

AIRBUS HELICOPTERS CANADA LIMITED
8. REMOVAL AND REPLACEMENT
A. REMOVAL

- 1) DOCUMENT HOLDER for SICMA 198 SEAT (Refer to Figure 1)
 - a) Remove screws (4 places) and oversized washers (4 places) securing the document holder to seat frame. Retain hardware for reinstallation.
 - b) Remove document holder from the back of the forward seat(s) and place on workbench.
- 2) DOCUMENT HOLDER for SICMA 159 SEAT (Refer to Figure 2)
 - a) Remove screws (4 places), washers (4 places), oversized washers (4 places) and nuts (4 places) securing the document holder to seat frame. Retain hardware for reinstallation.
 - b) Remove document holder from the back of the forward seat(s) and place on workbench.

B. REPLACEMENT

NOTE: Use torque per MTC, Chapter 20-02-05-404, unless otherwise specified.

- 1) DOCUMENT HOLDERS for SICMA 198 SEAT (Refer to Figure 1)
 - a) Secure document holder to seat frame using screws (4 places) and oversized washers (4 places).
- 2) DOCUMENT HOLDERS for SICMA 159 SEAT (Refer to Figure 2)
 - a) Secure document holder to seat frame using screws (4 places), washers (4 places), oversized washers (4 places) and nuts (4 places).

9. WEIGHT AND BALANCE DATA

A. <u>Removed Items</u>						
DESCRIPTION	WEIGHT		ARM		MOMENT	
	kg	lbs	m	in	kg m	lb in
(not applicable)	0.00	0.0	0.00	0.0	0.00	0.0
Total	0.00	0.0	0.00	0.0	0.00	0.0

B. <u>Added Items (for SICMA 198 Seat)</u>						
DESCRIPTION	WEIGHT		ARM		MOMENT	
	kg	lbs	m	in	kg m	lb in
Document Holder (quantity 1)	0.40	0.9	1.62	63.8	0.65	57.4
Total	0.40	0.9	1.62	63.8	0.65	57.4

C. <u>Added Items (for SICMA 159 Seat)</u>						
DESCRIPTION	WEIGHT		ARM		MOMENT	
	kg	lbs	m	in	kg m	lb in
Document Holder (quantity 1)	1.00	2.2	1.62	63.8	1.62	140.4
Total	1.00	2.2	1.62	63.8	1.62	140.4

AIRBUS HELICOPTERS CANADA LIMITED

10. PLACARDS AND MARKINGS

- A) For Document Holder Installations, part numbers 350-702104 or 350-702124:

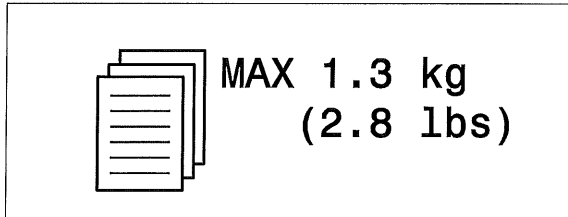

- B) For Document Holder Installations, part number 350-701074:

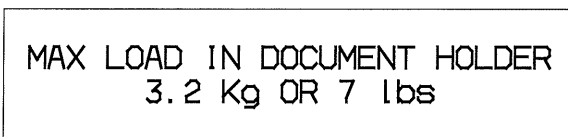

Deleted

Spinneybeck

Leather

Recommended General Maintenance

We are often asked, "Is leather practical?" The answer to this depends on your definition of practical. If we expect leather to be "plastic perfect" and never show use or develop a patina, it might not be practical. But if we understand and appreciate the changing beauty of fine, natural leather and its amazing durability, it is most practical.

Leather is resilient. It will outwear textiles many times over. Since fabrics are woven, any change in their appearance from age and use detracts from their beauty. Leather, on the other hand, adjusts to its environment. It mellows gracefully with age. Leather is expected to change; even the oils from our hands help to develop the patina.

Full grain leather is not demanding and requires very little care. It should not be abused by harsh cleaners or substances such as wax or mink oils, saddle soap or other leather polishes. These become surface sealants which keep premium full grain leathers from breathing (hence they will eventually dry out and crack). A periodic wipe with a cool damp cloth is sufficient means of cleaning under normal conditions.

The following guidelines will help you to maintain the beauty of Spinneybeck leather without destroying any of the natural characteristics:

Finished Leather: Acqua, Alaska, Amazon, Andes, Antique, Derby, Ducale, España, Forte, Hand Tipped, Leather Tiles, Lucente, Portofino, Sabrina, Salon, Velluto Pelle, Volo

Finished leather, the most popular, is smooth and has a satiny finish. Its breathable protective finish makes it most suitable for high traffic areas or contract use. It is maintained by wiping with a cool, damp cloth. For tougher soiling, use a pH balanced soap on a cloth and rinse. Remember to always use cool water. Repeat if needed.

Naked Leather: Arizona,* Belting Leather,* Capri,* Copenhagen,* Cordovan,* Distressed,* Prima, Riva, Saddle

Naked leathers have no surface or impregnated finish, other than dye matter, which may mask or alter the natural state of the leather. There is no barrier against spillage or staining, therefore, naked leather should be selected with this in mind.

The only recommended cleaning method for a naked leather is to wipe the entire surface with a soft cloth and cool water. Do not spot rub, for it will darken only that area. The idea is to even out any abrasions or stains.

** Leathers noted should be cleaned as a naked leather due to their very light application of finish.*

Grain Sueded Leather: Ducale Velour, Marissa

Full grain leathers that have been lightly buffed to raise the nap of the surface are referred to as "grain sueded" leathers. This produces the softest hand of any suede leathers. For maximum soil resistance and durability these leathers have received an impregnated soil resistant treatment.

Grain sueded leather can be maintained with reasonable care as spillage will bead up and roll off. However, it should not be allowed to puddle, but be blotted up immediately. For normal care, grain sueded leather should be dry brushed occasionally. Remove general soilage with a suede cleaning block.

Textured Sueded Leather: Maremma

Textured Sueded Leather is an aniline dyed leather with a dense sueded surface. The textured surface is protected by an impregnated, soil resistant treatment which shields the surface without disturbing the suppleness and rich coloration.

Textured sueded leather can be maintained with reasonable care as liquids will bead allowing spillage to be blotted up immediately. For normal care, the surface of textured suedes should be brushed occasionally with a scotch brite pad followed by vacuuming to remove dirt and loose fibers.

Note: Certain inks or stains cannot be removed from leather just as they cannot be removed from other upholstery fabrics. Use caution to avoid these accidents. Remember that our leathers are all natural "skins." Treat your leather the same way you would treat your own skin.

Please call for more information about Spinneybeck Maintenance Kits, which include our specially formulated cleaners, conditioners and ink removers.

Updated: May 2008

Spinneybeck • 425 CrossPoint Parkway • Suite 100 • Getzville, New York 14068
(800) 482-7777 / (716) 446-2380 / (716) 446-2396 Fax
Spinneybeck Ireland • Suite 2, Morrison Chambers • 32 Nassau Street • Dublin 2, Ireland
Tel. +353 1 6729192 / Fax +353 1 6336506
www.spinneybeck.com