









SUBJECT:

Required maintenance for the Airframe Fuel Filter (P/N 350-600004).

APPLICABILITY :

Aircraft with the subject modification embodied in accordance with TCCA STC No. SH94-31 or any relevant foreign approvals.

THE INFORMATION CONTAINED IN THIS DOCUMENT SHALL BE TREATED AS THE PROPERTY OF EUROCOPTER CANADA LIMITED (ECL). THE RECIPIENT OF THIS DOCUMENT SHALL NOT DISCLOSE ANY INFORMATION CONTAINED HEREIN TO THIRD PARTIES WITHOUT THE WRITTEN PERMISSION OF ECL, AND SHALL NOT USE OR REPRODUCE THIS DOCUMENT IN WHOLE OR IN PART FOR ANY PURPOSE OTHER THAN ITS ORIGINALLY INTENDED PURPOSE, OR TO EVALUATE ITS CONTENTS.

	NAME AND SIGNATURE	DATE	COMPANY DEPARTMENT
PREPARED BY:	D. Kerr 	2 April, 2013	ECL ENGINEERING
PREPARED BY:			
CHECKED BY:	C. Timmins 	2 nd April 2013	ECL ENGINEERING
CHECKED BY:	M. Merritt 	2013-04-02	ECL QUALITY ASSURANCE
 ACCEPTED (Civil A/W Authority)	(As per ICA Compliance Check Sheet) G. David 	2013.04.03	TCCA
RELEASED BY:	P. Sharpe 	09 Apr. 1 2013.	ECL ENGINEERING



RECORD OF REVISIONS

Rev.	Pages at this Revision	Description, Reason Changed Pages	Prepared (name and date)	Checked (name and date)	App'd/Acc'd (Civil A/W Authority) (name and date)	Released (name and date)
0	1 through 11	Original Issue (Replaces MMS)	D. Kerr 29 July, 2004	C. Timmins 30 July, 2004	N/A	R. Manson 4 August, 2004
1	1 through 13	Changes to pages 1 to 13. General, Troubleshooting, and placard locations revised as per TCCA request.	D. Kerr 8 September, 2004	C. Timmins 8 September, 2004	TCCA E. Cheung 8 September, 2004	R. Manson 8 September, 2004
2	1 through 20	Template revised. More detail added to Section 4, Inspection Schedule and Section 8, Removal and Replacement. revision to basic aircraft wiring diagram. Addition of new wiring diagram for aircraft with VEMD. Instrument panel layout with VEMD added. (Pages 3 to 20)	D. Kerr 8 May, 2007	C. Timmins 8 May, 2007	TCCA F. Eaves 8 May, 2007	R. Manson 9 May, 2007
3	1 through 20, A1 to A4	Template revised. Wiring diagram revised for a/c with VEMD. Section 4, Inspection Schedule and Maintenance Action revised, 500 flight hours to 600 flight hours. Weight and Balance chart revised. (Pages 3 to 5, 8 to 11, 13, 15 to 20)	D. Kerr 3 December, 2009	C. Timmins 3 December, 2009	TCCA F. Eaves 11 December, 2009	R. Manson 15 December, 2009

NOTE: Revisions to this document will be distributed to operators of this equipment by the STC holder.

NOTE: Revised portions of affected pages are identified by a vertical black line in the margin adjacent to the change.

Transport Canada - Accepted



RECORD OF REVISIONS

Rev.	Pages at this Revision	Description, Reason Changed Pages	Prepared (name and date)	Checked (name and date)	App'd/Acc'd (Civil A/W Authority) (name and date)	Released (name and date)
4	1 through 33 A1 to A4	Revised format. Revised the Airworthiness Limitations statement in Section 2. Addition of 150 flight hour Press to Test. Increased 100 flight hrs to 150 and 1000 flight hours to 1200 flight hours. Margins also added to Section 4. Additional information added to Section 8. Wiring diagram revised to incorporate wire changeover to laser printed. Addition of original B3 models to document. (Pages 4 to 33)	See page 1.	See page 1.	See page 1.	See page 1.

NOTE: Revisions to this document will be distributed to operators of this equipment by the STC holder.

NOTE: Revised portions of affected pages are identified by a vertical black line in the margin adjacent to the change.

Transport Canada - Accepted



CONTENTS

CHAPTER	TITLE	PAGE
1	GENERAL	6
2	AIRWORTHINESS LIMITATIONS	13
3	CONTROL AND OPERATION	14
4	INSPECTION SCHEDULE AND MAINTENANCE ACTION	14
5	REPLACEMENT COMPONENTS AND REPAIR / OVERHAUL INFORMATION	19
6	TROUBLESHOOTING	19
7	SPECIAL TOOLING	22
8	REMOVAL AND REPLACEMENT	22
9	WEIGHT AND BALANCE	27
10	PLACARDS AND MARKINGS	28
Appendix A	PUROLATOR PRODUCTS COMPANY - Operating & Design Specifications (4 pages)	

FIGURES

FIGURE	TITLE	PAGE
1	General Layout	6
2	AS 350 B, BA, B1, B2 Airframe Fuel Filter (PRE SB-ECL-109)	7
3	AS 350 B, BA, B1, B2 Airframe Fuel Filter (PRE SB-ECL-109) (continued)	8
4	AS 350 B3 Airframe Fuel Filter (POST SB-ECL-109)	9
5	AS 350 B3 Airframe Fuel Filter Installation (POST SB-ECL-109) (continued) ..	10
6	Floor Doubler and Base Installation Details	11
7	Airframe Fuel Filter, Wiring Diagram (aircraft without VEMD)	20
8	Airframe Fuel Filter, Wiring Diagram (aircraft with VEMD)	21
9	Identification labels on Instrument Panels (excluding AS 350 B3)	28
10	Identification labels on AS 350 B2 Instrument Panels	29
11	Identification labels on AS 350 B3 Instrument Panels	30
12	Placard in AS 350 B3 LH Cargo Compartment	31
13	Typical label location for the Fuel Filter Support Assembly	32
14	Identification Tags on hoses	33

Transport Canada - Accepted



TABLES

TABLE	TITLE	PAGE
1	Inspection Schedule and Maintenance Action Before the first flight of each day	14
2	Inspection Schedule and Maintenance Action Pre-Flight Check	14
3	Inspection Schedule and Maintenance Action Every 150 FH or 12 M (Margin 15 FH or 36 D)	15
4	Inspection Schedule and Maintenance Action Every 600 FH or 24 M (Margin 60 FH or 73 D)	16
5	Inspection Schedule and Maintenance Action Every 1200 FH or 48 M (Margin 120 FH or 145 D)	16
6	Troubleshooting Guide	19

Transport Canada - Accepted

1. GENERAL

- A. The Airframe Fuel Filter is installed in the fuel line between the fuel tank and the engine and provides extra protection against fuel contaminants. The filter contains a bypass valve and a bypass delta pressure switch. An annunciator light in the cockpit is provided to warn the pilot that the filter is becoming blocked. Refer to Figure 1 for General Layout.

This update incorporates the required changes defined in SB-ECL-109 for the AS 350 B3. Originally, the Airframe Fuel Filter (P/N 350-600004) for the AS 350 B3 was under TCCA STC Number SH94-31 issues 5 through 7.

NOTE: Applicable to PRE MOD 3369 and 4305 only.

MOD 3369, introduces a maximum weight increase for aircraft equipped with Arriel 2B1 engines and dual hydraulic system only.

MOD 4305, incorporates the installation of the Arriel 2D engine.

The Airframe Fuel Filter consists of the following main components:

Fixed Provisions (AS 350 B, BA, B1, B2)

- Fuel Filter Support Assembly
- Doubler

Fixed Provisions (AS 350 B3 only)

- Drain Sump Assembly
- Base
- Drain Bracket

Detachable Provisions (AS 350 B, BA, B1, B2, B3)

- Fuel Filter
- Hoses

For instructions for initial installation, see IP-ECL-12.

- B. These Instructions for Continued Airworthiness are applicable to aircraft with the subject modification embodied.

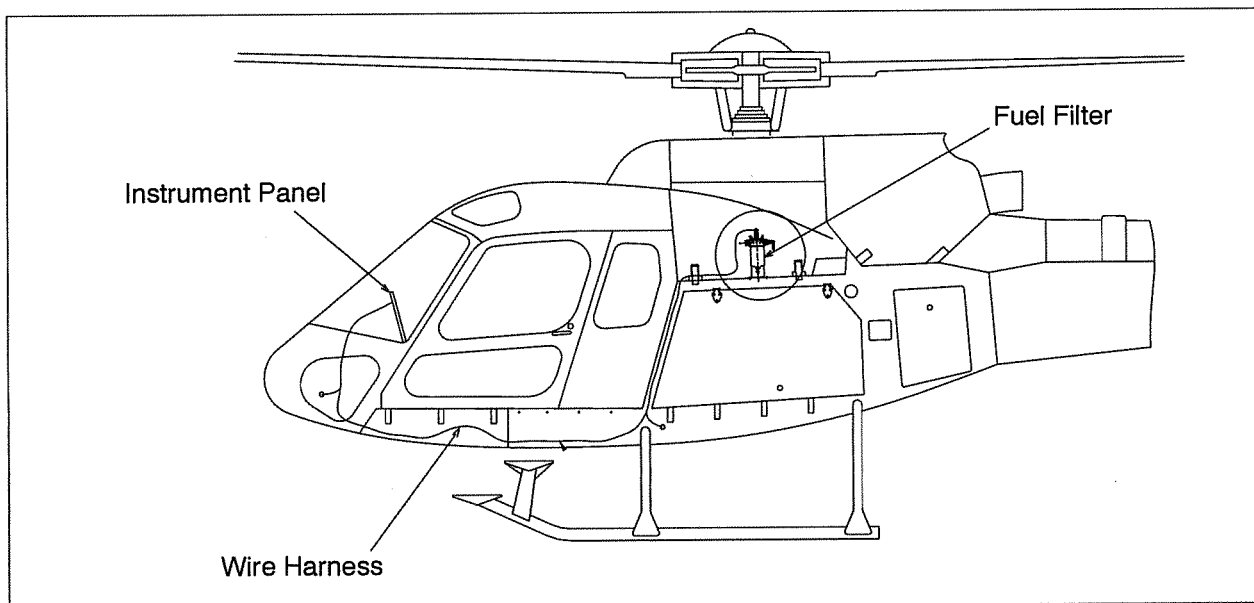

Figure 1 General Layout

Transport Canada - Accepted



Legend (for Figure 2)

Item	Description
1.	Fuel Filter Support System
2.	Fuel Filter
3.	Lockwire
4.	Packing (P/N MS29513-012)
5.	Connector
6.	Backshell
7.	Screw
8.	Washer
9.	Clamp (MS21919WDG3)
10.	Spacer
11.	Drain Valve
12.	Nut
13.	Drain hose
14.	Hose Clamp
15.	Spiral Wrap
16.	Funnel
17.	Clamp (MS21919WDG13)

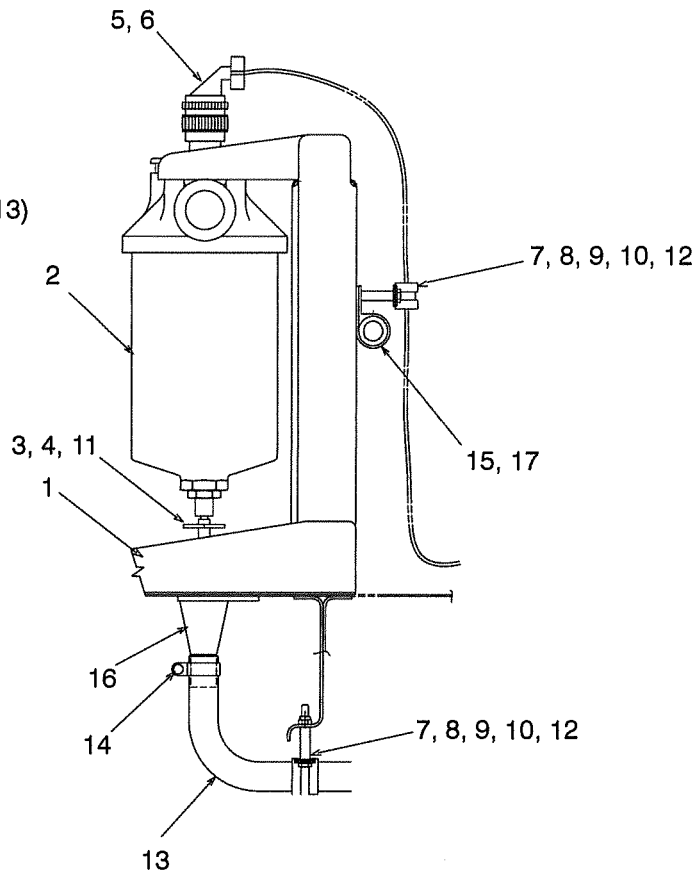
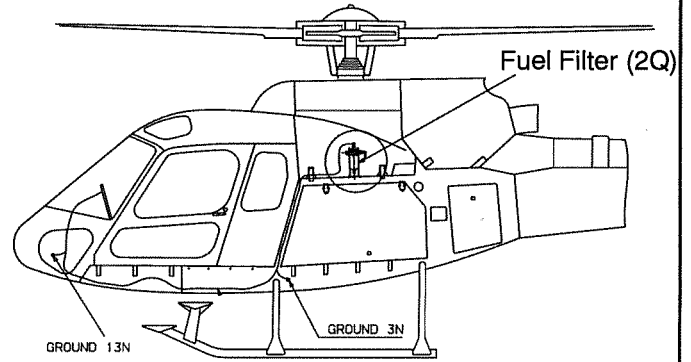

VIEW LOOKING FORWARD

Figure 2 AS 350 B, BA, B1, B2 Airframe Fuel Filter (B3 PRE SB-ECL-109)

Transport Canada - Accepted

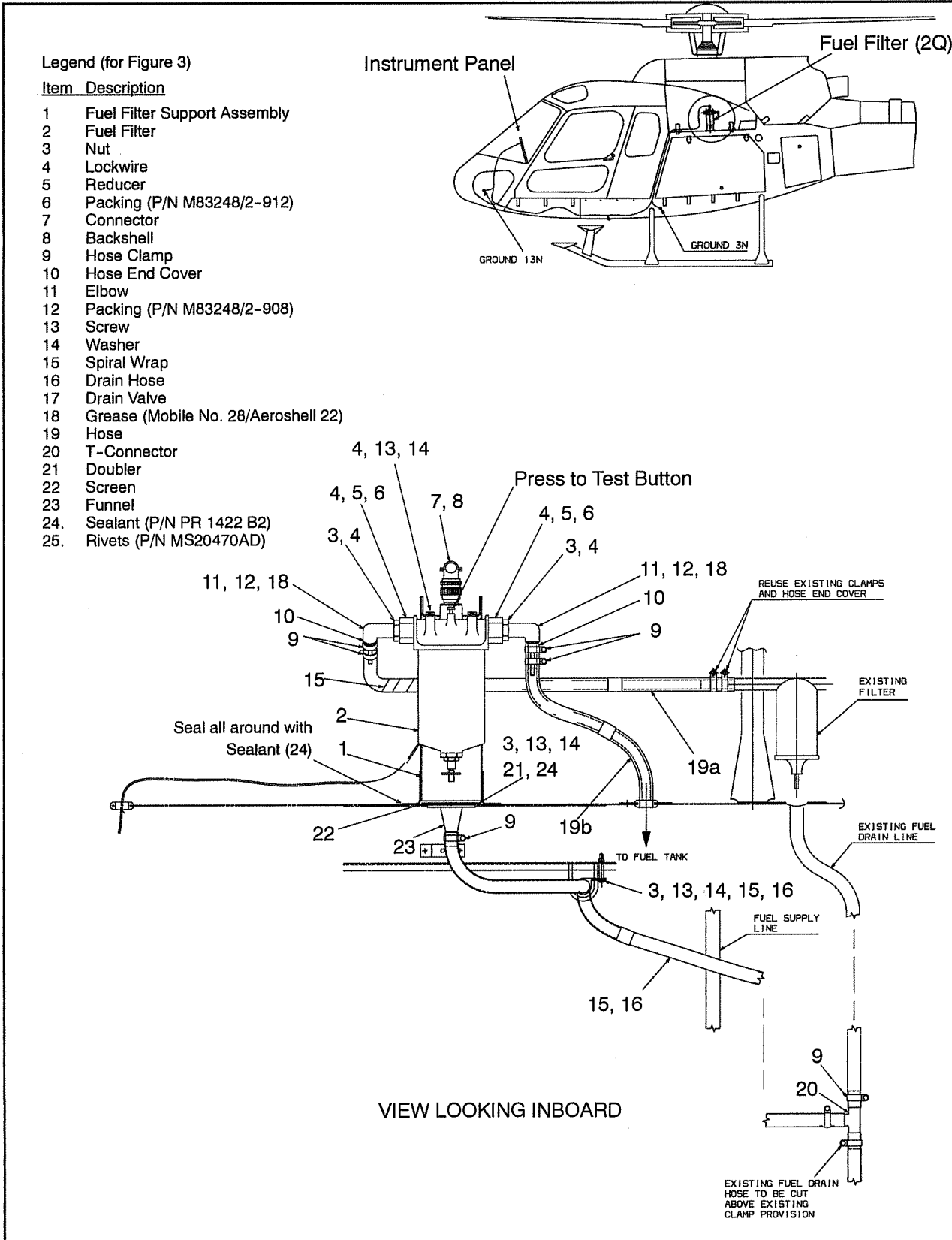

Figure 3 AS 350 B, BA, B1, B2 Airframe Fuel Filter (B3 PRE SB-ECL-109) (continued)

Transport Canada - Accepted



Legend (for Figure 4)

Item Description

1. Fuel Filter Support Assembly
2. Fuel Filter
3. Lockwire
4. Packing (P/N MS29513-012)
5. Connector
6. Backshell
7. Screw
8. Washer
9. Clamp (MS21919WDG3)
10. Nut
11. Drain Valve
12. Ty-rap
13. Drain Bracket
14. Grommet
15. Drain Sump Assembly
16. Hose Clamp
17. Drain Hose
18. Spiral Wrap
19. Base
20. Nut
21. Clamp (MS21919WDG13)

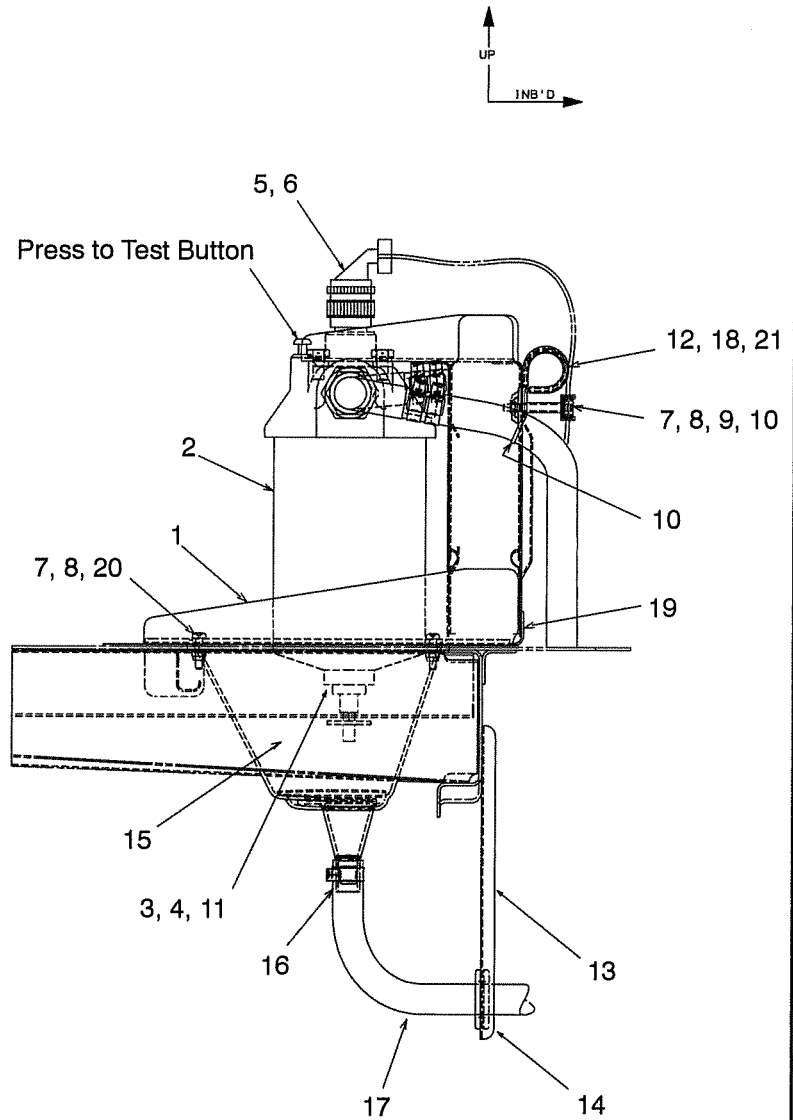

VIEW LOOKING FORWARD

Figure 4 AS 350 B3 Airframe Fuel Filter (POST SB-ECL-109)

Transport Canada - Accepted



Legend (for Figure 5)

Item Description

- 1 Fuel Filter Support Assembly
- 2 Fuel Filter
- 3 Nut
- 4 Lockwire
- 5 Reducer
- 6 Packing (P/N M83248/2-912)
- 7 Connector
- 8 Backshell
- 9 Hose Clamp
- 10 Hose End Cover
- 11 Elbow
- 12 Packing (P/N M83248/2-908)
- 13 Screw
- 14 Washer
- 15 Tyrap
- 16 Spacer
- 17 Drain Valve
- 18 Funnel
- 19 Hose (a and b)
- 20 Drain Hose
- 21 Floor Doubler
- 22 Screen
- 23 Grease (Mobile No. 28 / Aeroshell 22)
- 24 Drain Sump Assembly
- 25 Sealant (P/N PR 1422 B2)
- 26 Plate

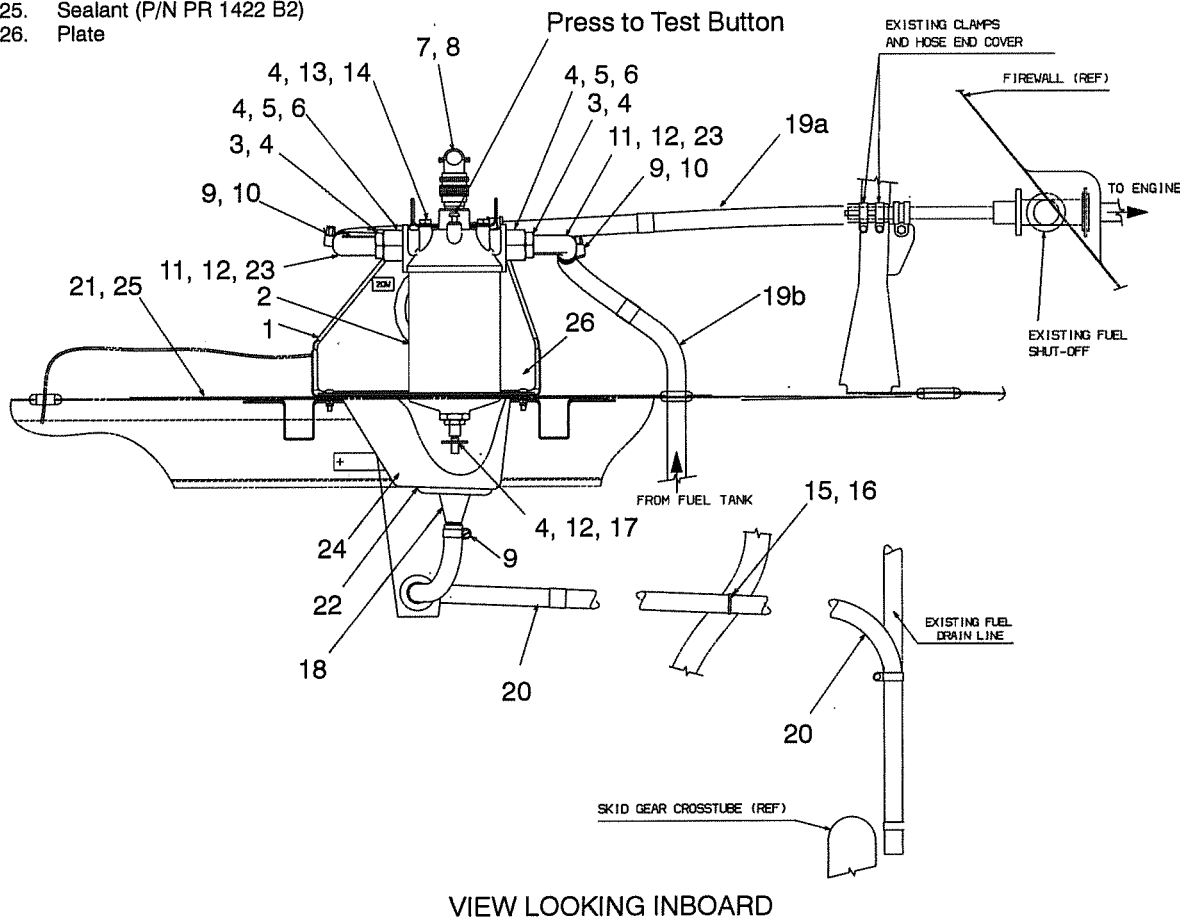

Figure 5 AS 350 B3 Airframe Fuel Filter Installation (POST SB-ECL-109) (continued)

Transport Canada - Accepted



Legend (for Figure 6)

Item	Description
1.	Floor Doubler
2.	Base
3.	Sealing Compound (PR 1422 B2)
4.	Rivets (P/N MS20470AD 4-5)
5.	Rivets (P/N MS20470AD 4-6)
6.	Rivets (P/N MS20470AD 4-7)
7.	Rivets (P/N MS20426AD 4-6)
8.	Rivets (P/N MS20426AD 4-7)
9.	Rivets (P/N MS20426AD 4-8)
10.	Rivets (P/N NAS9301B-4-02 or CR3213-4-02)
11.	Rivets (P/N NAS9301B-4-03 or CR3213-4-03)
12.	Rivets (P/N NAS9302B-4-02 or CR3212-4-02)
13.	Rivets (P/N NAS9307M-4-03 or CR3523-4-03)
14.	Rivets (P/N NAS9307M-4-05 or CR3523-4-05)

Through deck doubler (1)
and airframe only)

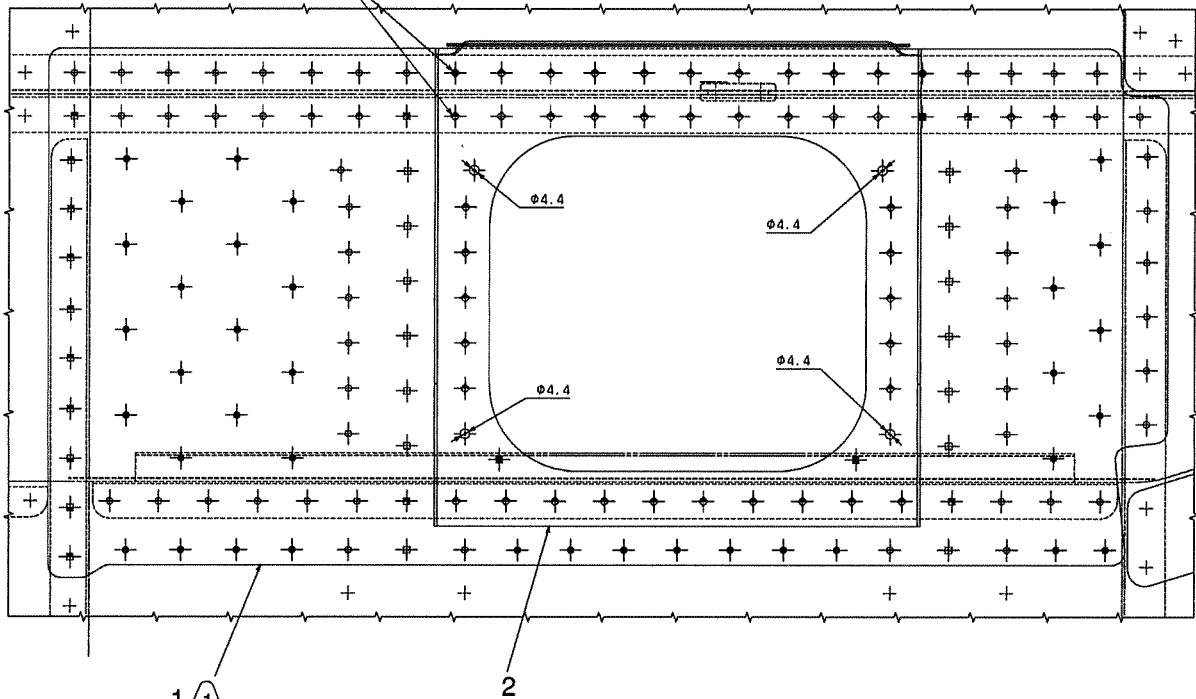

View looking down on Transmission Deck
Drain Sump Assembly and Fuel Filter not shown

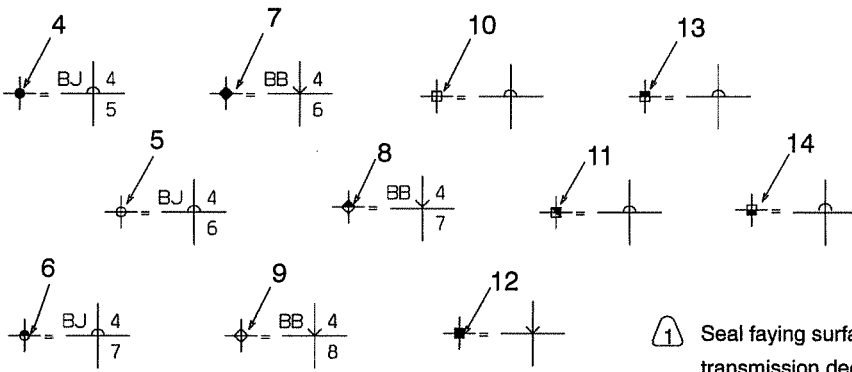

Rivets for this view shown above

① Seal faying surface and fillet seal edge of doubler (1) to transmission deck using sealant (3).

NOTES:

Figure 6 Floor Doubler and Base Installation Details

Transport Canada - Accepted

C. REFERENCES

DOCUMENT	DOCUMENT TITLE
AC-43.13 - 1B	Advisory Circular, Acceptable Methods, Techniques and Practices - Aircraft Inspection and Repair
AMM	Aircraft Maintenance Manual
MET	Maintenance Manual
MTC	Standard Practices Manual
IP-ECL-12	Installation Procedure, Airframe Fuel Filter
Manual Number 1743640-01	"Operating & Design Specifications", Fuel Filter Assembly, Purolator Products Company

D. ABBREVIATIONS & DEFINITIONS

ABBREVIATION	DESCRIPTION
A/F	Airframe
D	Days
EC	Eurocopter (France)
ECL	Eurocopter Canada Limited
D.BAT	Direct Battery
EC	Eurocopter (France)
ECL	Eurocopter Canada Limited
EPU	External Power Unit
EXT PWR BAT	External Power Battery
FH	Flight Hours
M	Months
P/N	Part Number
VEMD	Vehicle and Engine Multifunction Display

E. UNITS OF MEASUREMENT

ABBREVIATION / SYMBOL	UNIT OF MEASUREMENT
F	Fahrenheit
GPM	Gallons per Minute
in	inch
kg	kilogram
lb	pound
PSI	Pounds per Square Inch
PSID	Pounds per Square Inch Differential
®	Registered Trademark
°	degree
±	Plus or minus

Transport Canada Accepted



2. AIRWORTHINESS LIMITATIONS

The Airworthiness Limitations section is approved by the Minister and specifies maintenance required by any applicable airworthiness or operating rule unless an alternative program has been approved by the Minister. Variations must also be approved.

The Airworthiness Limitations section is FAA approved and specifies inspections and other maintenance required under Sections 43.16 and 91.403 of the Federal Aviation Regulations unless an alternative program has been FAA approved.

No airworthiness limitations associated with this installation.

Transport Canada - Approved

3. CONTROL AND OPERATION

Control and operation of the aircraft remains unchanged.

4. INSPECTION SCHEDULE AND MAINTENANCE ACTION

For additional information on operating and maintenance, refer to the "Purolator" Operating and Design Specifications, Fuel Filter Assembly Part No.: 1743640-01 manual, located in Appendix A.

NOTE: Use torque per EC, MTC, Volume 2, Chapter 20.02.05.404, unless otherwise specified.

4.1. INSPECTION SCHEDULE

4.1.1. Before the first flight of each day:

ITEM	INSPECTION OR MAINTENANCE WORK	CORRECTIVE ACTION
A	<ul style="list-style-type: none"> - Check Airframe Fuel Filter for: <ul style="list-style-type: none"> a. water in fuel b. air in fuel line c. leaks in the fuel filter and the drain valve 	<ul style="list-style-type: none"> a. Open drain valve, purge any water from the system. b. Hold drain valve open until all air is purged.. c. No leaks with fuel pump on. Check valve seating, replace packing, item 6, in Figure 2 as necessary (P/N MS29513-012)
B	<ul style="list-style-type: none"> - Turn off fuel pump and check Airframe Fuel Filter for: <ul style="list-style-type: none"> a. debris in fuel drain, below the filter and/or on the transmission deck b. secure mounting and connection of filter and hoses c. condition of electrical connector and harness 	<ul style="list-style-type: none"> a. Remove and clean as necessary. b. Secure as required. c. If cracks, fraying or burns are found, contact ECL for replacement parts.

Table 1 Inspection Schedule and Maintenance Action
Before the first flight of each day

4.1.2. Pre-Flight Check:

ITEM	INSPECTION OR MAINTENANCE WORK	CORRECTIVE ACTION
A	<ul style="list-style-type: none"> - Push A/F FUEL FILTER by-pass "Press to Test" caution light: <ul style="list-style-type: none"> a. apply power to 4 Alpha Warning Panel (Master/Battery switch to ON) and push Press to Test A/F FUEL FILTER annunciator - lamp must illuminate. 	<ul style="list-style-type: none"> a. If lamp fails to illuminate, refer to Chapter 6, Troubleshooting, item 1, in this document

Table 2 Inspection Schedule and Maintenance Action
Pre-Flight Check

Transport Canada - Accepted

4. **INSPECTION SCHEDULE AND MAINTENANCE ACTION** (continued)

4.1.3. Every 150 FH or 12 M (Margins: 15 FH or 36 D), to coincide with the 150 FH or 12 M helicopter inspection, whichever occurs first:

ITEM	INSPECTION OR MAINTENANCE WORK	CORRECTIVE ACTION
A	<p>Push the Press to Test Button on the Fuel Filter shown in Figures 3 and 5:</p> <p>a. Push the Press to Test Button on the Fuel Filter, the A/F FUEL FILTER annunciator - lamp must illuminate.</p>	<p>a. If lamp fails to illuminate, refer to Chapter 6, Troubleshooting, item 2, in this document.</p>
B	<p>- Check fuel filter support assembly, item 1, and doubler, item 21, in Figure 3 for AS 350 B, BA, B1 and B2 and Figure 5 for the AS 350 B3 for:</p> <p>a. cracks or corrosion</p>	<p>a. No cracks or corrosion are allowed. If cracks or deformation are found, contact ECL for replacement parts.</p>
C	<p>- Check drain hose, item 16, in Figure 3 and item 20, in Figure 5 for:</p> <p>a. leaks</p> <p>b. cracking</p>	<p>a. If leaks are found, contact ECL for replacement parts.</p> <p>b. No cracking is allowed. If cracking is found, contact ECL for replacement parts.</p>
D	<p>- Check drain sump assembly, item 24, for POST SB-ECL-109, AS 350 B3 in Figure 5 for:</p> <p>a. cracks and deformation</p>	<p>a. No cracks or deformation are allowed. If cracks or deformation are found, contact ECL for replacement parts.</p>
E	<p>- Check base, item 19, and drain bracket, item 13, for POST SB-ECL-109, AS 350 B3 shown in Figure 4 for:</p> <p>a. cracks and corrosion</p>	<p>a. No cracks or corrosion are allowed. If cracks or deformation are found, contact ECL for replacement parts.</p>

Table 3 Inspection Schedule and Maintenance Action
Every 150 FH or 12 M to , to coincide with the 150 FH or 12 M helicopter inspection, whichever occurs first
(continued on following page)

Transport Canada - Accepted



4. INSPECTION SCHEDULE AND MAINTENANCE ACTION (continued)

4.1.3. Every 150 FH or 12 M (Margins: 15 FH or 36 D), to coincide with the 150 FH or 12 M helicopter inspection, whichever occurs first:

ITEM	INSPECTION OR MAINTENANCE WORK	CORRECTIVE ACTION
F	<ul style="list-style-type: none"> - Check placards and markings in Figures 9, 10, 11, 12, 13 and 14 (Section 10) for: <ul style="list-style-type: none"> a. legibility b. secure mounting 	<ul style="list-style-type: none"> a. If placards and markings have become illegible, contact ECL for replacement parts. b. Secure, reattach placards as required.

Table 3 Inspection Schedule and Maintenance Action

Every 150 FH or 12 M to , to coincide with the 150 FH or 12 M helicopter inspection, whichever occurs first

4.1.4. Every 600 FH or 24 M (Margin: 60 FH or 73 D), to coincide with the 600 FH or 24 M helicopter inspection, whichever occurs first:

ITEM	INSPECTION OR MAINTENANCE WORK	CORRECTIVE ACTION
A	Perform Operational Test - Fuel Filter Switch and Bypass Valve	See Operational Test Instructions given in Section 4.1.6.

Table 4 Inspection Schedule and Maintenance Action

Every 600 FH or 24 M, to coincide with the 600 FH or 24 M helicopter inspection, whichever occurs first

4.1.5. Every 1200 FH or 48 M (Margin: 120 FH or 145 D) to coincide with the 1200 FH or 48 M helicopter inspection, whichever occurs first:

ITEM	INSPECTION OR MAINTENANCE WORK	CORRECTIVE ACTION
A	Replace Fuel Filter Element	See Replacement instructions given in Section 4.1.6.

Table 5 Inspection Schedule and Maintenance Action

Every 1200 FH or 48 M to coincide with the 1200 FH or 48 M helicopter inspection, whichever occurs first

Transport Canada - Accepted



NOTE: Filter Element can be replaced more frequently if operational elements dictate. ■

NOTE: Should the A/F FUEL FILTER annunciator light illuminate, the fuel filter element must be replaced.



A/F FUEL
FILTER

A partially blocked filter element will cause a differential pressure switch in the head assembly to close and the A/F FUEL FILTER annunciator to illuminate. If the filter element becomes fully blocked a differential pressure activated valve will permit fuel to bypass the filter.

Transport Canada - Accepted



4. INSPECTION SCHEDULE AND MAINTENANCE ACTION (continued)

4.1.6. Operational Test – Fuel Filter Switch and Bypass Valve

- a. If operating an AS 350 (excluding AS 350 B2/B3) – Observe FUEL SYSTEM General Instructions. Refer to AS 350 Maintenance Manual, Chapter 28-00-00.
If operating as AS 350 B2/B3 – Observe General Safety Instructions – Fuel System. Refer to AS 350 B2/B3 Aircraft Maintenance Manual, Chapter 28-00-00, 3-1.
- b. Apply power to annunciator panel. Press differential pressure switch Test Button, on the top of the fuel filter, A/F FUEL FILTER annunciator must illuminate.
- c. Replace filter element with clean dummy element.
- d. Turn on fuel boost pump and start engine.
- e. The A/F FUEL FILTER annunciator should illuminate.
- f. When test is successfully completed, shut down engine. Remove dummy element and install filter element. Follow instructions given in Chapter 4, Replacement – Fuel Filter Element.
- g. Operate fuel boost pump and open fuel filter bowl drain until all air is purged.

4.1.7. Replacement – Fuel Filter Element

- a. If operating an AS 350 (excluding AS 350 B2/B3) – Observe FUEL SYSTEM General Instructions. Refer to AS 350 Maintenance Manual, Chapter 28-00-00.
If operating as AS 350 B2/B3 – Observe General Safety Instructions – Fuel System. Refer to AS 350 B2/B3 Aircraft Maintenance Manual, Chapter 28-00-00, 3-1.
- b. Drain fuel from filter bowl into a container.
- c. Refer to Appendix “Operating Instructions” Purolator Products Company for Fuel Filter Element change.
- d. Operate fuel boost pump and open fuel filter bowl drain until all air is purged.

NOTE: The Purolator Filter Assembly (Part No. 1743640-01) Replacement Element Kit is also available, Purolator Products Company Part No. 1743645.02. This kit consists of a Seal, an O-ring and an Element Assembly.

Transport Canada – Accepted

5. REPLACEMENT COMPONENTS AND REPAIR / OVERHAUL INFORMATION

No replacement components and repair/overhaul information required for this installation.

6. TROUBLESHOOTING

There are no unique characteristics which require special troubleshooting techniques: standard techniques are adequate.

For electrical system troubleshooting, refer to Figure 7 Wiring Diagram (aircraft without VEMD) and Figure 8 Wiring Diagram (aircraft with VEMD).

No.	Trouble Symptom	Probable Cause	Corrective Action
1	A/F FUEL FILTER lamp does not illuminate during Daily Preflight Inspection	Bulb burnt out.	Replace bulb, P/N MS25237-327
2	A/F FUEL FILTER lamp does not illuminate during either the 150 flight hr check or the Operational Test (600 flight hr check)	Break or short in annunciator circuit Fuel Filter Head Assembly defective	Perform circuit continuity check and repair/replace wiring as applicable in accordance with AC43.13-1B, Chapter 11, Section1. Replace Head Assembly, refer to the Purolator Documentation.
3	A/F FUEL FILTER illuminates during operations.	Excessive contamination in fuel supply. Filter is blocked prematurely. Short in annunciator circuit.	Check quality of fuel supply. Replace filter element. Perform circuit continuity check and repair/replace wiring as applicable in accordance with AC43.13-1B, Chapter 11, Section1.

Table 6 Troubleshooting Guide

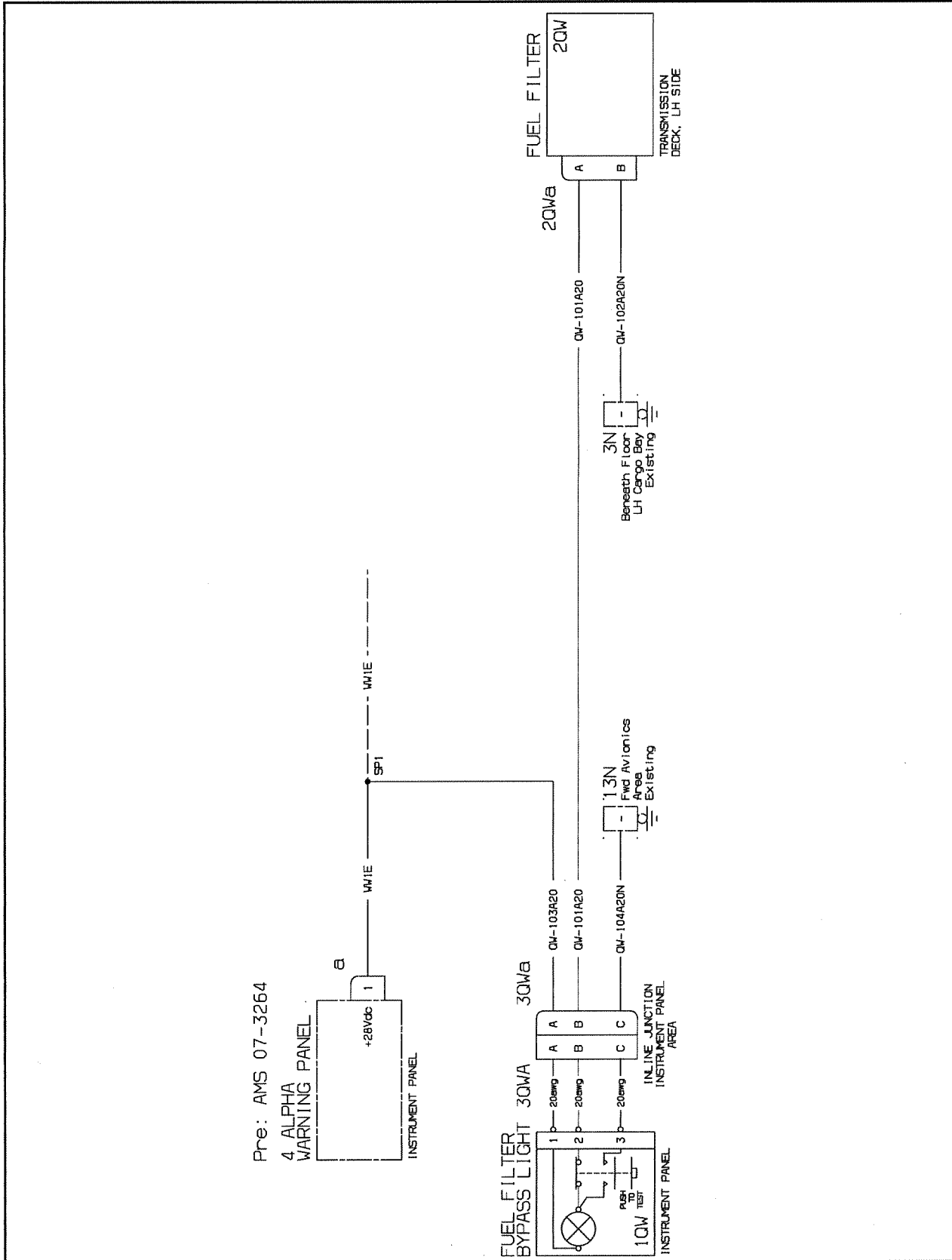

Figure 7 Airframe Fuel Filter, Wiring Diagram (aircraft without VEMD)

Transport Canada - Accepted

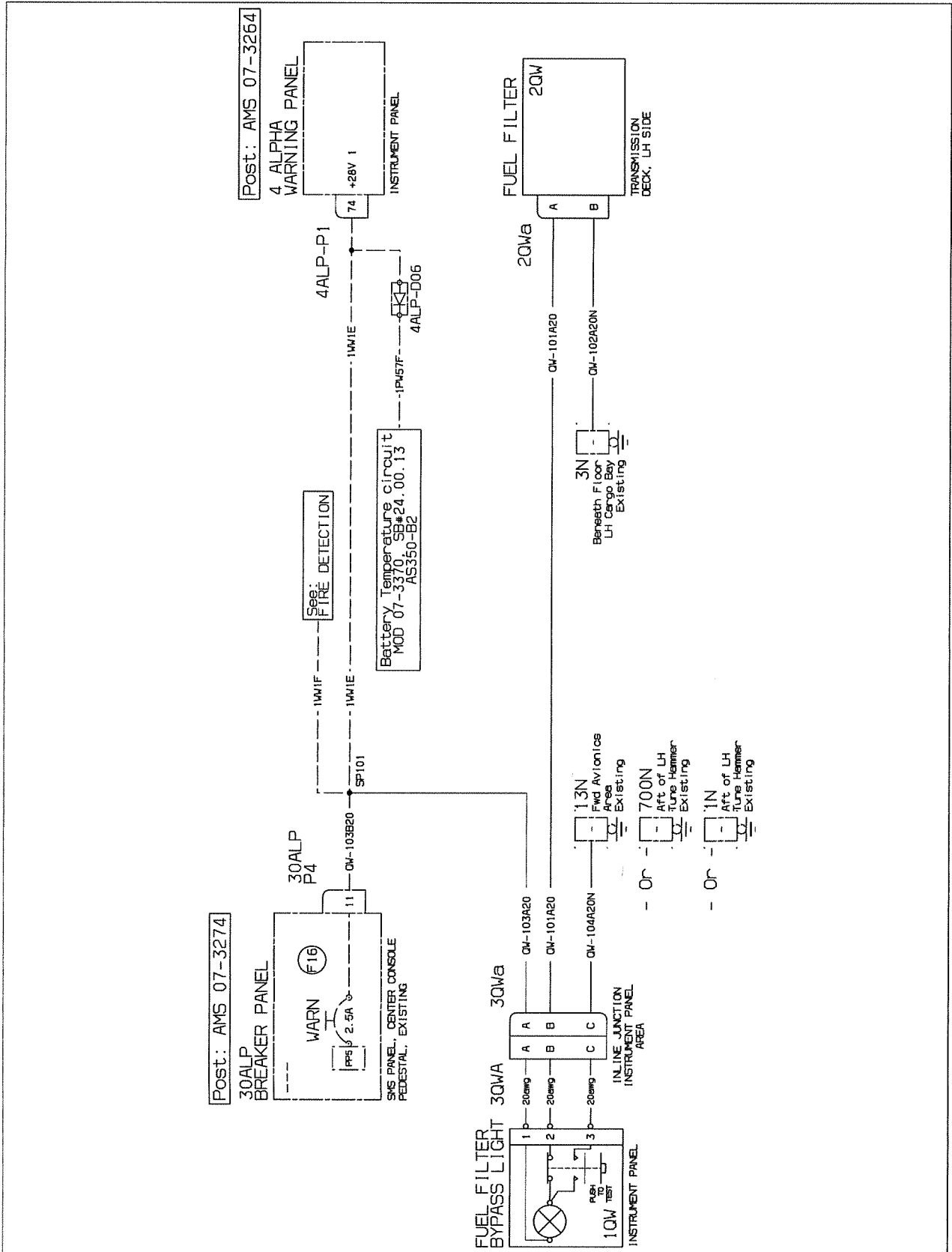

Figure 8 Airframe Fuel Filter, Wiring Diagram (aircraft with VEMD)

Transport Canada - Accepted

7. SPECIAL TOOLING

No special test equipment or tools are required. Standard tools are adequate.

8. REMOVAL AND REPLACEMENT

Proceed as follows if the fuel filter needs to be removed.

PRELIMINARIES

A. If modifying an AS 350 (excluding AS 350 B2/B3):

- Read the General Electrical Instructions (refer to AS 350 Maintenance Manual, Chapter 24.00.00.301)
- set the D.BAT" push button to "OFF"
- set the "EXT PWR BAT" pushbutton to "OFF" (refer to Electrical Power, AS 350 Maintenance Manual, Chapter 24.00.00.301)
- disconnect the external power unit and battery (refer to Removal/Installation, AS 350 Maintenance Manual, Chapter 24.30.00.401)
- Observe FUEL SYSTEM General Instructions - (Refer to AS 350 Maintenance Manual Chapter 28-00-00)

B. If modifying an AS 350 B2/B3:

- Read General Safety Instruction - Electrical Power Supply (refer to AS 350 B2/B3 Aircraft Maintenance Manual, Chapter 24-00-00, 3-1).
- Read Electrical Power Supply on the Ground (refer to AS 350 B2/B3 Aircraft Maintenance Manual, Chapter 24-00-00, 2-1)
- disconnect the external power unit and battery (refer to Removal/Installation, AS 350 B2/B3 Aircraft Maintenance Manual, Chapter 24-33-00, 4-1)
- Observe General Safety Instructions - Fuel System (refer to AS 350 B2/B3 Aircraft Maintenance Manual, Chapter 28-00-00, 3-1).
- Open the left MGB and engine cowling

A. REMOVAL

1) HOSES (For AS 350 B, BA, B1 and B2, refer to Figure 3) (For AS 350 B3, refer to Figure 5)

- a) Disconnect hose clamps (9) and spiral wrap if applicable and remove hose (19 a or b). Close hose end cover (10). Retain hose clamps (9), hose end covers (10) and spiral wrap for reinstallation. Refer to Figures 2 and 3.
- b) Remove packing (12) from elbow (11) and discard packing. Refer to Figure 2.

NOTE: If hose (19 a or b) are not being replaced, position hose out of work area and close hose end covers (10). Refer to Figure 2.

NOTE: Reuse clamps, hose end covers and spiral wrap from existing hose.

Transport Canada - Accepted

8. REMOVAL AND REPLACEMENT (continued)

A. REMOVAL (continued)

- 2) FUEL FILTER (For AS 350 B, BA, B1 and B2, refer to Figures 2 and 3) (For AS 350 B3, refer to Figures 4 and 5)
 - a) Disconnect hoses on either side of the Fuel Filter. Follow instructions given above.
 - b) Disconnect connector (7) and backshell (8) from fuel filter (2) and position wire out of working area. Refer to Figures 3 and 5.
 - c) Remove lockwire (4), screws (13, 3 places), and washers (14, 3 places) that secure the fuel filter (2) to top of fuel filter support assembly (1).
 - d) Remove fuel filter (2). Retain screws (13) and washers (14) for reinstallation.
- 3) FUEL FILTER WIRING
 - a) Remove damaged Airframe Fuel Filter wire or component.
- 4) FUEL FILTER SUPPORT ASSEMBLY, DOUBLER (For AS 350 B, BA, B1 and B2, refer to Figures 2 and 3)
 - a) Remove the Fuel Filter. Follow instructions given above.
 - b) Drill out rivets securing the fuel filter support assembly to the transmission deck. Discard damaged part. Refer to Figure 3.
 - c) Disconnect hose clamp (9) from funnel (23). Remove screws (13, 3 places), washers (14, 3 places) and nuts (3, 3 places) securing doubler (21). Discard damaged part.
 - d) If drain hose (16) is being replaced retain hardware. Refer to Figure 3.
- 5) DRAIN SUMP ASSEMBLY, DRAIN BRACKET, FLOOR DOUBLER, FUEL FILTER SUPPORT ASSEMBLY (For AS 350 B3, refer to Figures 4 and 5)
 - a) Remove the Fuel Filter. Follow instructions given above.
 - b) To remove the drain sump assembly (15) disconnect the hose clamp (16) and remove drain hose (17). Refer to Figure 4.
 - c) Remove drain bracket (13) from rear bulk head and discard. Retain grommet (14) for reinstallation.
 - d) If drain hose (17) is being replaced retain hardware. Refer to Figure 5.
 - e) Drill out rivets securing the fuel filter support assembly (1) to floor doubler (21). If replacing floor doubler (21), drill out rivets securing floor doubler (21) to the transmission deck. Discard damaged part. Refer to Figure 5.

Transport Canada - Accepted

8. REMOVAL AND REPLACEMENT (continued)

B. REPLACEMENT

NOTE Use torque per EC, MTC, Volume 2, Chapter 20.02.05.404, unless otherwise specified.

Safelying with Lockwire – refer to Safelying with Lockwire – MTC, Chapter 20-02-06-402.

Sealing compound PR-1422 B2 – refer to General methods for applying sealing compounds – MTC, Chapter 20.05.01.102 and Application of PR 1422 B sealant – MTC, Chapter 20-05-01-206.

Observe General Safety Instructions – Fuel System, refer to AS 350 (excluding B2/B3), MET, Chapter 28.00.00.301 for the AS 350 B2/B3, AMM, Chapter 28-00-00, 3-1.

Electrical Bonding – refer to Electrical Bonding – General, MTC, Chapter 20.02.07.101.

- 4) FUEL FILTER SUPPORT ASSEMBLY, DOUBLER (For AS 350 B, BA, B1 and B2, refer to Figures 2 and 3)
 - a) Position doubler (21) and over hole in transmission deck and place funnel (23) into hole. Mark mounting hole locations from funnel (23) into doubler (21). Drill mounting holes and deburr. Refer to Figure 3.
 - b) Install screen (22), doubler (21), and funnel (23) and secure using screws (13), washers (14) and nuts (3). Surface treat all holes and edges. Seal all around with sealant (24).
 - c) Position new fuel filter support assembly (1) onto transmission deck and secure into place using rivets (25). Secure all around fuel filter support assembly (1) with sealant (24).
- 5) DRAIN SUMP ASSEMBLY, DRAIN BRACKET, FLOOR DOUBLER, FUEL FILTER SUPPORT ASSEMBLY (For AS 350 B3, refer to Figures 3, 4, 5 and 6)
 - a) If replacing drain bracket (13), position drain bracket (13) onto rear bulkhead and secure using rivets (5 places [MS20470AD]) and reinstall grommet (14). Refer to Figure 3.
 - b) Position new floor doubler (21) onto transmission deck. Align opening and existing rivet holes. Temporarily secure to the transmission deck and match drill existing holes from the transmission deck into the floor doubler (21). Deburr holes.
 - c) Position base (19) onto floor doubler (21). If replacing base (19), match drill holes from floor doubler (21) into base (19) as shown in Figure 6.
 - d) If replacing drain sump assembly (15), temporarily position drain sump assembly (15) onto base (19) and match drill 4 pilot holes from base into drain sump assembly. Refer to Figure 4.
 - e) If replacing fuel filter support assembly (2) temporarily position fuel filter support assembly (2) onto base (19) and match drill holes from base.
 - f) Remove fuel filter support assembly (2), drain sump assembly (15), base (19), and floor doubler (21) and deburr all newly drilled holes.
 - g) Reposition floor doubler (21) onto transmission deck start securing into place using rivets. Refer to Figure 6.
 - h) Reposition base (19) onto floor doubler (21) and seal faying surfaces with sealant (25) and secure using rivets. Follow rivet chart shown in Figure 6.
 - i) Fillet seal edges of floor doubler (21) to transmission deck using sealant (25).
 - j) Position drain sump assembly (15) and secure using screws (7), washers (8) and nuts (20). Refer to Figure 4.

Transport Canada – Accepted

8. **REMOVAL AND REPLACEMENT** (continued)

B. **REPLACEMENT**

- k) Seal faying surface of drain sump assembly (15) using sealant (21).
- l) Secure fuel filter support assembly (1) onto base using rivets (MS20470AD).
- m) Position plate onto fuel filter support assembly (1) and secure using rivets

NOTE: Do not seal between plate (26) and drain sump assembly (15).

- n) Position the fuel filter (2) in the top angle of the fuel filter support assembly (1). Secure into place using washers (14), and screws (13). Torque screws to required specification and secure with lockwire (4). Refer to Figure 2. Refer to Safelying with Lockwire, MTC, Chapter 20-02-06-402.

6) **HOSES**

NOTE: Reuse clamps, hose end cover and spiral wrap from existing hose.

NOTE: Apply grease (23) to the nipple of the elbow (11) and to the inside diameter of the hoses (19 a and b) before installation. Refer to Figure 5.

NOTE: To avoid any low or high spots in the routing of the fuel line hoses (19 a or b) and to produce the least strain on the hoses, adjust the angle of elbows (11).

- a) If replacing either hose from fuel filter, repack FWD elbow (12) with packing (2 b).
- b) If replacing hose (19 a), install existing hose end cover (10) into one end of hose (19 a). Connect hose to FWD elbow (11) on the fuel filter. Hose end cover (10) to be opened up to fit elbow (11).
- c) Trim opposite end of hose (19 a) to the required length to connect it to the existing fuel shut off hose. Install existing hose cover (10) into end of hose and secure to fuel shut off hose. Refer to Figure 5.
- d) Install spiral wrap on hose (19 a) at point of contact with hose clamp (9).
- e) If replacing hose (19 b), route the hose (19 b) from the fuel tank, through the existing grommet in the transmission deck.
- f) Install the hose end cover (4) into the hose (19 b), connect the hose to the AFT elbow (11). Hose end cover (10) to be opened up to fit aft elbow (11).
- g) Once hoses are adjusted secure using clamps (7).
- h) If replacing drain hose (20), connect the drain hose (20) to the drain sump assembly (15) and secure using hose clamp (16). Route hose through grommet (14) in drain bracket (13). Refer to Figure 4.
- i) Place spacer (16) between existing fuel line drain hose (20) and secure to existing fuel line using two ty-raps (15). Refer to Figure 5.
- j) Route the drain hose (13) along to existing fuel line.
- k) Run drain hose (20) through existing grommet in belly panel and trim hose as required.
- l) Install new identification tag on replaced hose (19 a and b) and (20).

Transport Canada - Accepted



- 7) FUEL FILTER (For AS 350 B, BA, B1 and B2, refer to Figure 3) (For AS 350 B3, refer to Figure 5)
 - a) Position fuel filter (2) into filter support assembly (1) and secure using previously removed screws (13, 3 places), and washers (14, 3 places). Torque screws to required specifications and secure using lockwire (4).
 - b) Repack elbow (11, 1 place) on LHS of fuel filter (2) with new packing (6, 1 place). Reconnect hose (19 b) to elbow (4) and secure reusing hose clamps (6, 2 places).
 - c) Repack elbow (11, 1 place) on RHS of fuel filter (2) with new packing (6, 1 place). Reconnect hose (19 a) to elbow (11) and secure reusing hose clamps (9, 2 places).

NOTE Apply grease (23) to the nipple of elbows (11, 2 places) and to the inside diameter of the hoses (19 a and b places) before installation.

- d) Attach the backshell and connector to the top of the fuel filter.

If a new fuel filter has been installed, ensure ident label, shown in Figure 7 is installed facing outboard after fuel filter installation.

8) FUEL FILTER WIRING

- a) Refer to Airframe Fuel Filter wiring drawings in this document to replace damaged components or wiring.
 - b) Install in accordance with AC43.13-1B, Chapter 11.
 - c) Check electrical bonding in accordance with AC 43.13-1B, Chapter 11, Section 15, Paragraph 11-189.
- 9) Check After Maintenance Work - Fuel System in accordance with AS 350 B2/B3, Chapter 28-00-01, 6-2.
 - 10) Install the Purolator Dummy Filter Test Element (P/N 1741185), as per this document, and using the Purolator Operating Instruction for the filter assembly contained in this document in Appendix A, check for the correct operation of the fuel filter bypass function.
 - 11) Install the fuel filter element, and perform a leak check with boost pump(s) on.
 - 12) Close all areas opened for service in the PRELIMINARIES paragraph of this section.

AS 350 (excluding AS 350 B2/B3):

- 1) Apply external power unit and battery. Refer to AS 350 Maintenance Manual, Chapter 24.30.00.401.
- 2) Perform functional test in accordance with AS 350 Aircraft Maintenance Manual, Chapter 24.30.00.501.

AS 350 B2/B3:

- 1) Before energizing the aircraft power supply system, read Safety Instructions (refer to General Safety Instruction - Electrical Power Supply System, AS 350 B2/B3 Aircraft Maintenance Manual, Chapter 24-00-00, 3-1).
 - 2) Reconnect the external power unit and battery (refer to Removal/Installation AS 350 B2/B3 Aircraft Maintenance Manual, Chapter 24-33-00, 4-1).
 - 3) Perform functional test - DC Power Supply System in accordance with AS 350 B2/B3 Aircraft Maintenance Manual, Chapter 24-30-00, 5-1.
- 12) Close left MGB and engine cowlings.

Transport Canada - Accepted

9. WEIGHT AND BALANCE

For AS 350 B, BA, B1, B2

A. Removed Items

DESCRIPTION	WEIGHT		ARM		MOMENT	
	kg	lbs	m	in	kg m	lb in
(not applicable)	0.00	0.0	0.00	0.0	0.00	0.0
Total	0.00	0.0	0.00	0.0	0.00	0.0

B. Added Items

DESCRIPTION	WEIGHT		ARM		MOMENT	
	kg	lbs	m	in	kg m	lb in
Air Frame Fuel Filter	0.97	2.1	3.46	136.3	3.37	286.2
Fuel Filter Support Assembly	0.39	0.9	3.46	136.3	1.36	122.7
Hardware and Harness	1.00	2.2	3.46	136.3	3.46	299.9
Total	2.37	5.2	3.46	136.3	8.19	708.8

For AS 350 B3 (POST SB-ECL-109)

A. Removed Items

DESCRIPTION	WEIGHT		ARM		MOMENT	
	kg	lbs	m	in	kg m	lb in
Transmission Deck Cut-out	0.09	0.2	3.50	137.7	0.31	27.54
Total	-0.09	-0.2	3.50	137.7	-0.31	-27.54

B. Added Items

DESCRIPTION	WEIGHT		ARM		MOMENT	
	kg	lbs	m	in	kg m	lb in
Airframe Fuel Filter	0.91	2.0	3.50	137.8	3.19	275.6
Fuel Filter Support Assembly	0.28	0.6	3.50	137.8	0.98	82.7
Hardware and Harness	2.25	5.0	3.50	137.8	7.88	689.0
Total	3.44	7.6	3.50	137.8	12.04	1047.3

Transport Canada - Accepted

10. **PLACARDS AND MARKINGS**

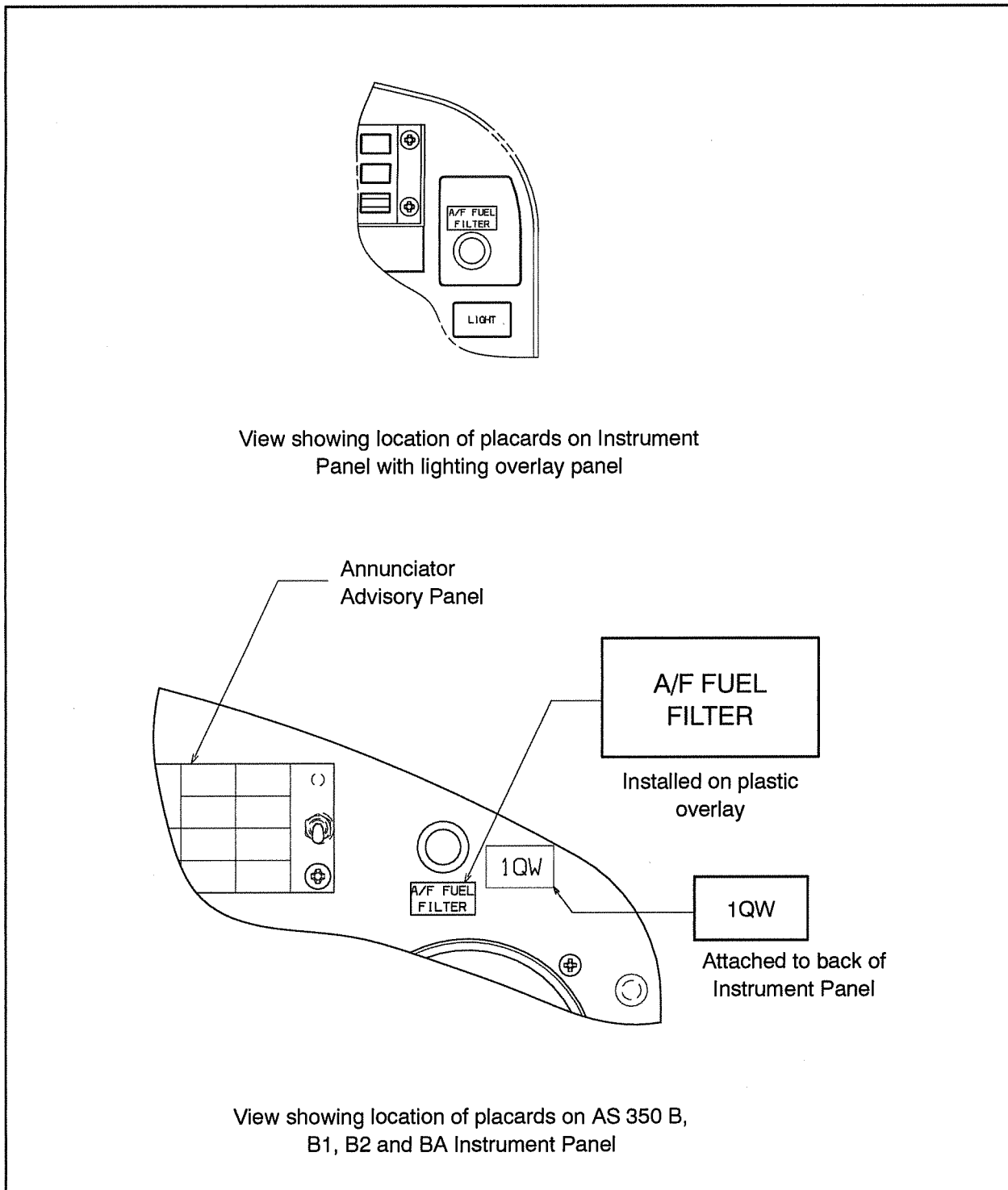

Figure 9 Identification labels on Instrument Panels (excluding AS 350 B3)

Transport Canada - Accepted

10. **PLACARDS AND MARKINGS** (continued)

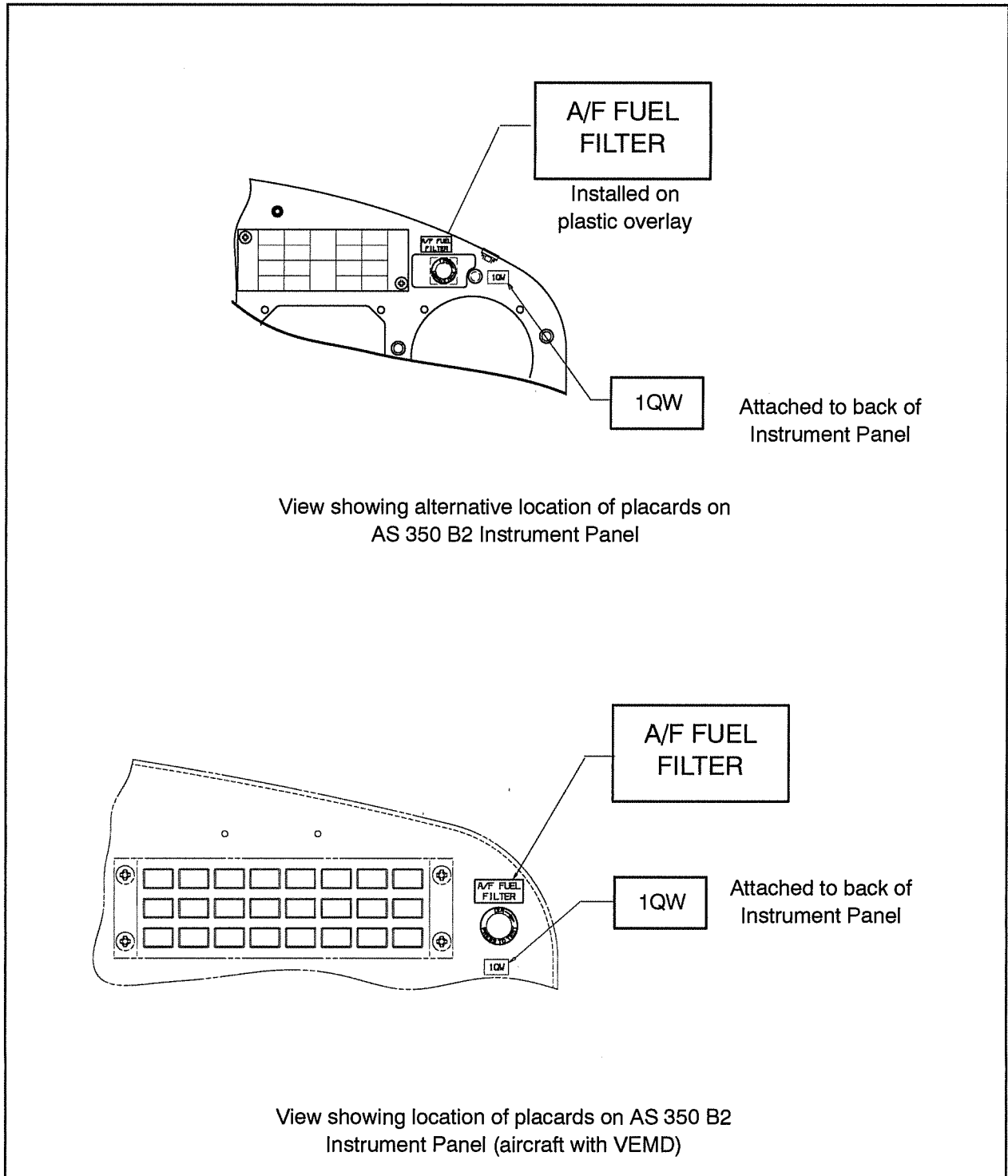

Figure 10 Identification labels on AS 350 B2 Instrument Panels

Transport Canada - Accepted

10. **PLACARDS AND MARKINGS** (continued)

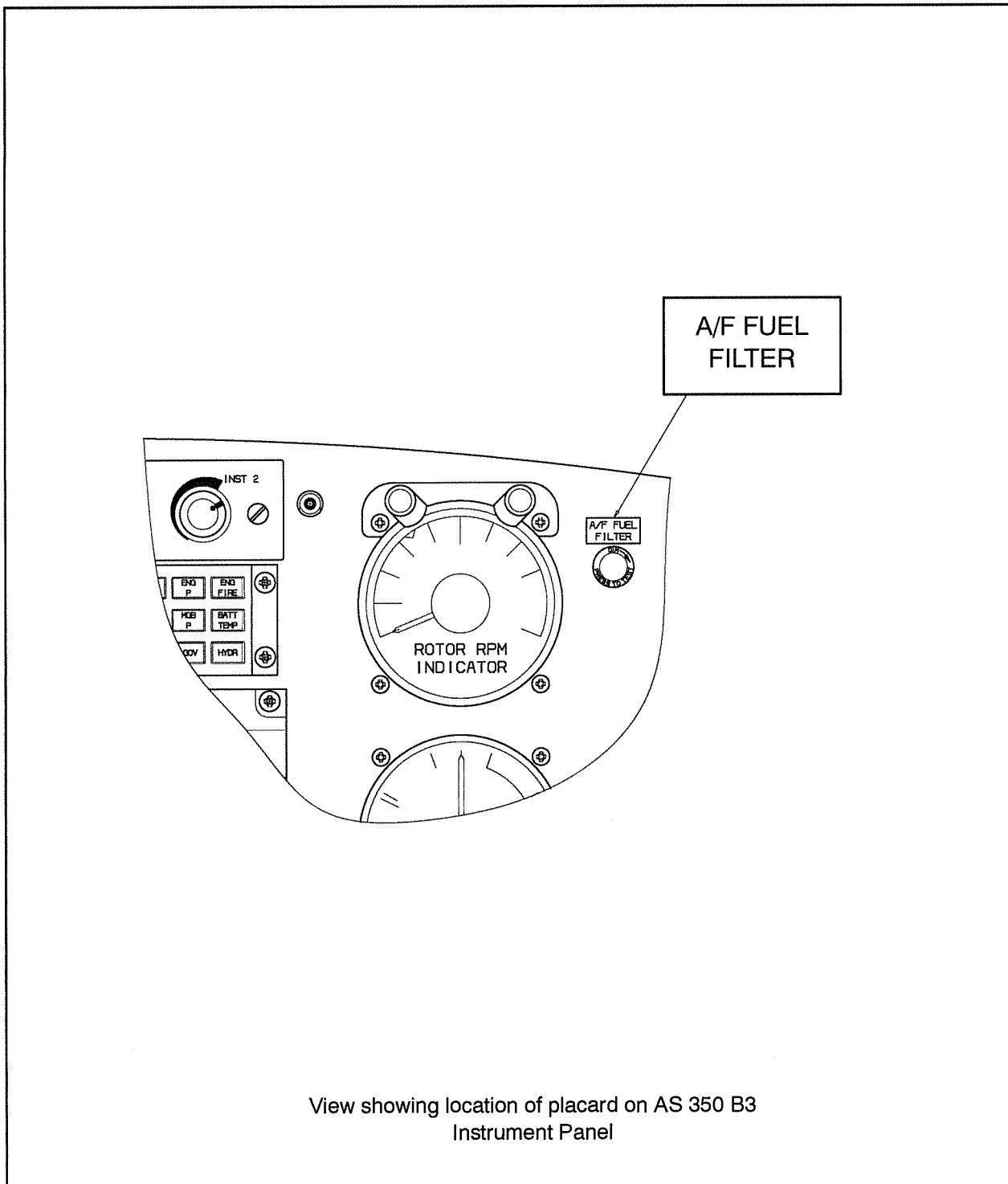

Figure 11 Identification labels on AS 350 B3 Instrument Panels

Transport Canada - Accepted

10. **PLACARDS AND MARKINGS** (continued)

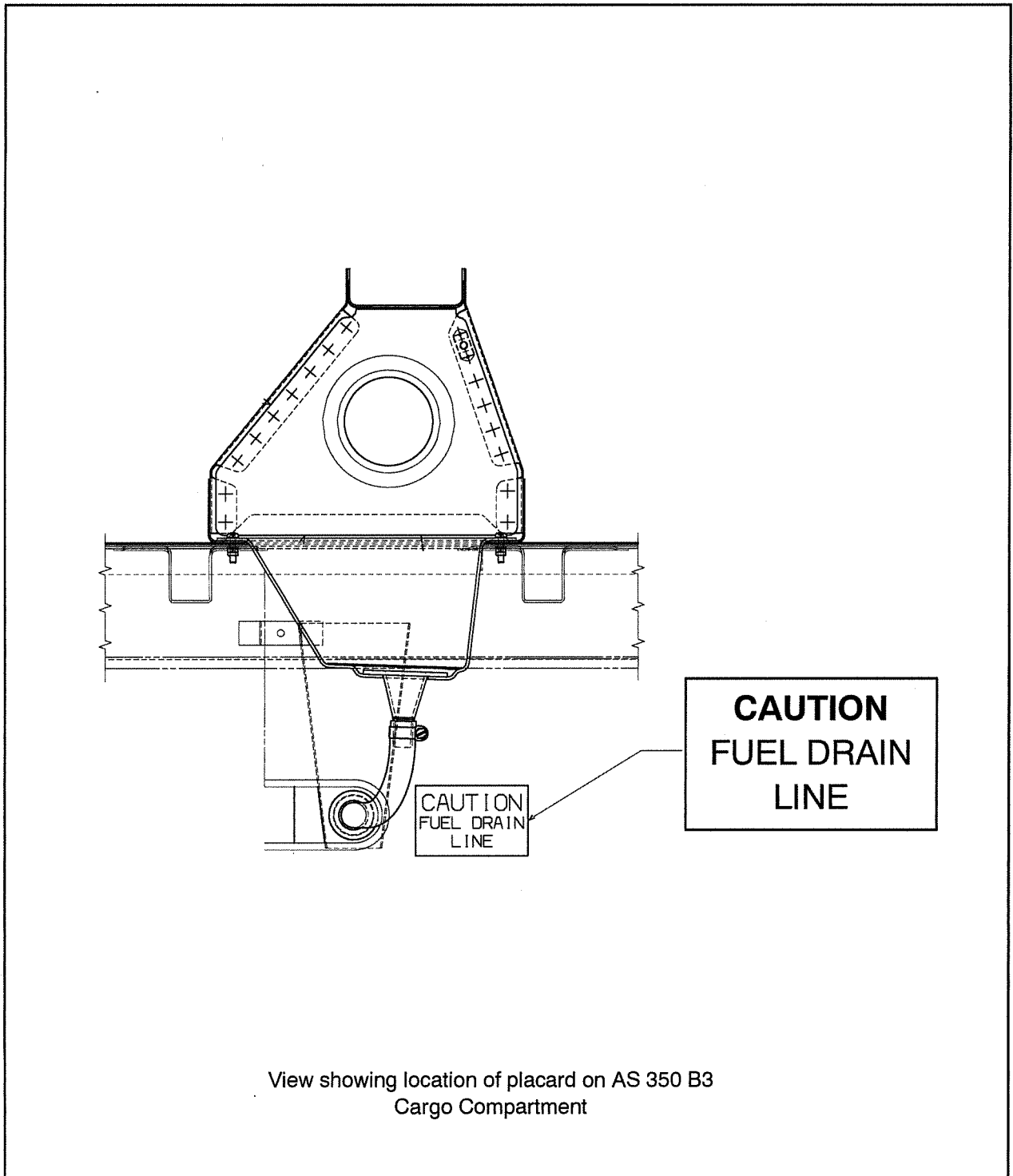
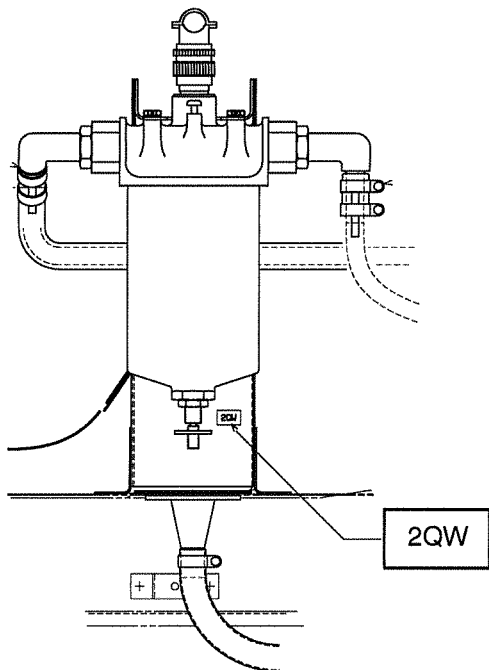

Figure 12 Placard in AS 350 B3 LH Cargo Compartment

Transport Canada - Accepted

10. **PLACARDS AND MARKINGS** (continued)



View showing location of placard on
AS 350 B, BA, B1 and B2 Fuel Filter
Support Assembly

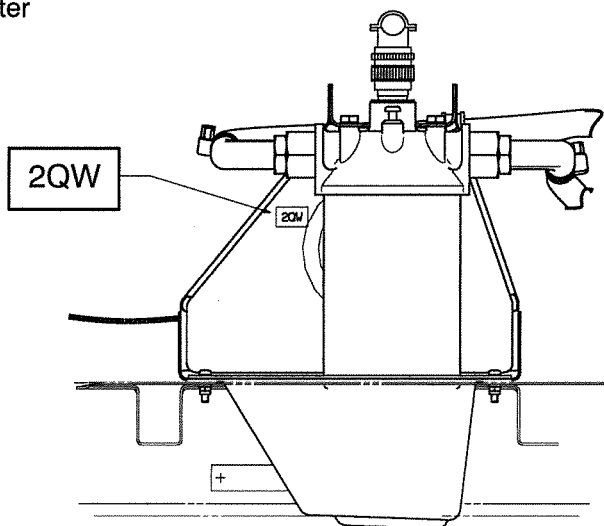

View showing location of placard on AS 350 B3
Fuel Filter Support Assembly

Figure 13 Typical label location for the Fuel Filter Support Assembly

Transport Canada - Accepted



10. **PLACARDS AND MARKINGS** (continued)

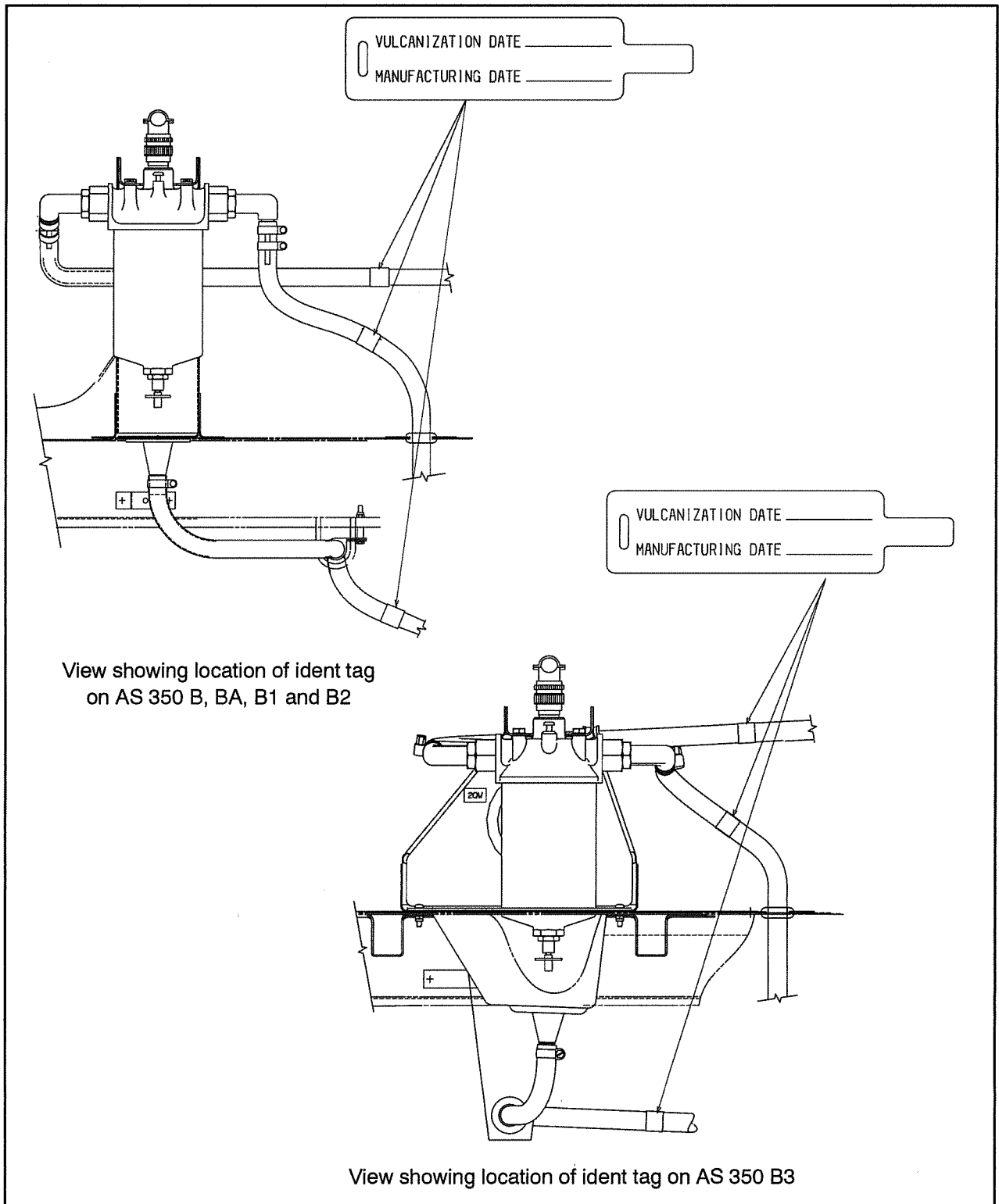

Figure 14 Identification Tags on hoses

Transport Canada - Accepted



**Operating & Design Specifications
Fuel Filter Assembly
Part No.: 1743640-01**

Purolator Facet Inc.
8439 Triad Drive, Greensboro, NC 27409-9621
Phone: (336) 668-4444, Fax (336) 668-4452

Purolator Fuel Filter Assembly Part No. 1743640-01

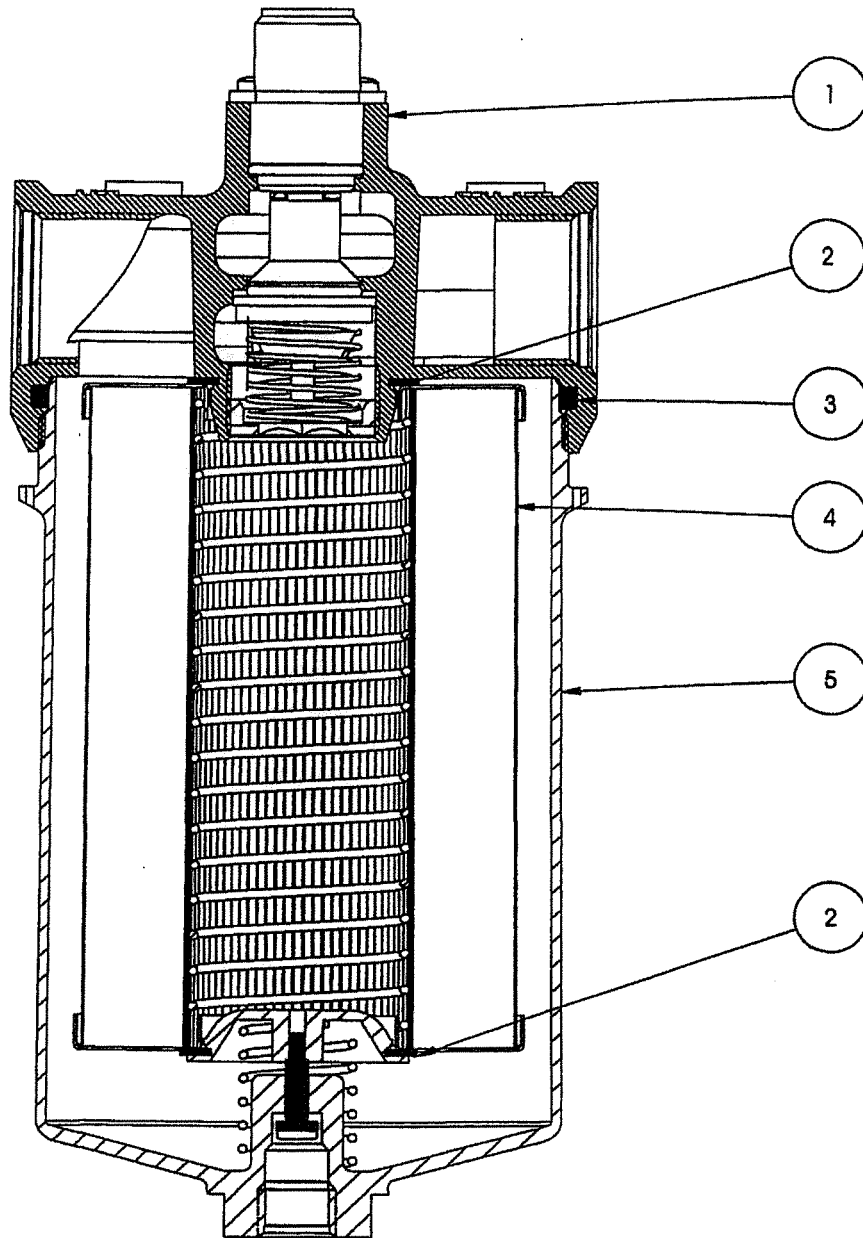

Replacement Parts for Filter Assembly Part No. 1743640-01

Item No.	Qty. Req.	Part No.	Description:
1.	1	1744990-01	Head Assembly
2.	2	1743629-01	Seal
3.	1	034921-01	O-Ring
4.	1	1743645-01	Element Assembly
5.	1	1745011	Bowl Assembly

NOTE: Purolator replacement element kit part no. 1743645-02 consists of items 2, 3 & 4

Operating Instructions:

Preflight Inspection Procedure Change:

1. Follow aircraft manufacturers recommended preflight instructions.
-

Scheduled Maintenance:

1. Fuel Filter Element Change:
 - A. Replace element at the intervals specified by the aircraft manufacturer.
 - B. Remove lockwire and unscrew filter bowl.
 - C. Remove used element.
 - D. Remove O-Ring and flat seals from filter head and inside of bottom of filter bowl.
 - E. Install new seals P/N: 1743629-01 on the nipple of the filter head and retainer in the filter bowl.
 - F. Install new filter element p/n: 1743645-01.
 - G. Install new O-Ring P/N: 034921-01 in the filter head.
 - H. Re-install filter bowl and torque to 130±20 inch pounds.
 - I. Secure filter head to filter bowl with lockwire.

**Purolator Fuel Filter Assembly
Part Number 1743640-01**

Design Specifications:

1. Filtration Rating: 10 Micrometres Nominal
2. Fluid: Mil-T 5624 Gr. JP-4, JP-5, ASTM-D-1655 Type A, A1 or B.
3. Temperature Range: -65°F to +160°F.
4. Bypass valve cracking Pressure: 3.75 PSID.
5. Microdelta® Differential Pressure Switch actuates at 0.875 PSID
7. Pressures: Operating: 60 PSI
 Proof: 90 PSI
 Burst: 180 PSI
8. Rated Flow: 0.5 GPM
9. Weight: 1.75 lbs. Max.