



Building the Third Golden Age of Aerospace

Airbus Media Day

Paul Eremenko, CTO
09 June 2017

AIRBUS

Technology curve framework

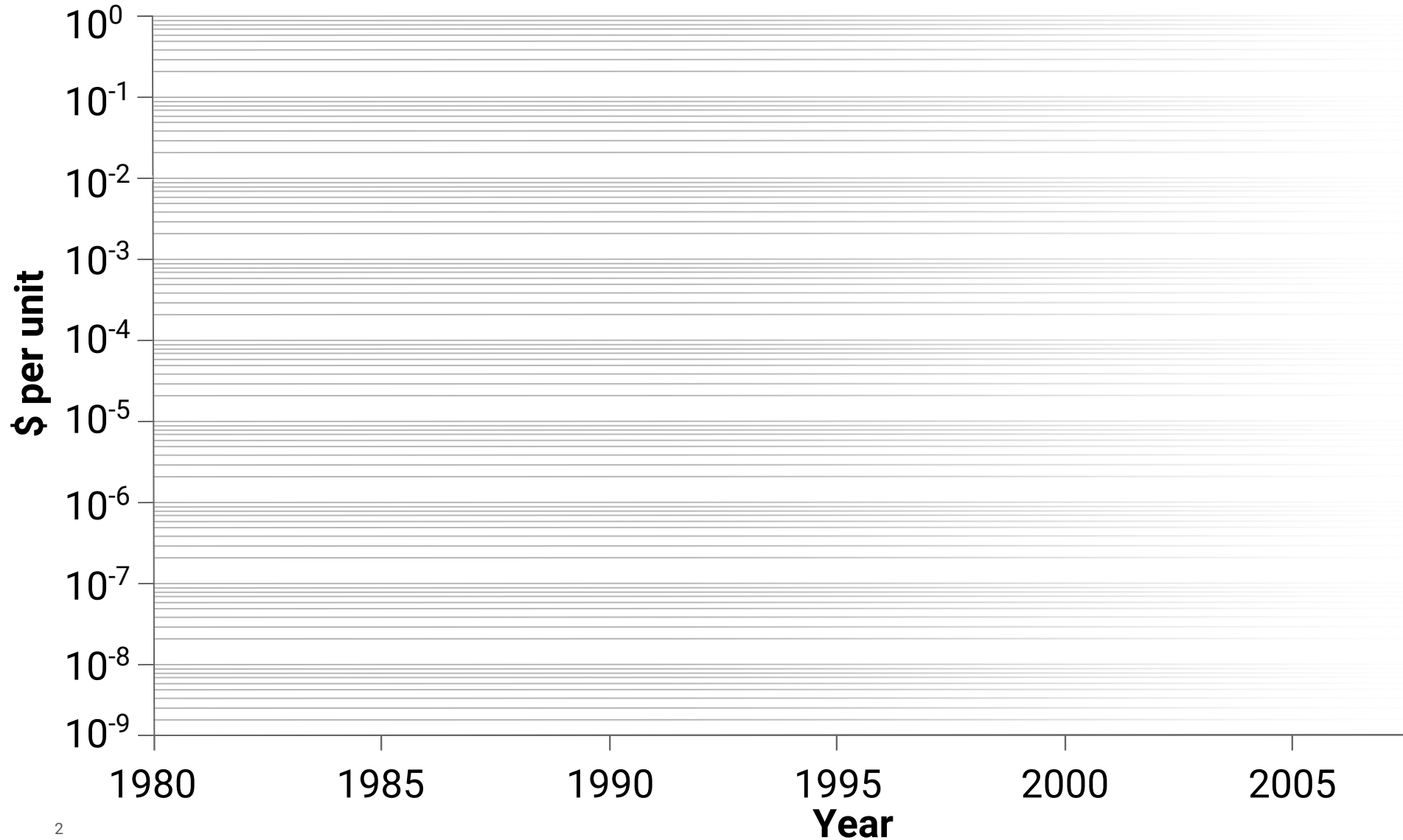

Bits: Integrated circuits

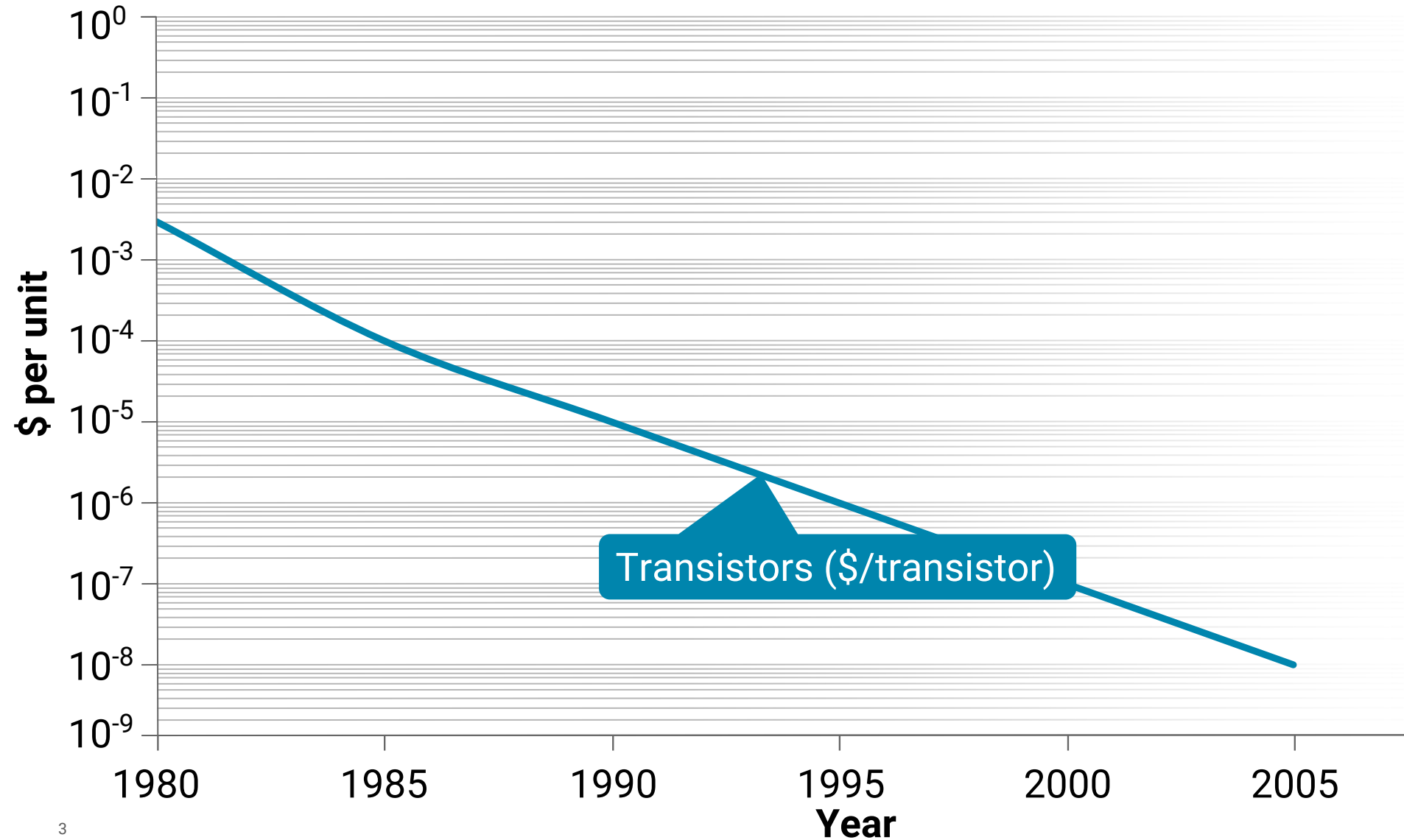

Bits: Memory storage

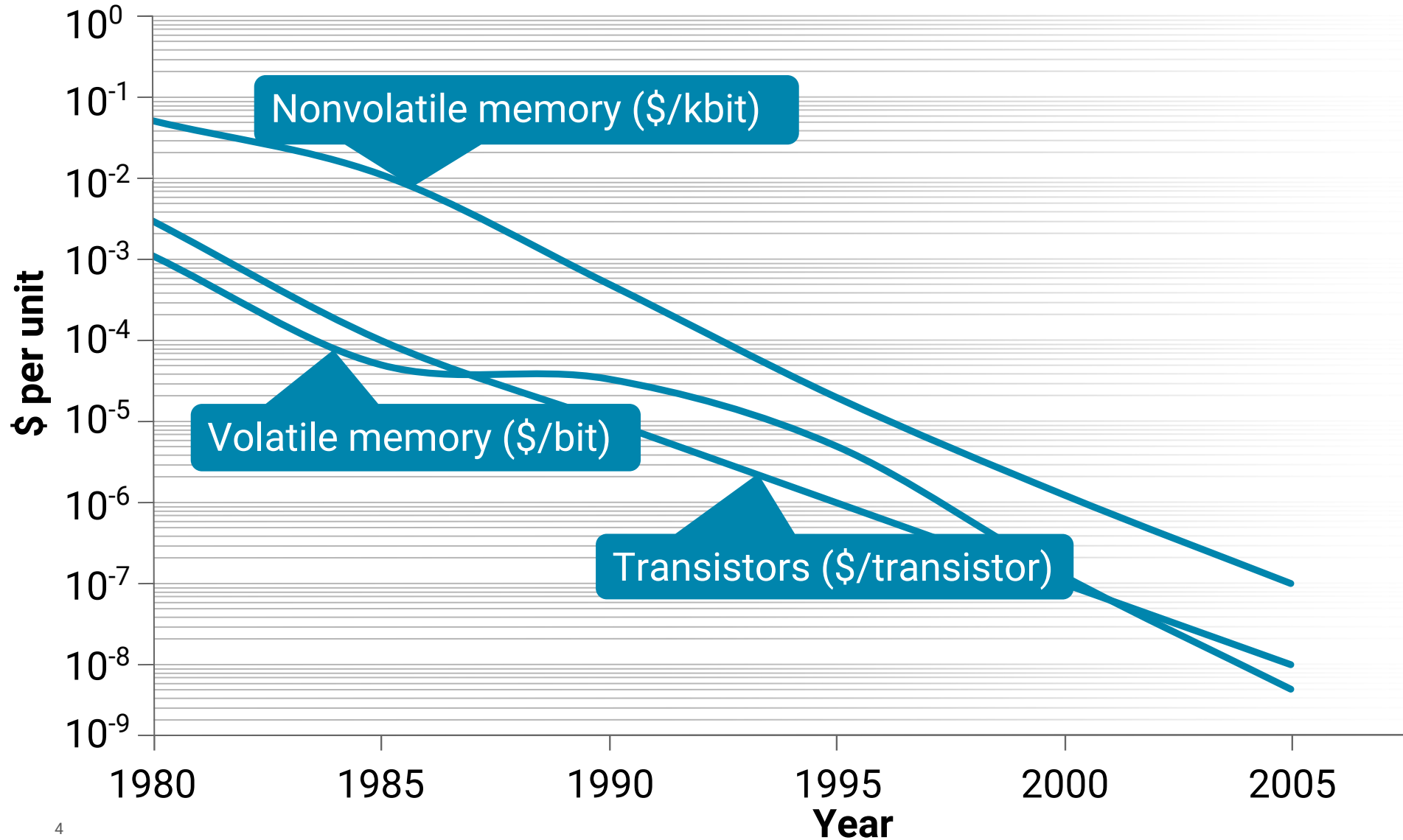

Bits: Camera CCDs

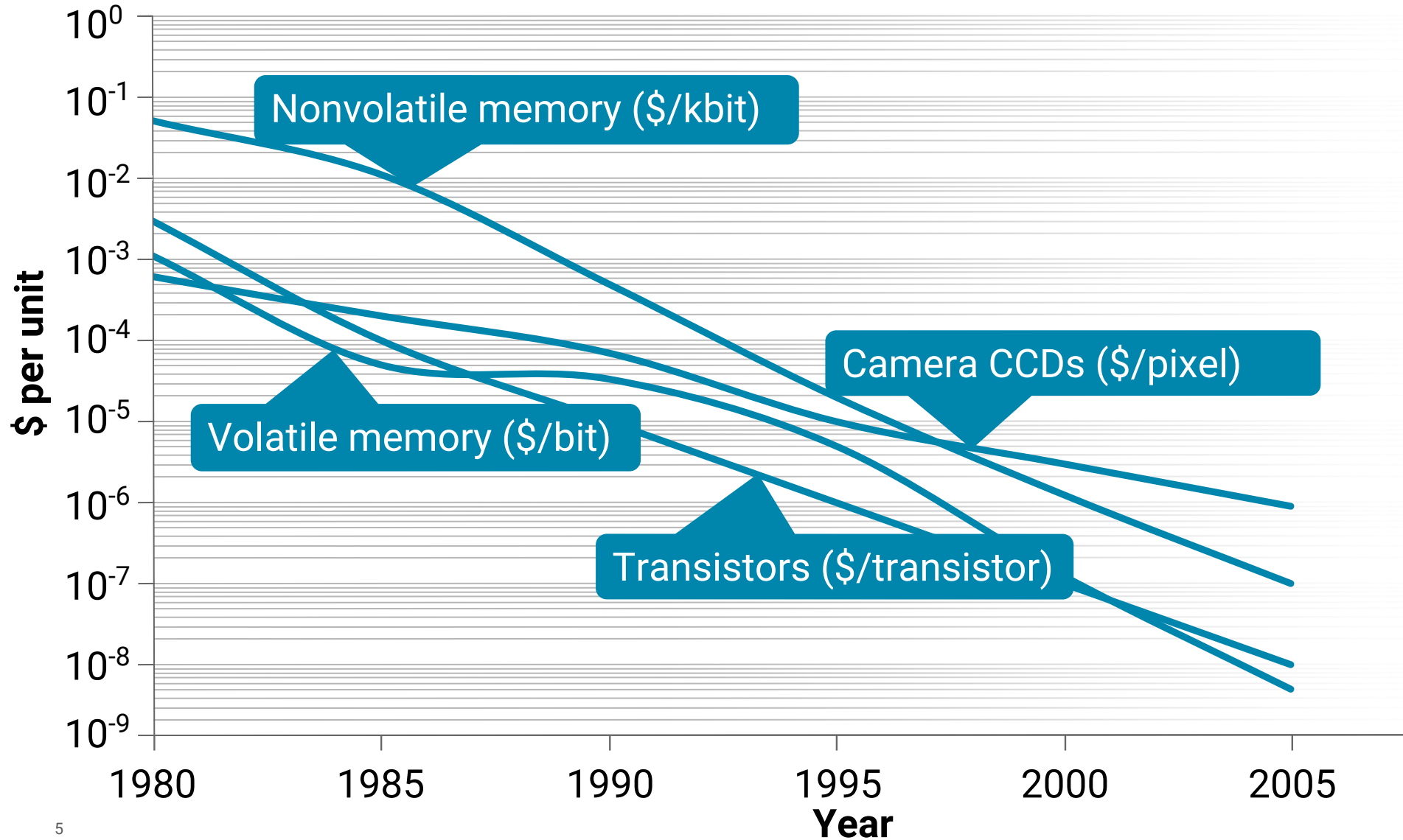

Bits: Wireless communications

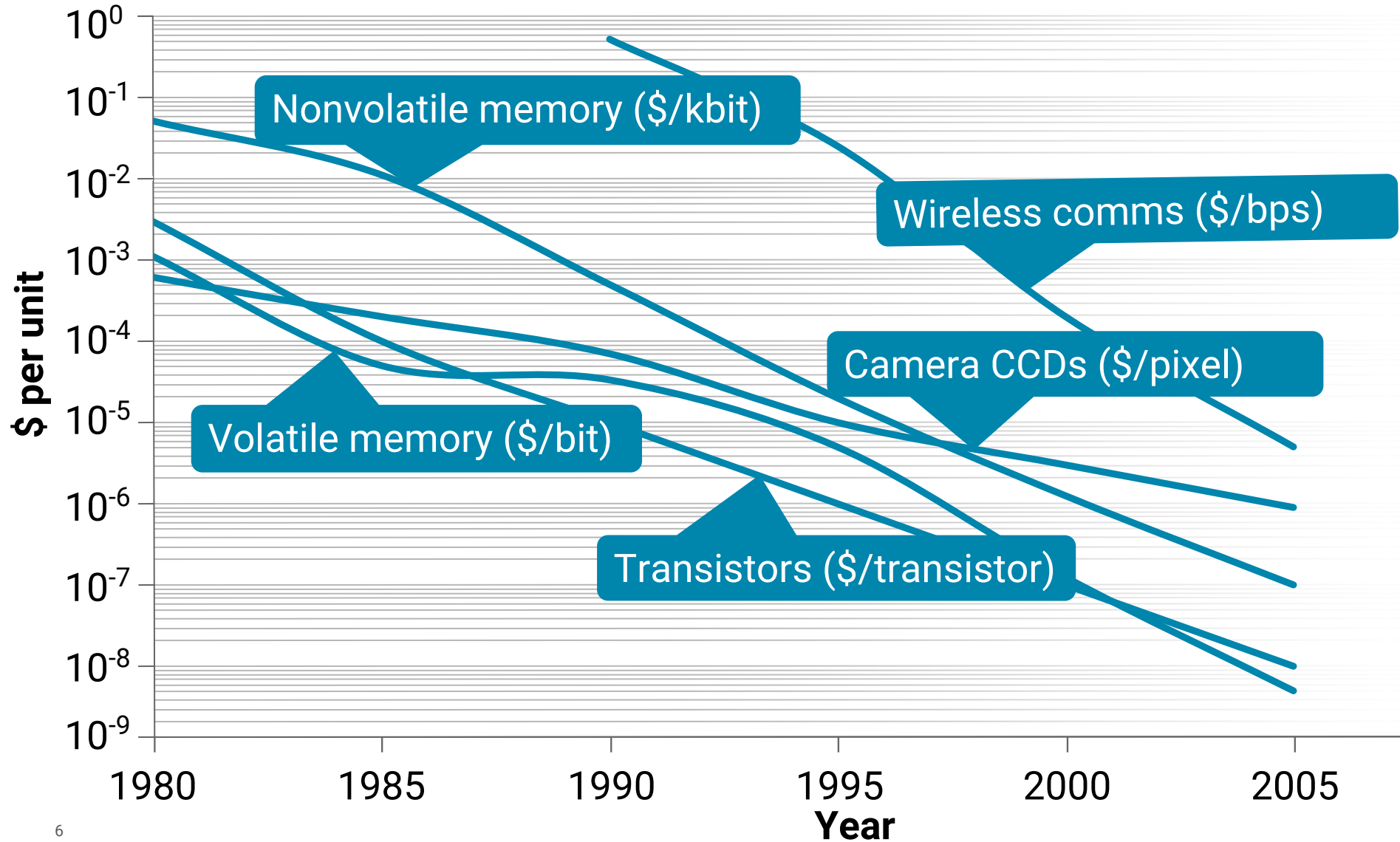

Voilà: The smartphone

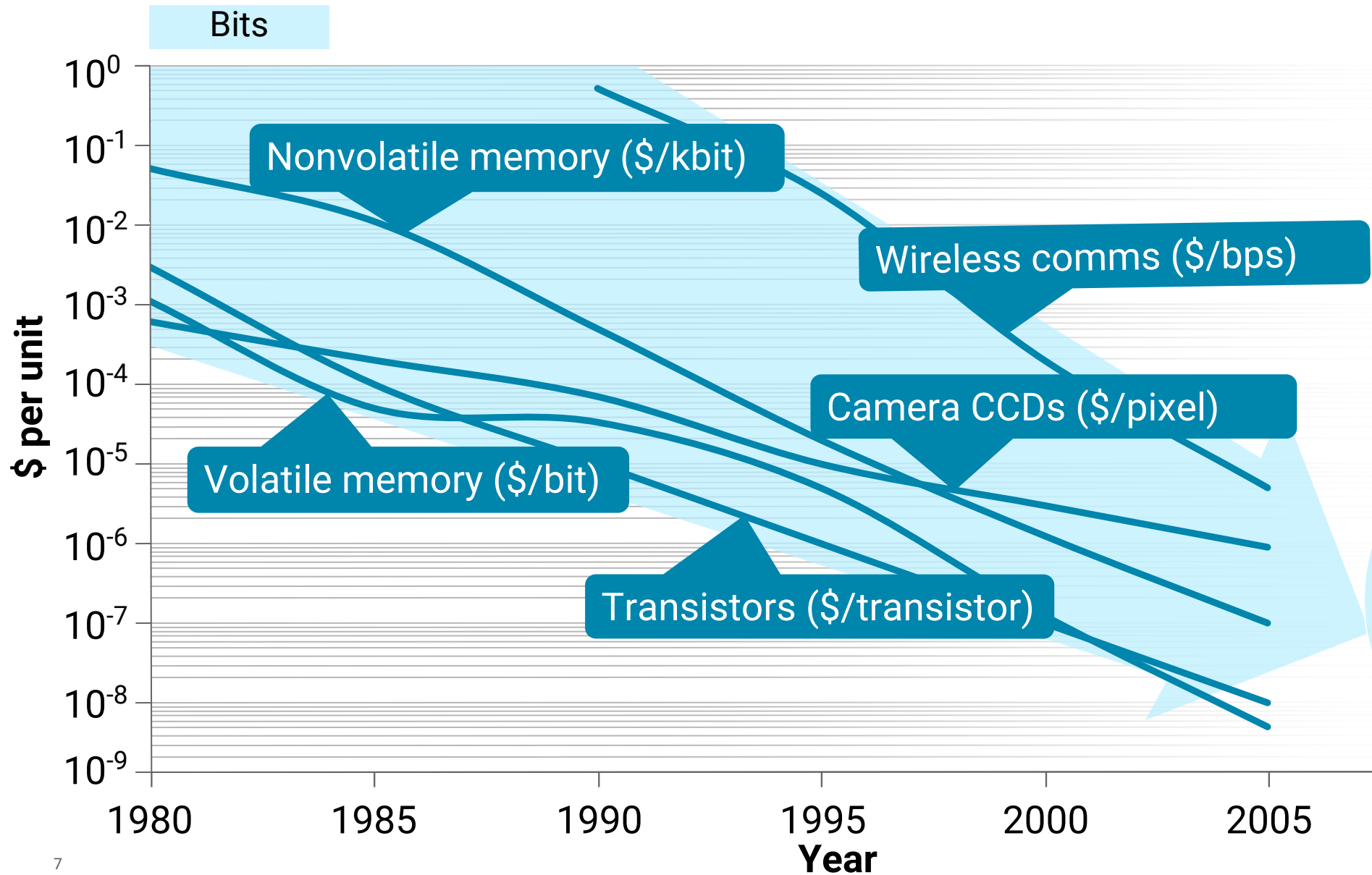

Electrons: Batteries

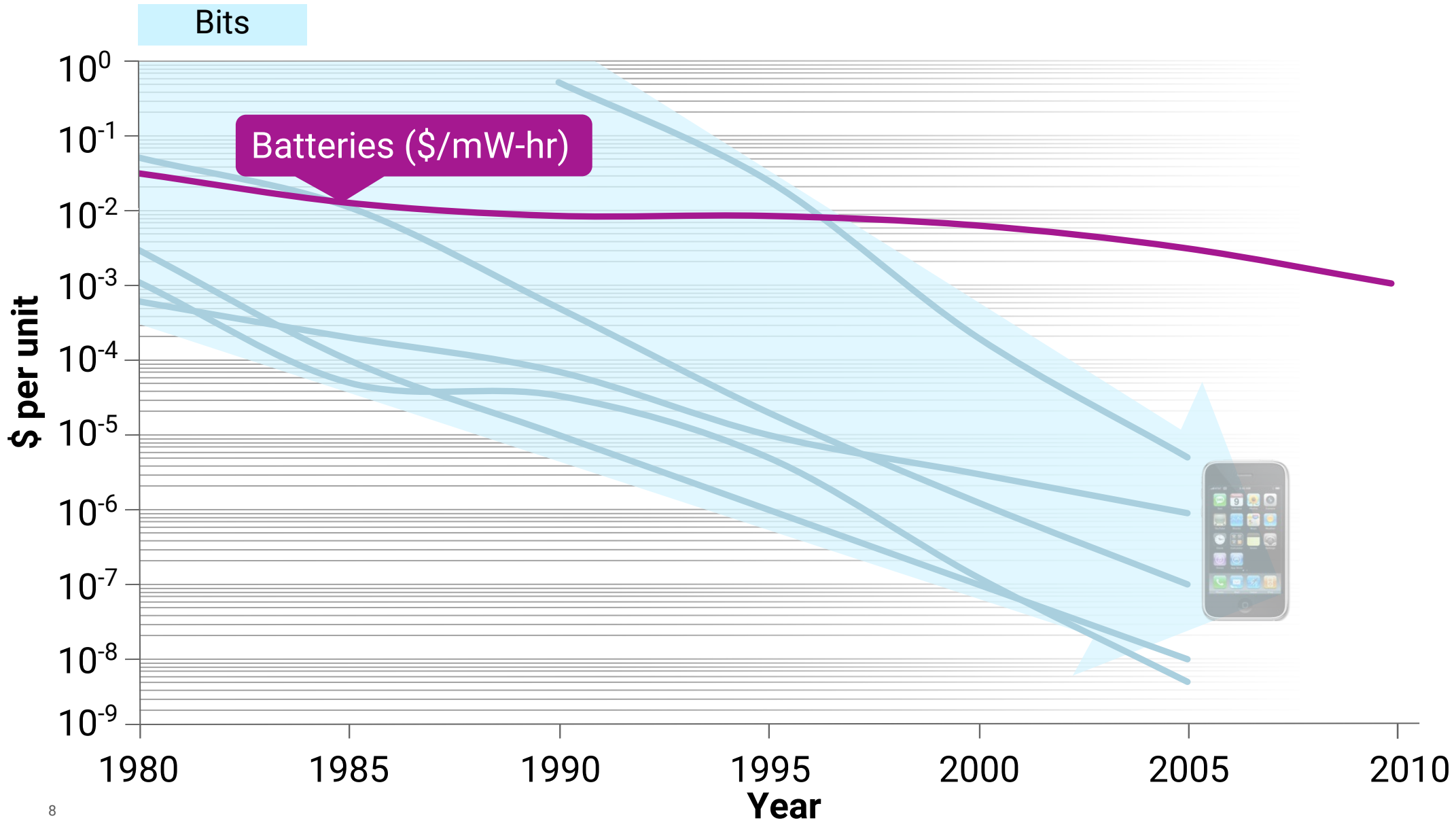

Electrons: Photovoltaics

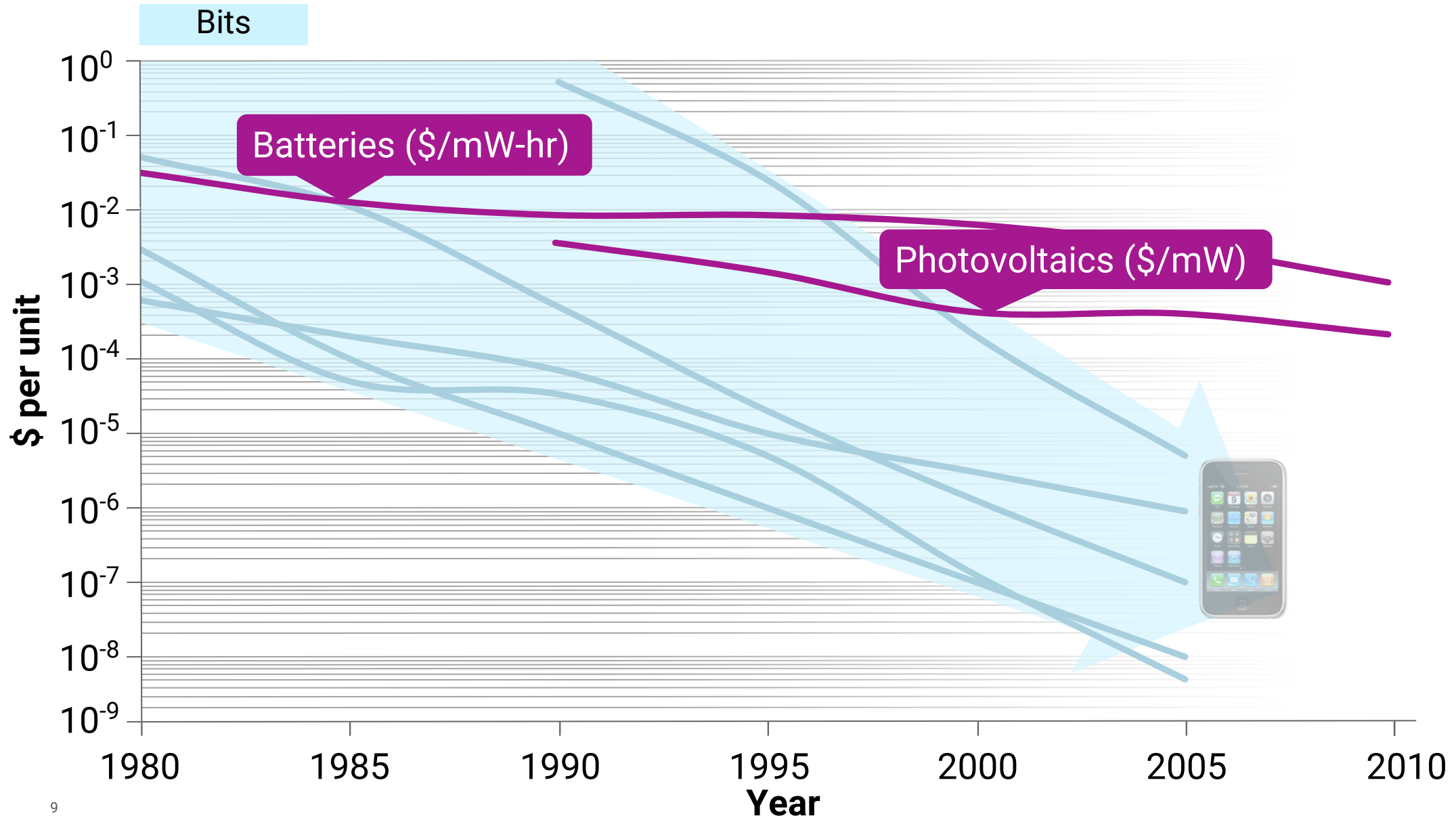

Voilà: Cubesats & quadcopter drones

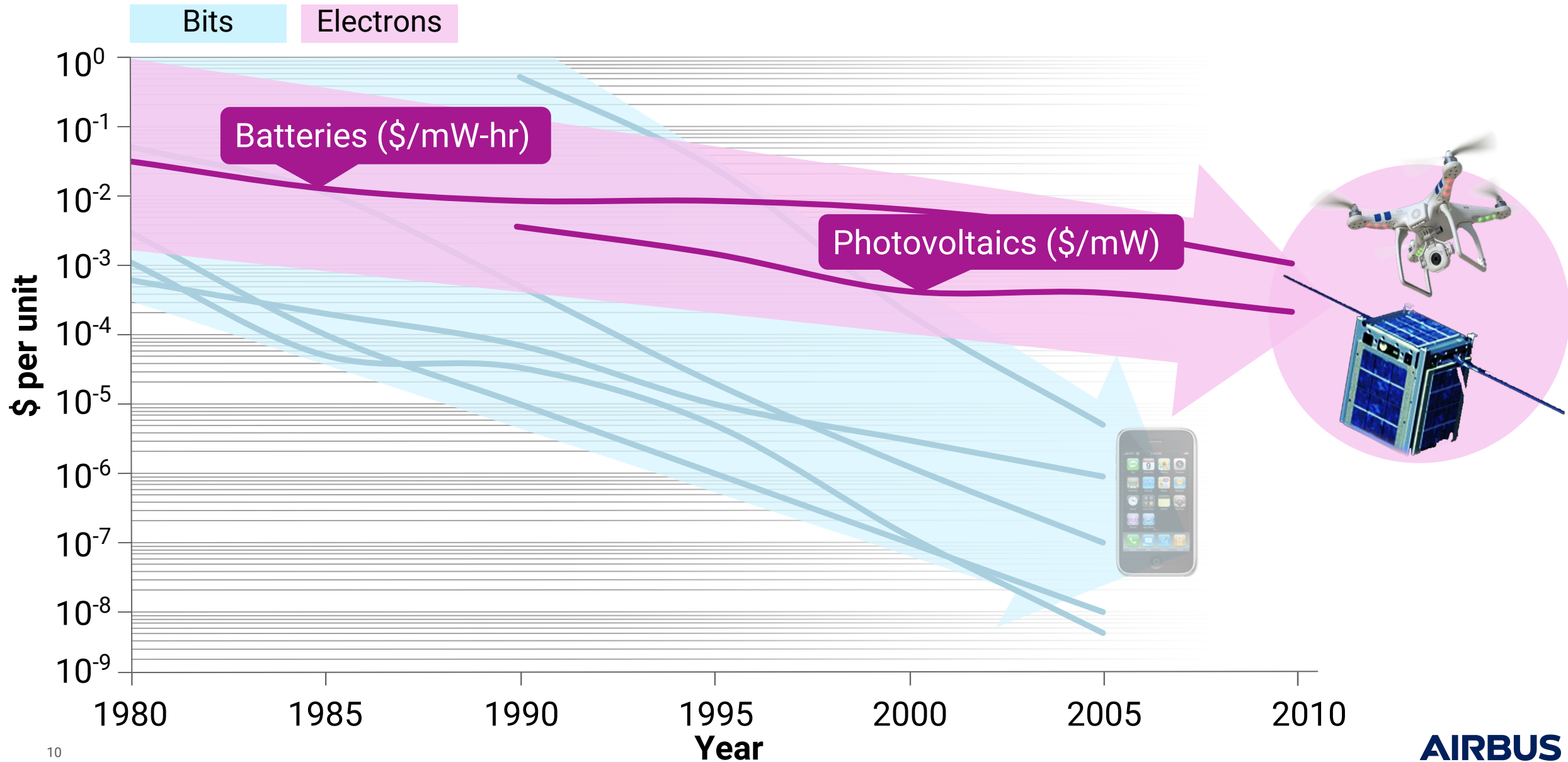

Lowering the barrier to entry

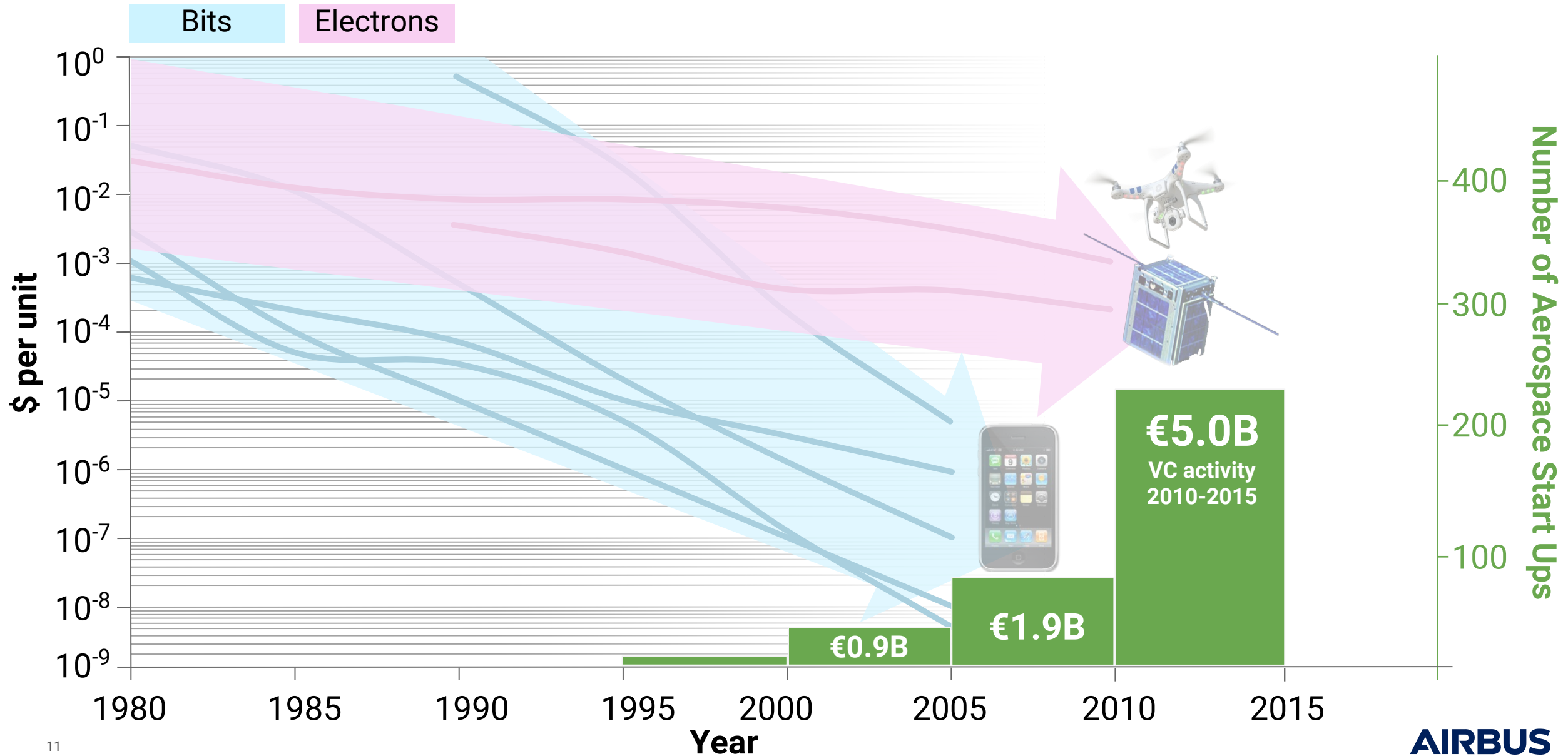

What the new entrants are working on



SpaceX



Bigelow



E-Hang



Boom



Wright Electric

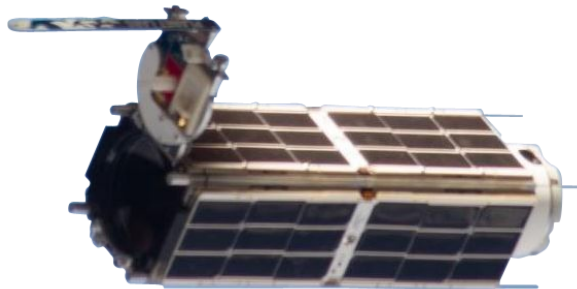

PlanetLabs



Amazon



Zunum

Atoms: Manufacturing robotics

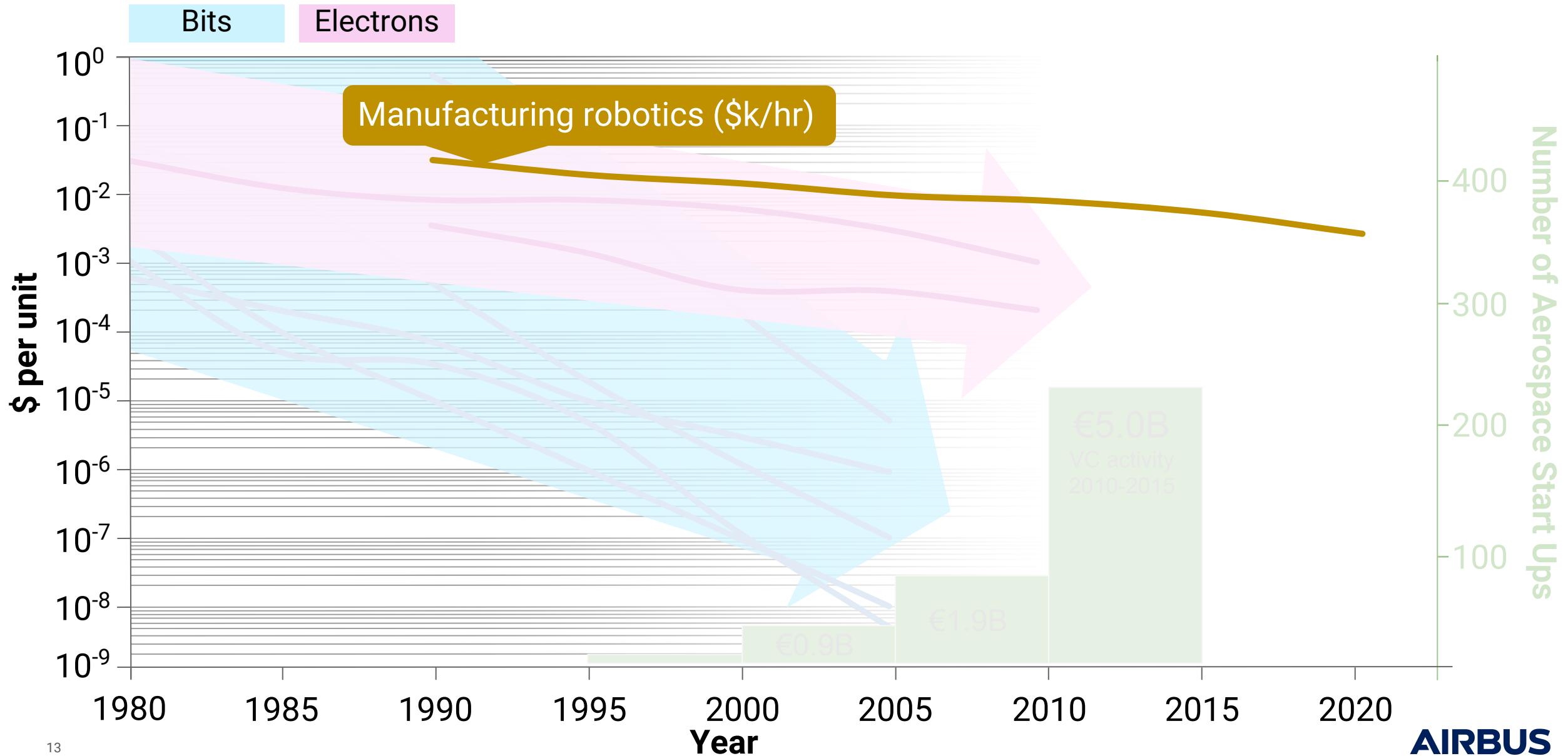

Atoms: Additive manufacturing

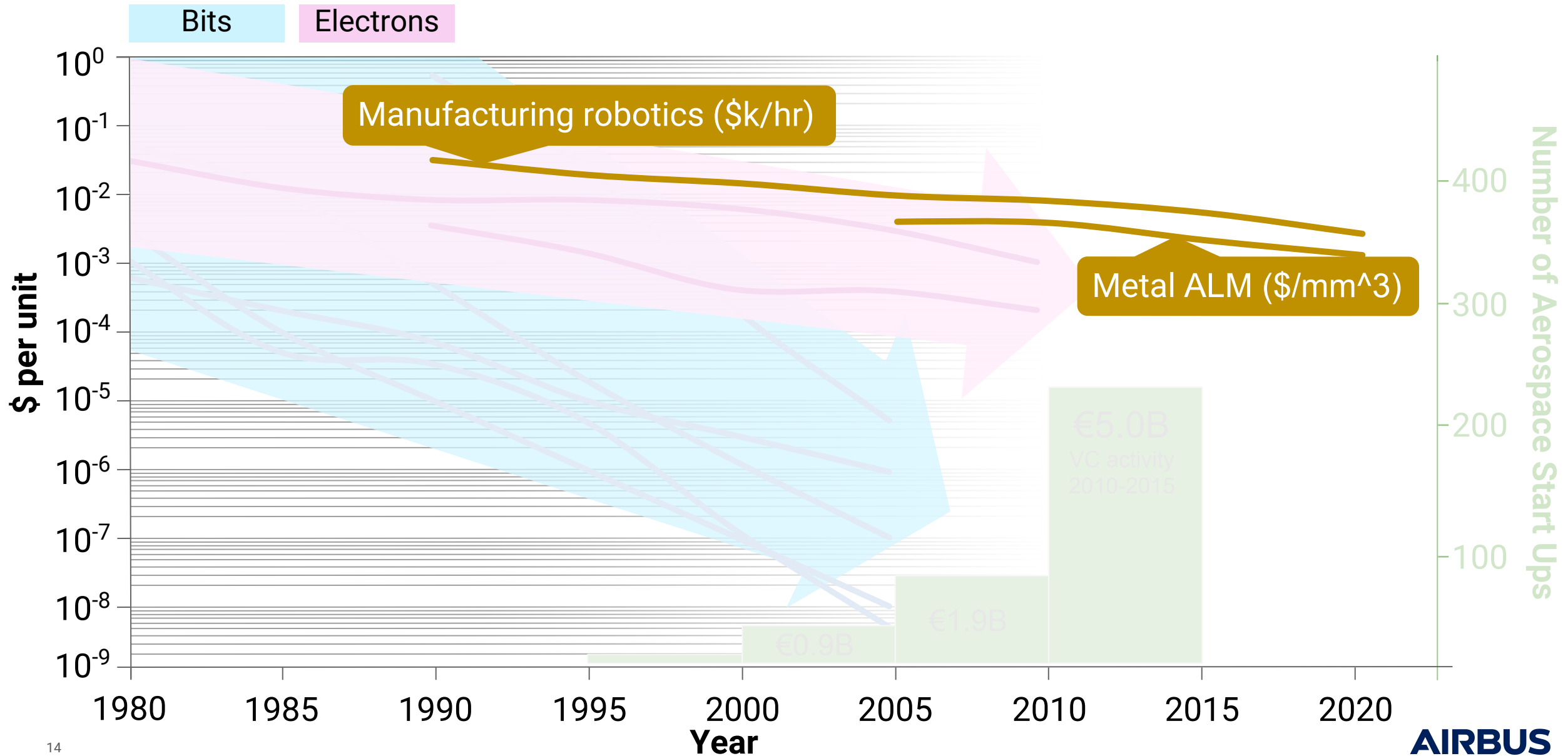

Atoms: Synthetic biology

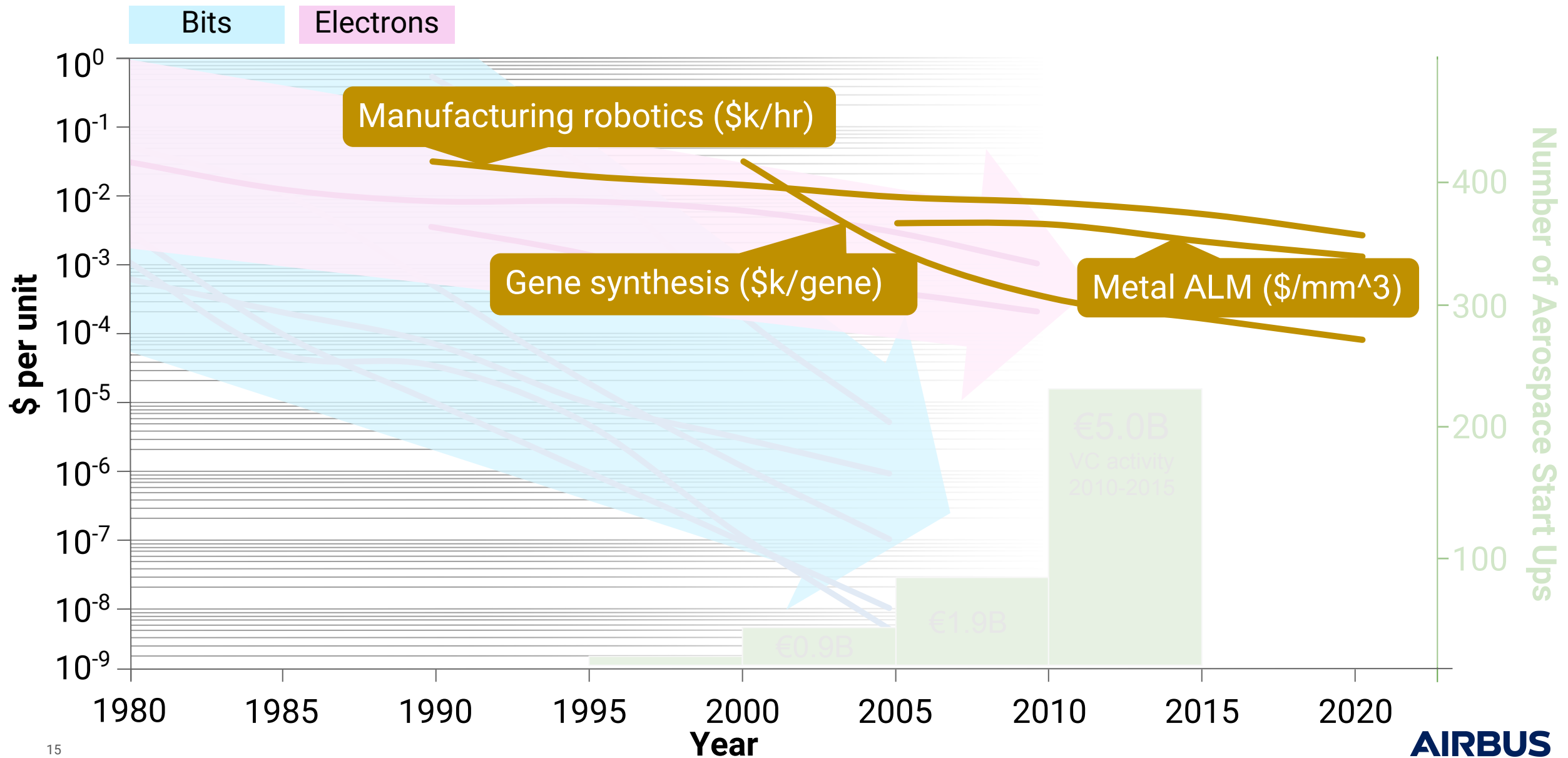

Direct manipulation of atoms

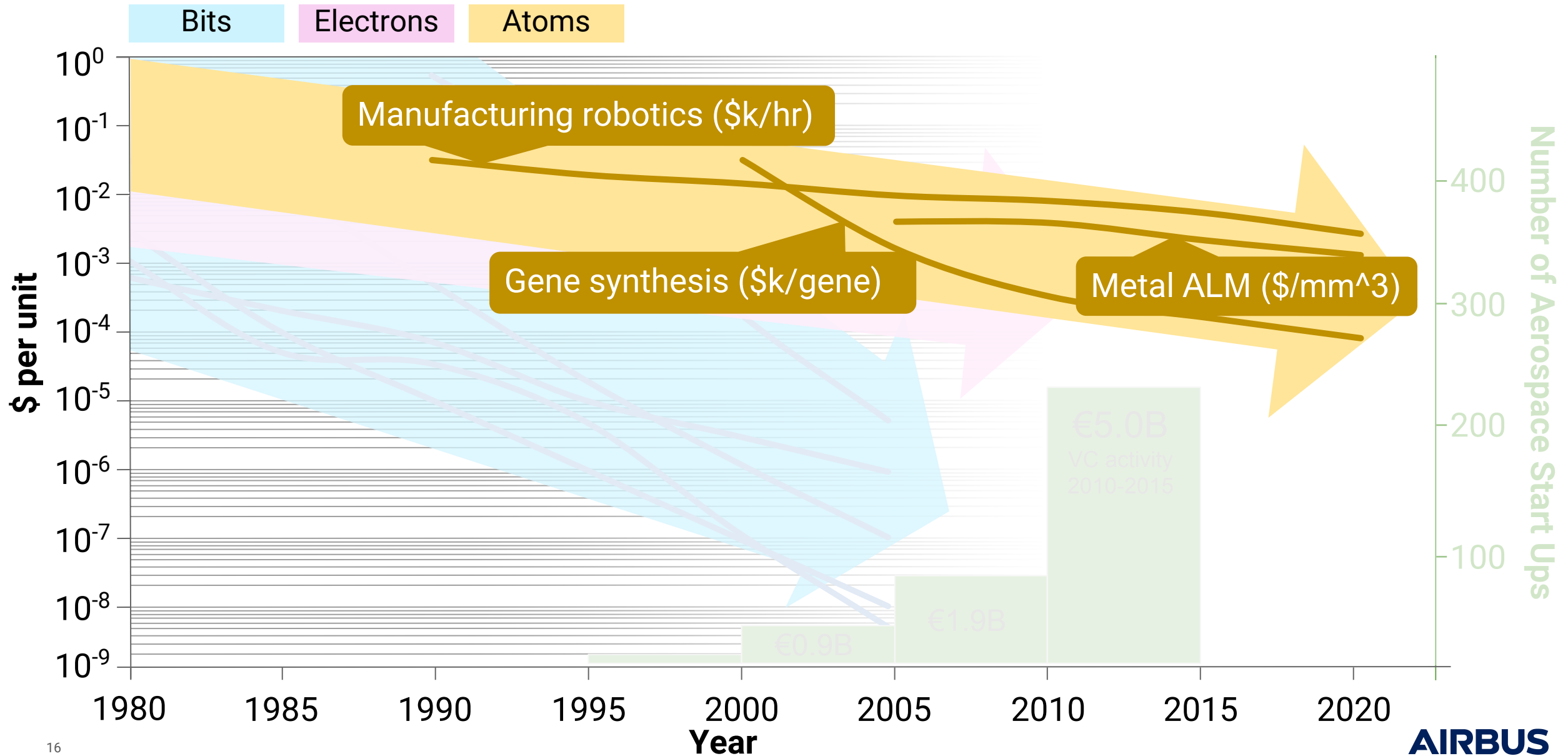

Compared to aviation

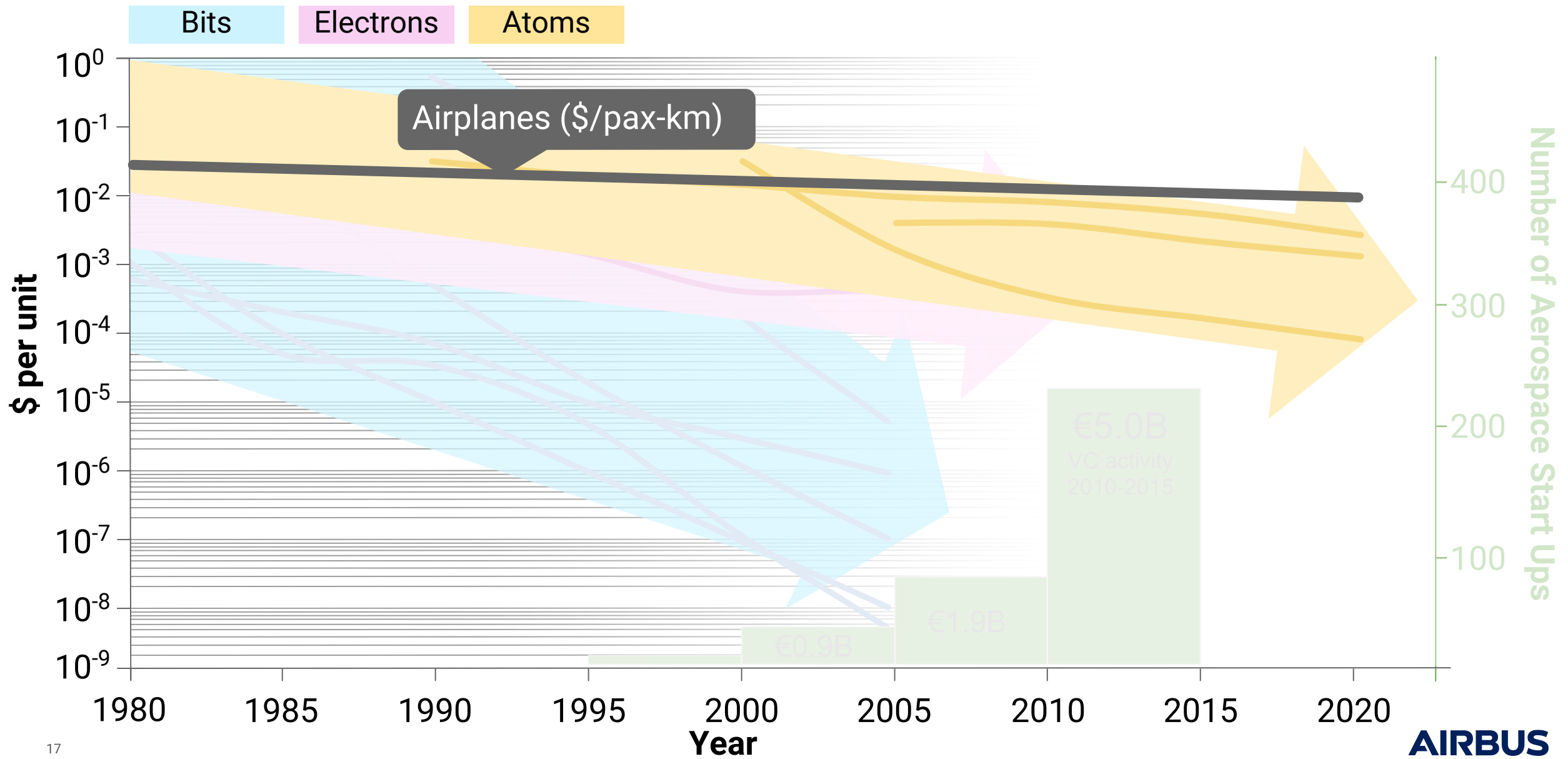

Are we moving fast enough?

Airbus research, technology, and innovation ecosystem



Airbus research, technology, and innovation ecosystem



Technology roadmapping methodology

Architecture

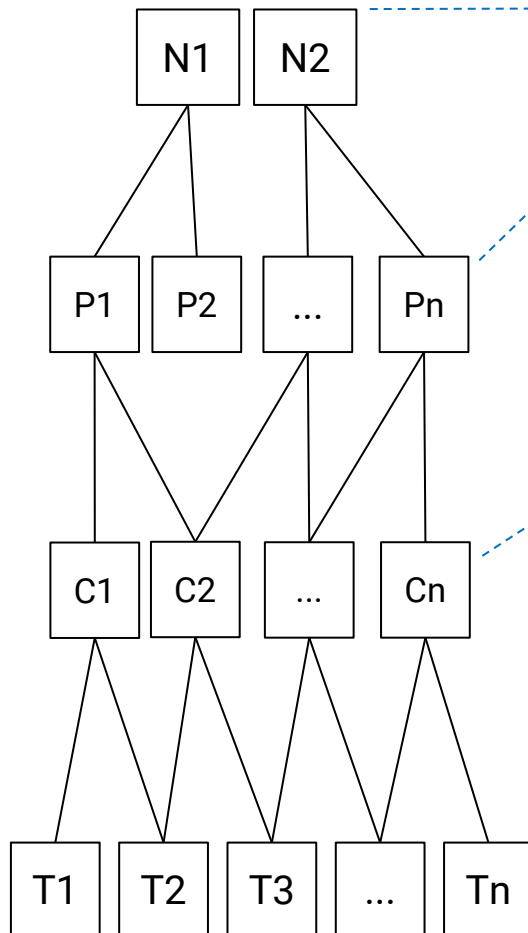

Actual roadmap graph

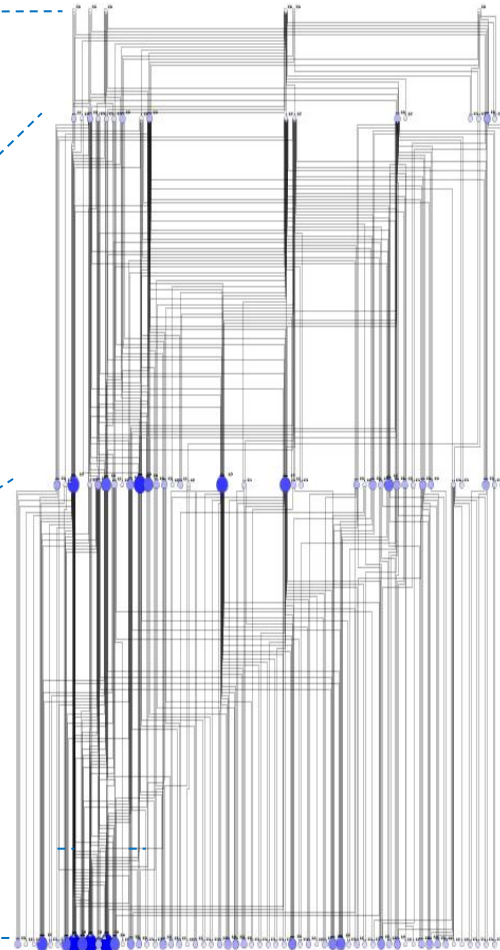

Steps

- 1. Where are we today?**
Technology Roadmapping and Assessment
- 2. Where could we go?**
System Architecture Exploration (CDF)
- 3. Where should we go?**
Scenario Analysis and Technology Valuation
- 4. Where we are going!**
R&T Portfolio Optimization & Demonstrator Plans

Outputs

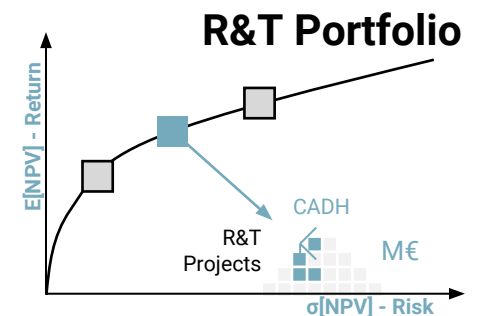
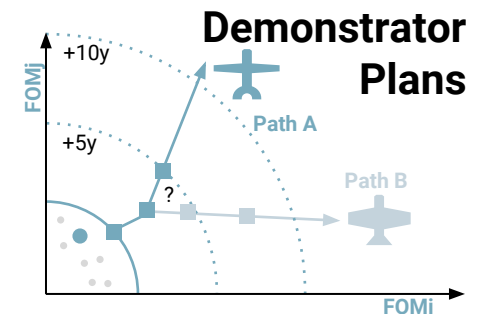
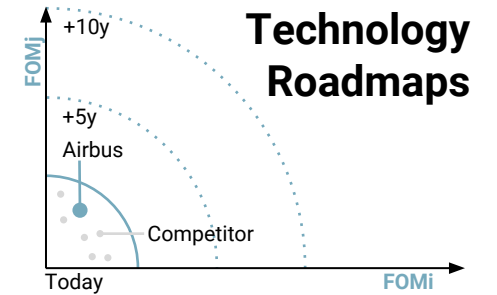

Airbus research, technology, and innovation ecosystem

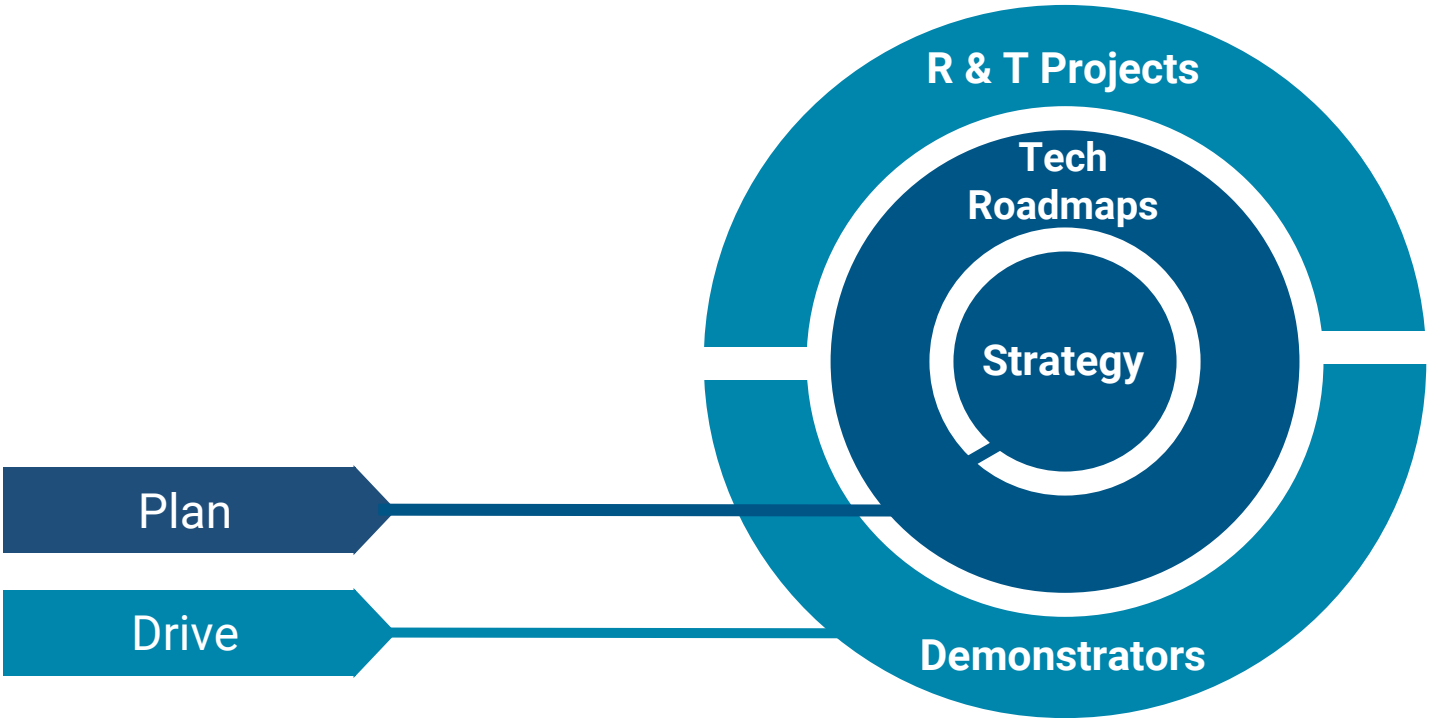

Airbus research, technology, and innovation ecosystem

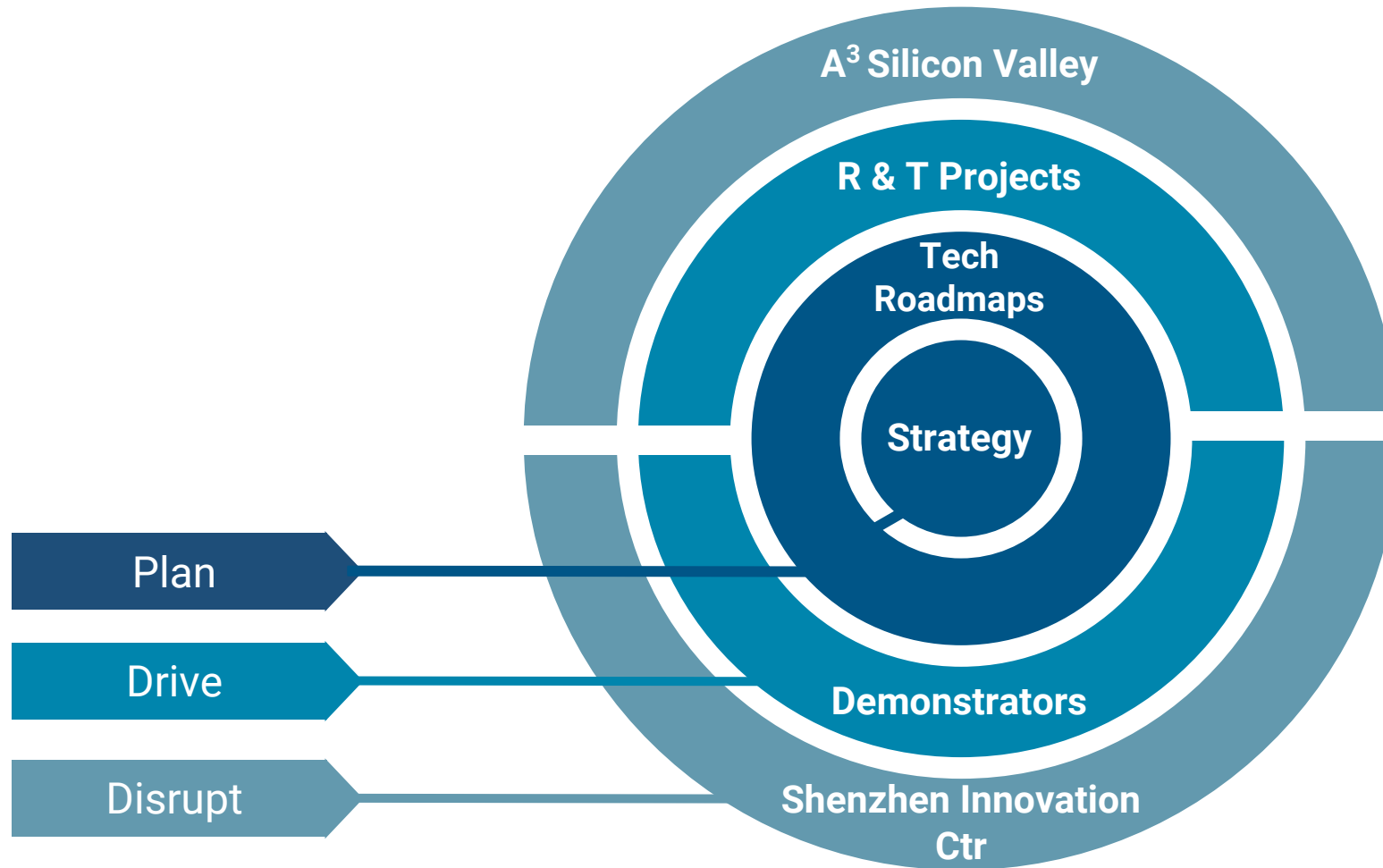

Airbus research, technology, and innovation ecosystem

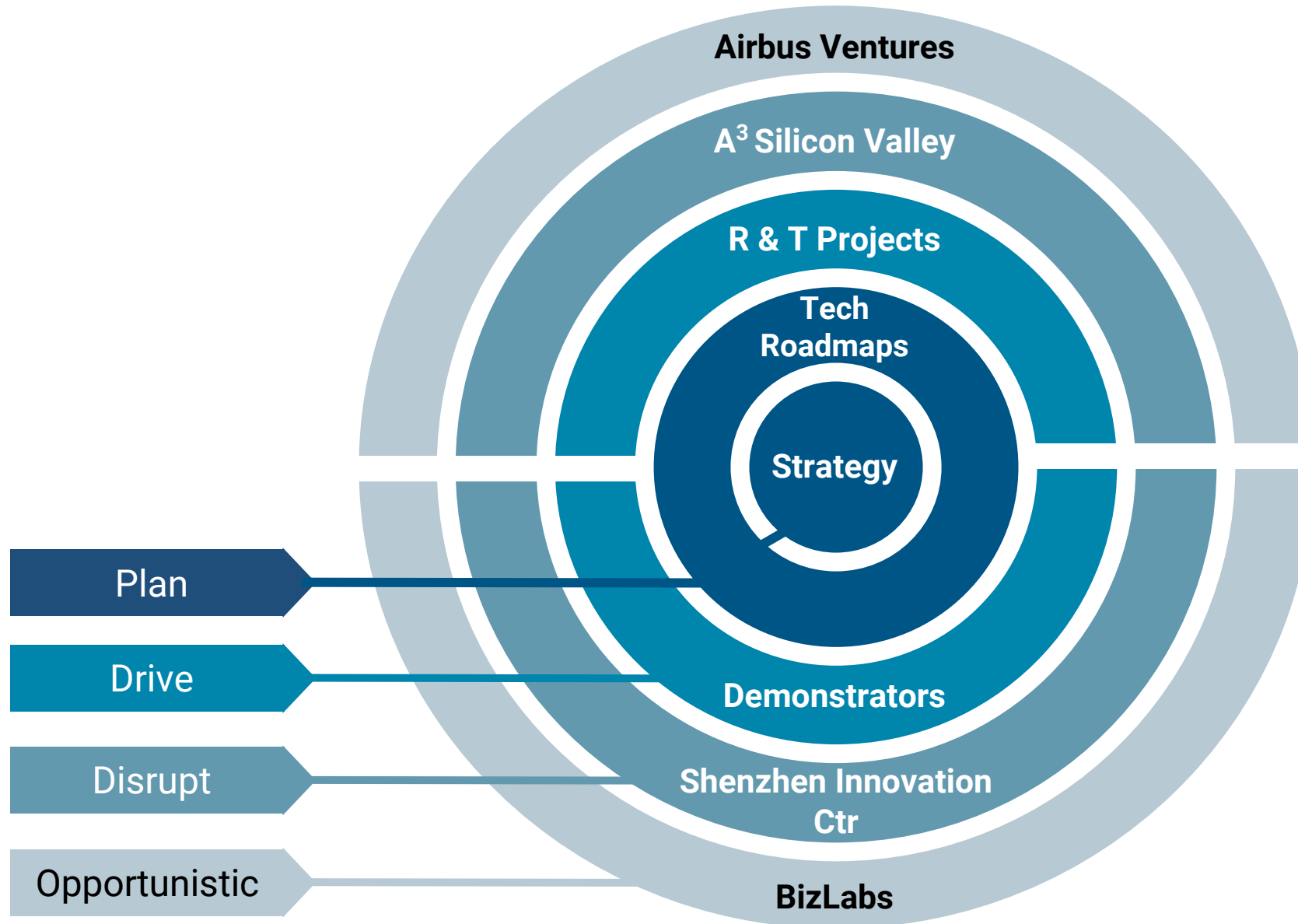

Airbus research, technology, and innovation ecosystem

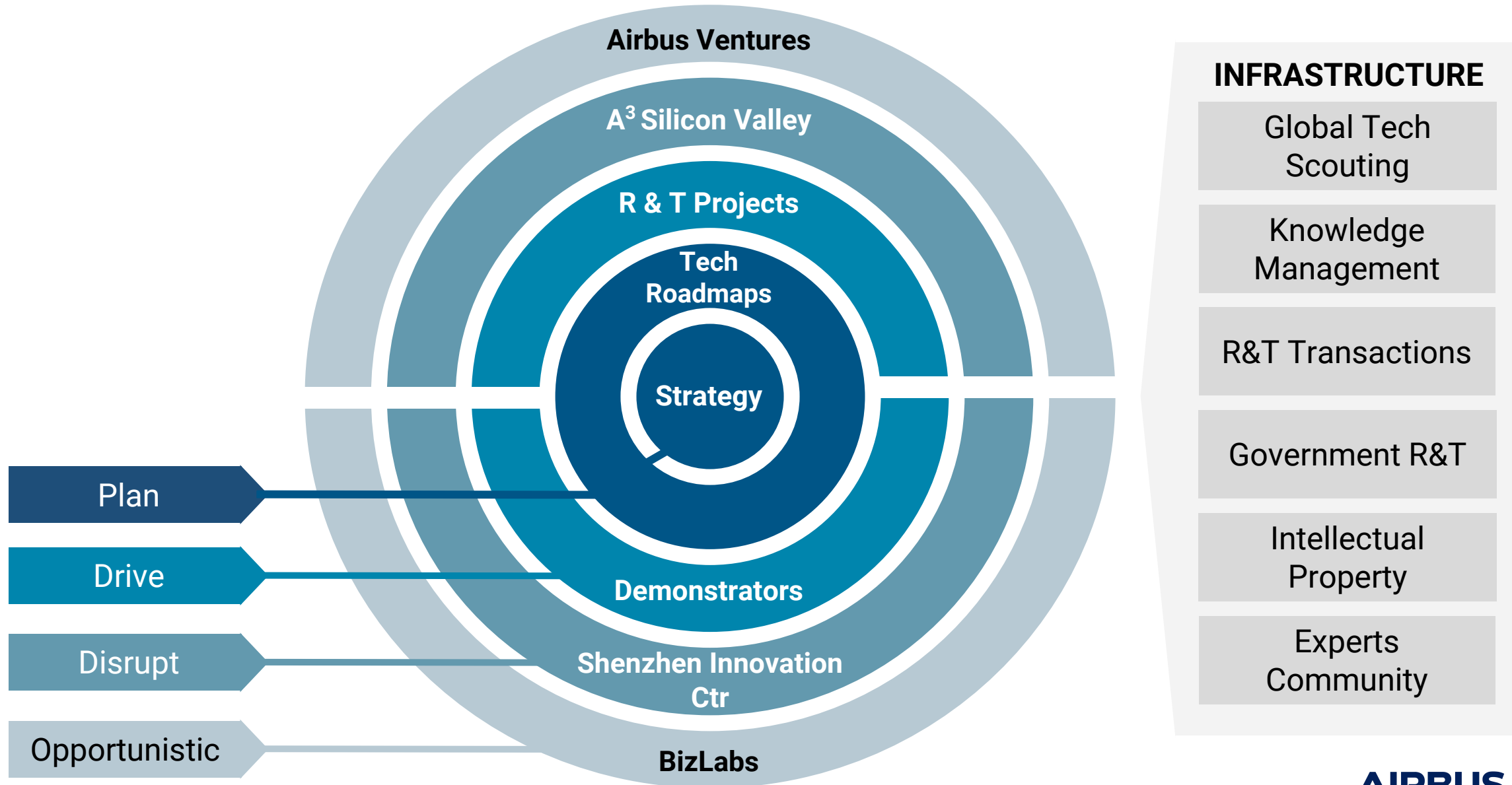

Airbus research, technology, and innovation ecosystem



■ Core R&T Sites

Airbus research, technology, and innovation ecosystem



Airbus research, technology, and innovation ecosystem

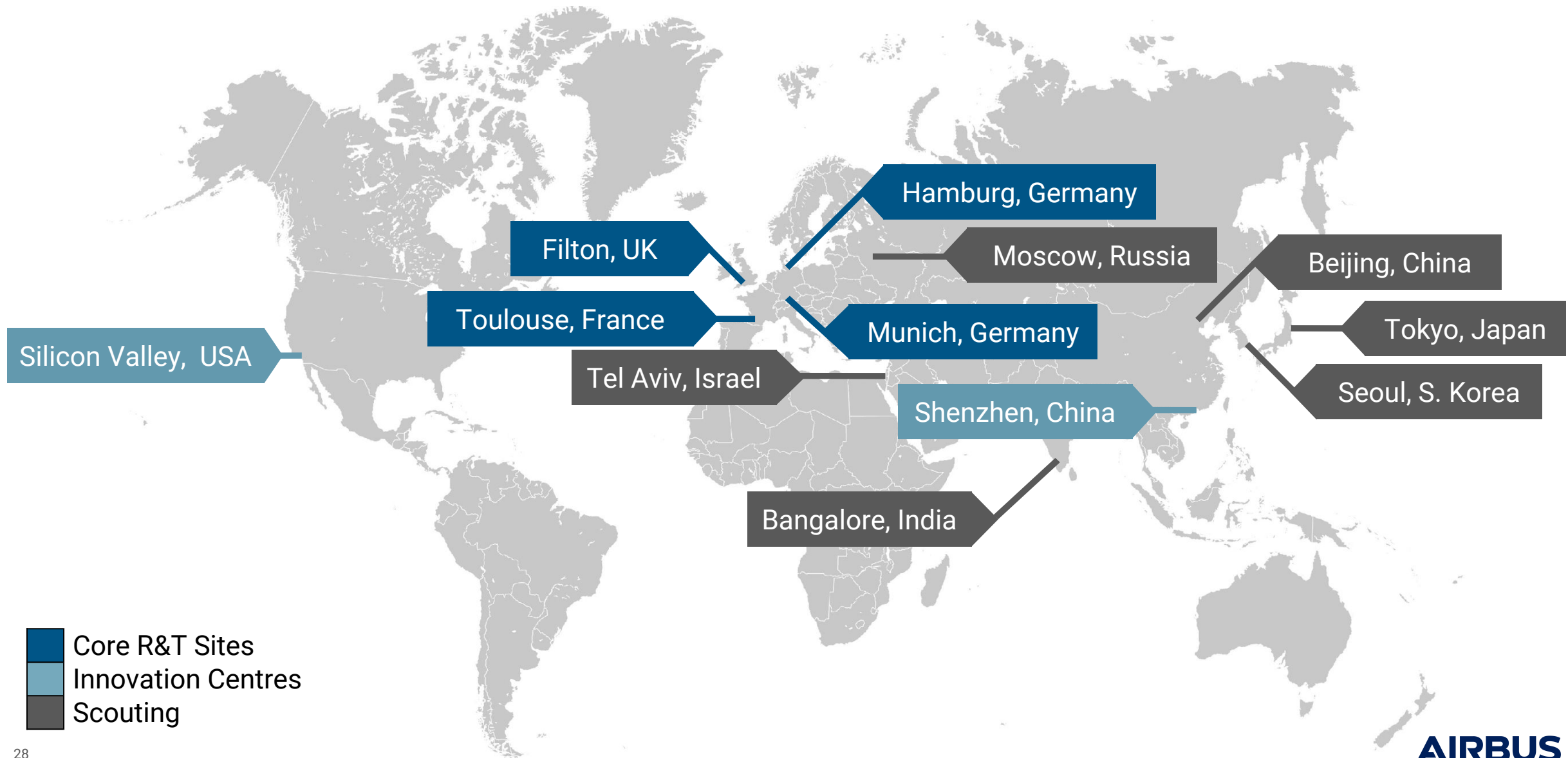

Some examples...

Electric flight

Electric flight: Cri-Cri



First flight

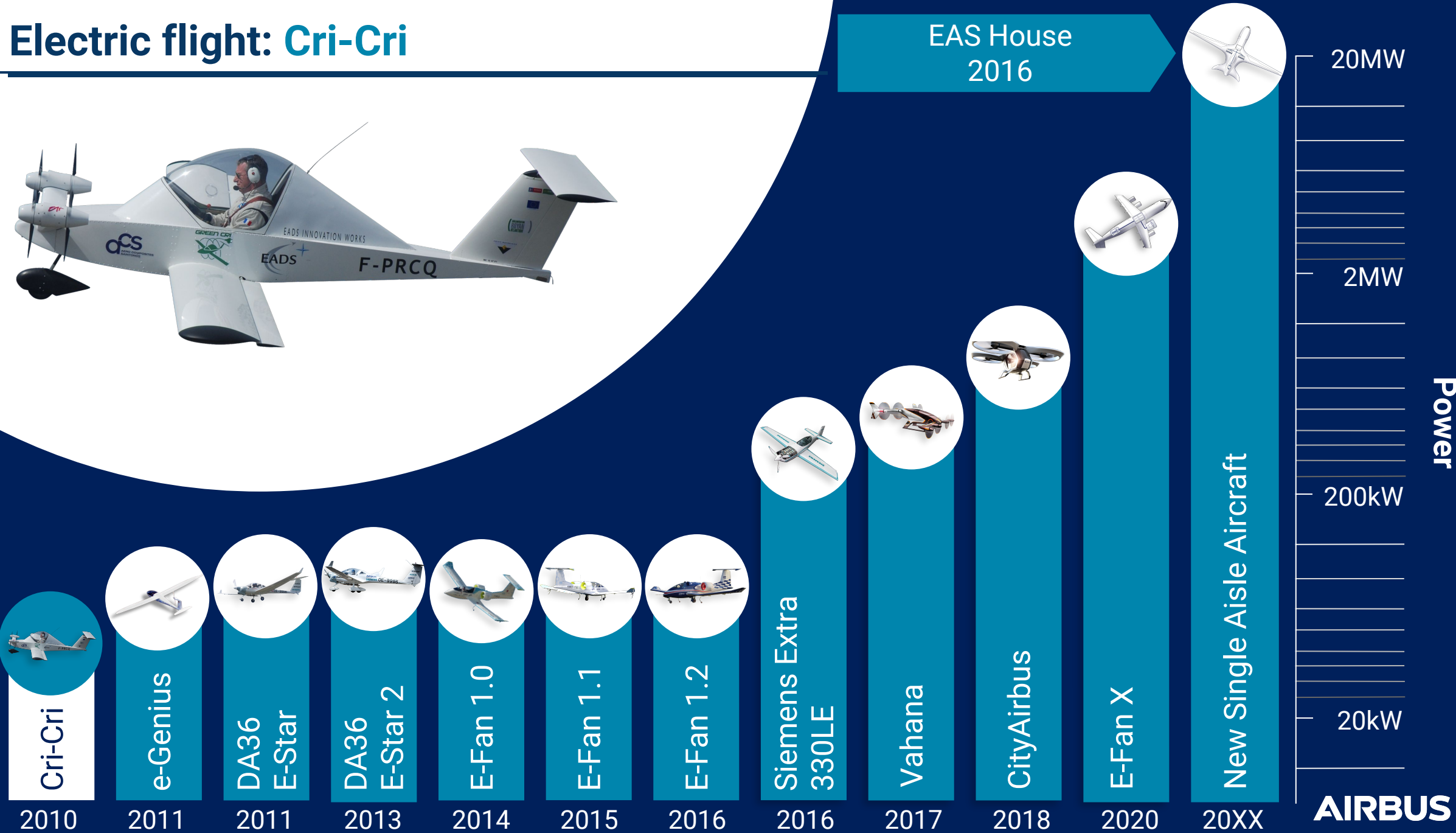

EAS House 2016



20MW

2MW

200kW

20kW

Power

AIRBUS

Electric flight: e-Genius



First flight

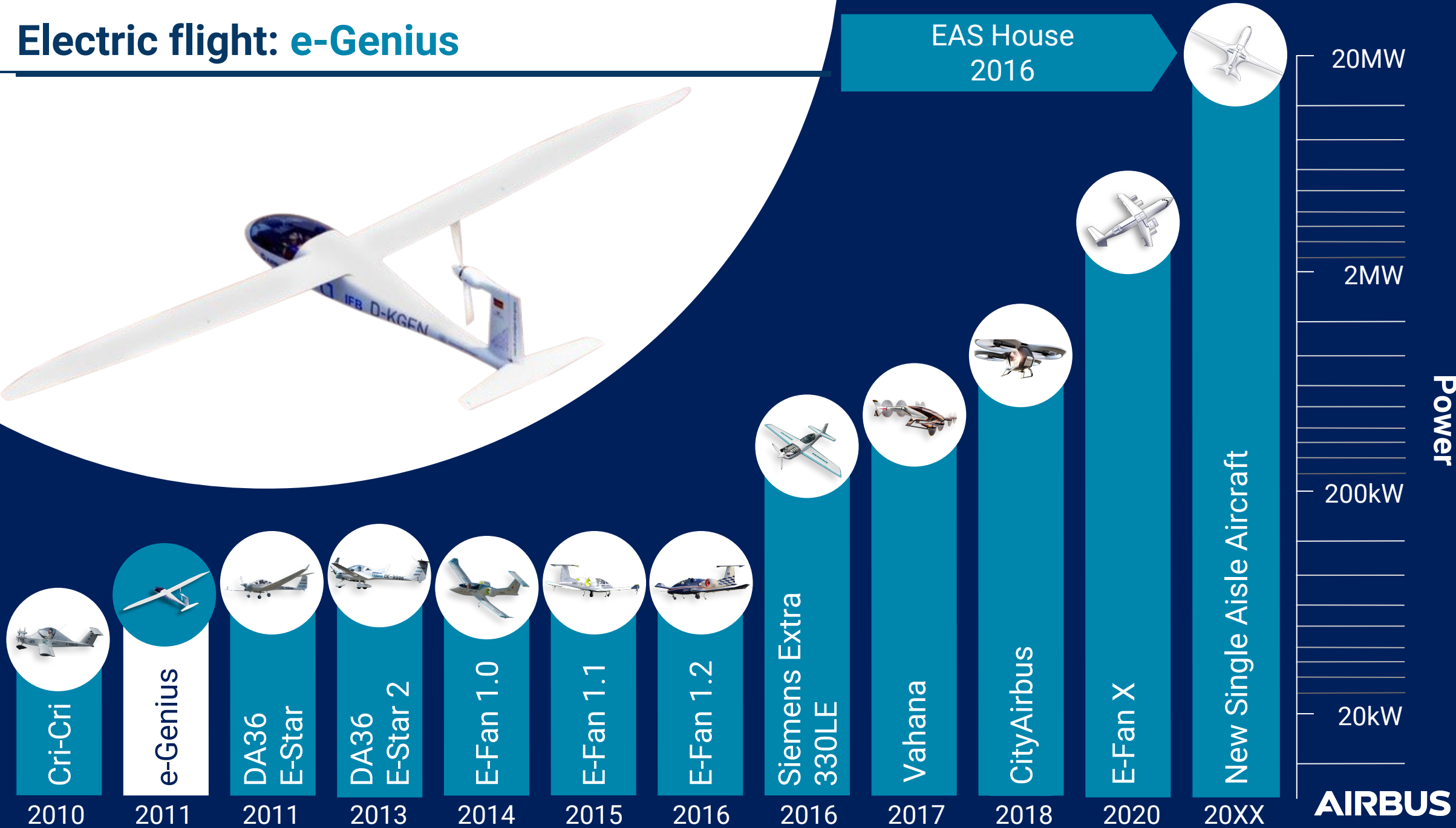

EAS House
2016



20MW

2MW

200kW

20kW

Power

New Single Aisle Aircraft

AIRBUS

Hybrid-electric flight: E-Star



First flight

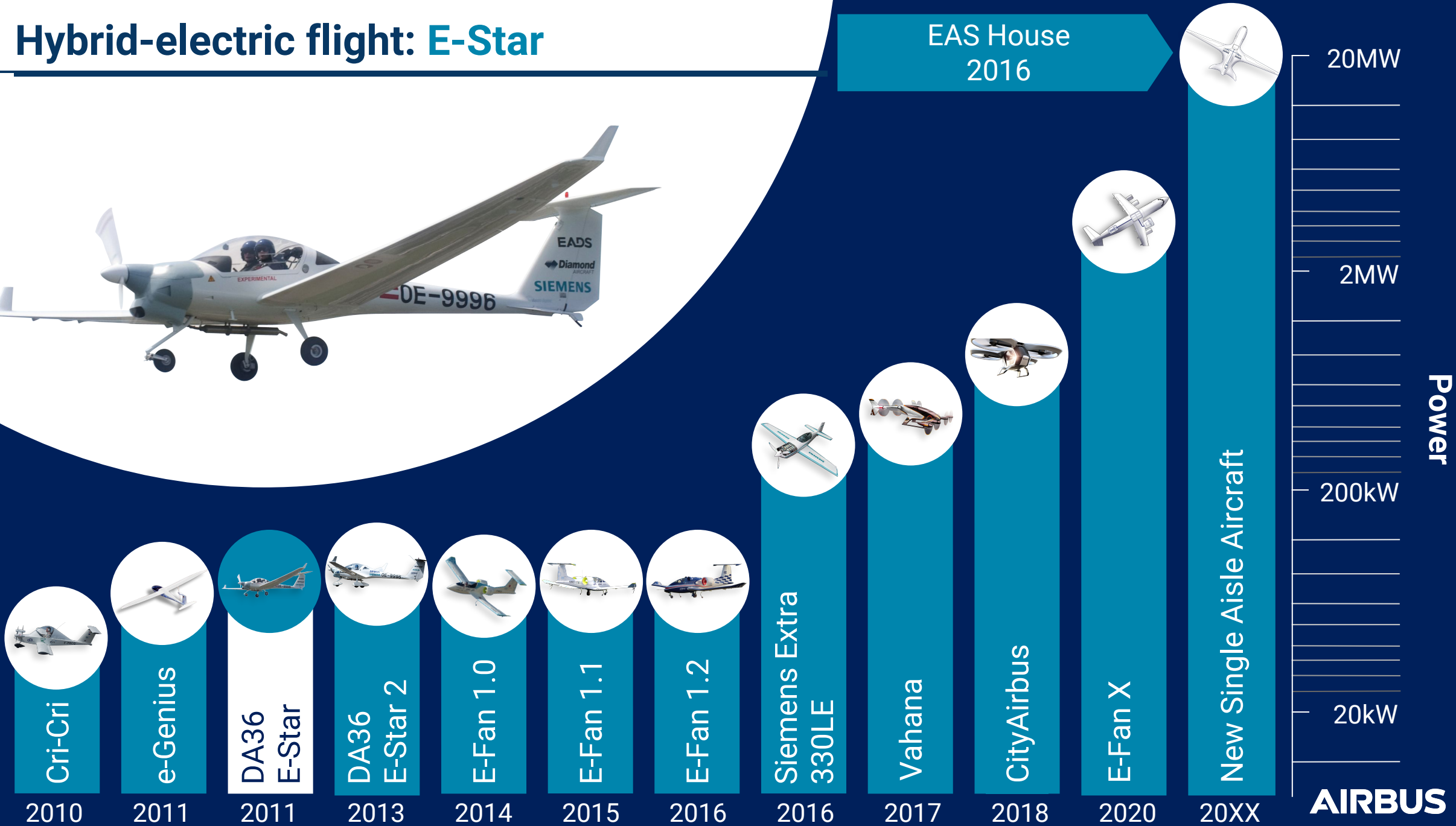

AIRBUS

Hybrid-electric flight: E-Star 2



EAS House
2016



20MW

2MW

200kW

20kW

Power

First flight

Cri-Cri
2010

e-Genius
2011

DA36
E-Star
2011

DA36
E-Star 2
2013

E-Fan 1.0
2014

E-Fan 1.1
2015

E-Fan 1.2
2016

Siemens Extra
330LE
2016

Vahana
2017

CityAirbus
2018

E-Fan X
2020

New Single Aisle Aircraft
20XX

AIRBUS

Electric flight: E-Fan 1.0



First flight

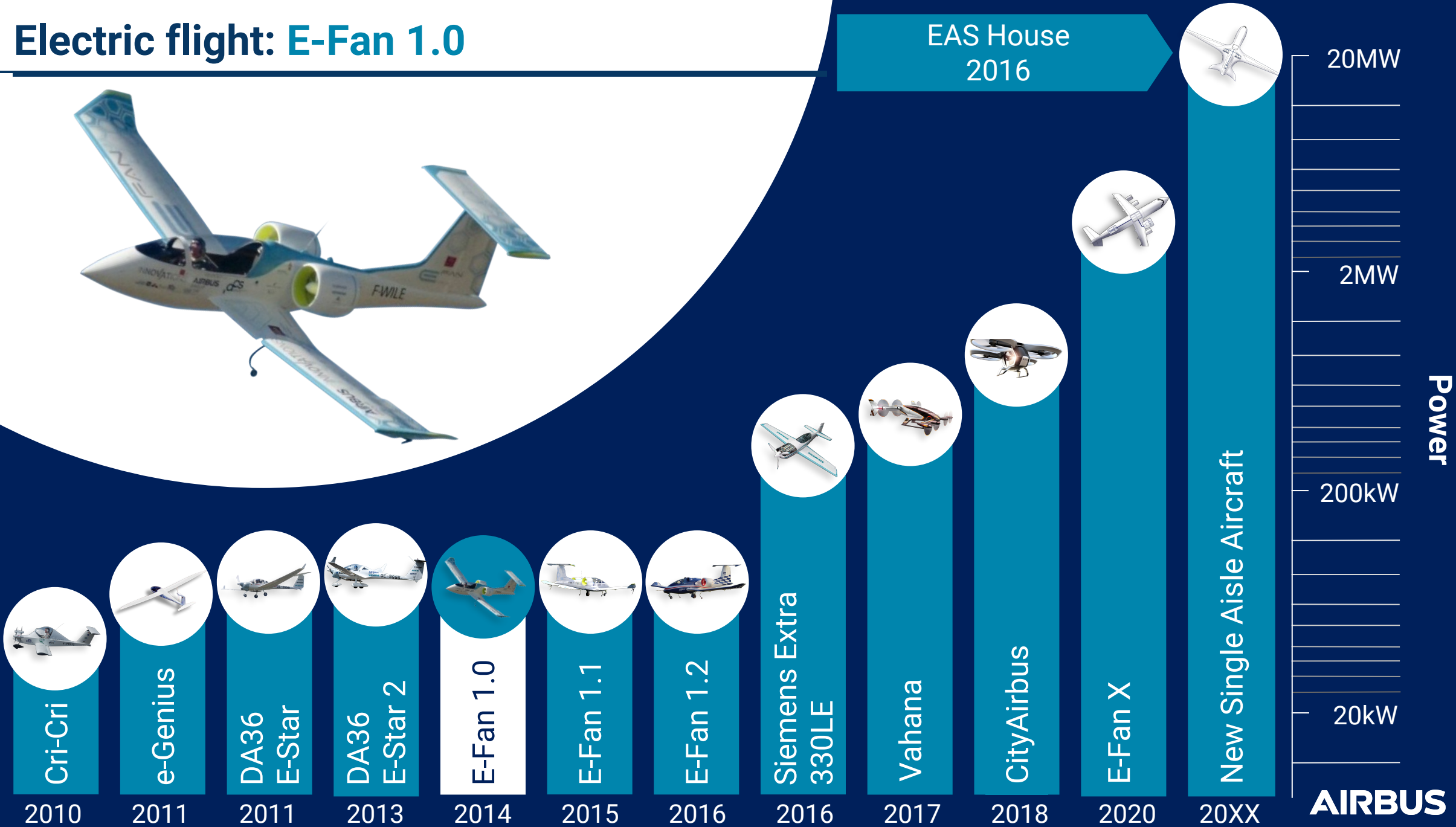

EAS House 2016



Power

AIRBUS

Electric flight: E-Fan 1.1



First flight

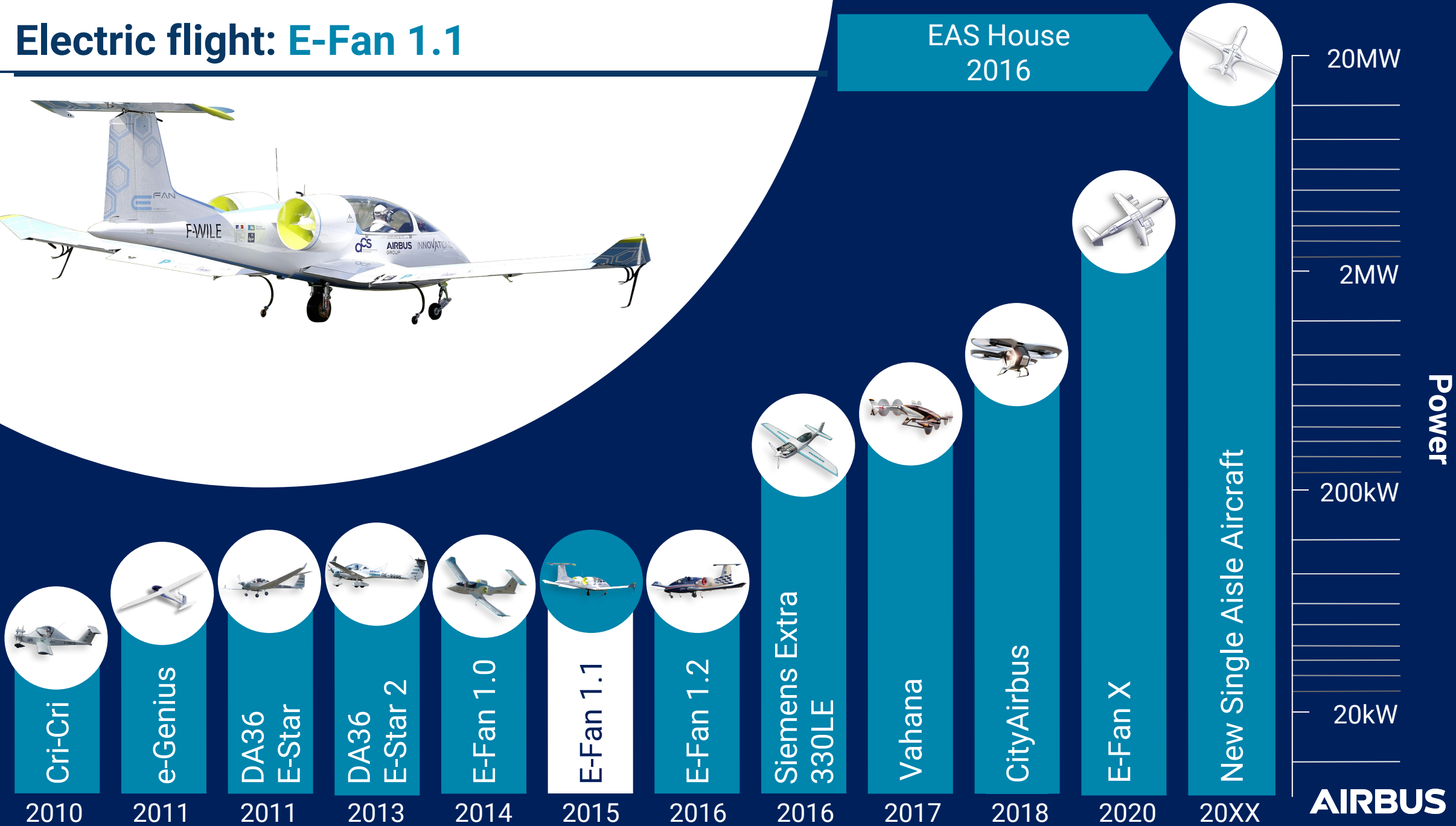

EAS House 2016



20MW

2MW

200kW

20kW

Power

AIRBUS

Hybrid-electric flight: E-Fan 1.2



First flight

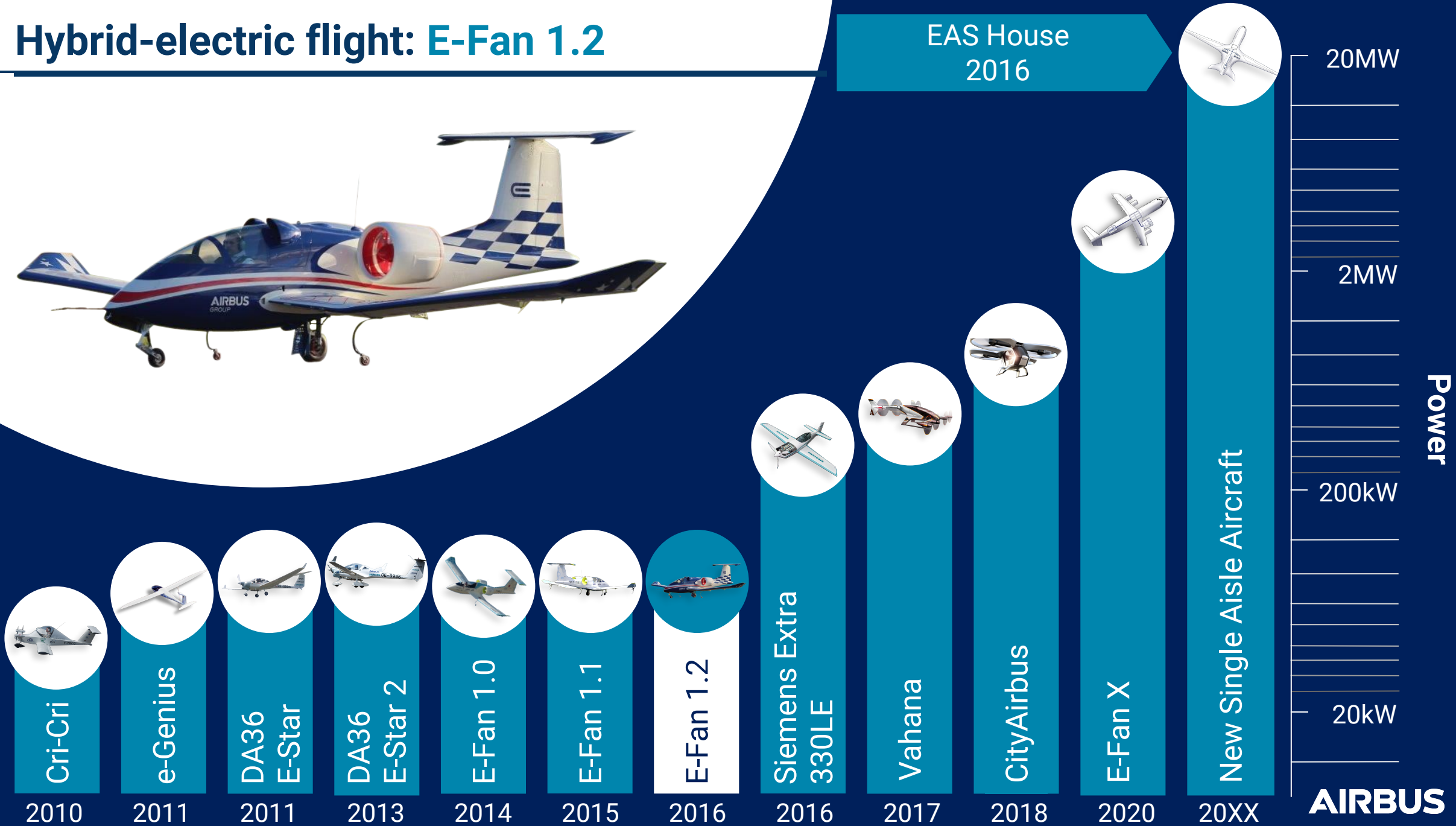

EAS House 2016



Power

AIRBUS

Electric flight: Siemens Extra 330LE



EAS House
2016



Power

First flight

2010

2011

2011

2013

2014

2015

2016

2016

2017

2018

2020

20XX

AIRBUS

Electric testbed: E-Aircraft Systems House

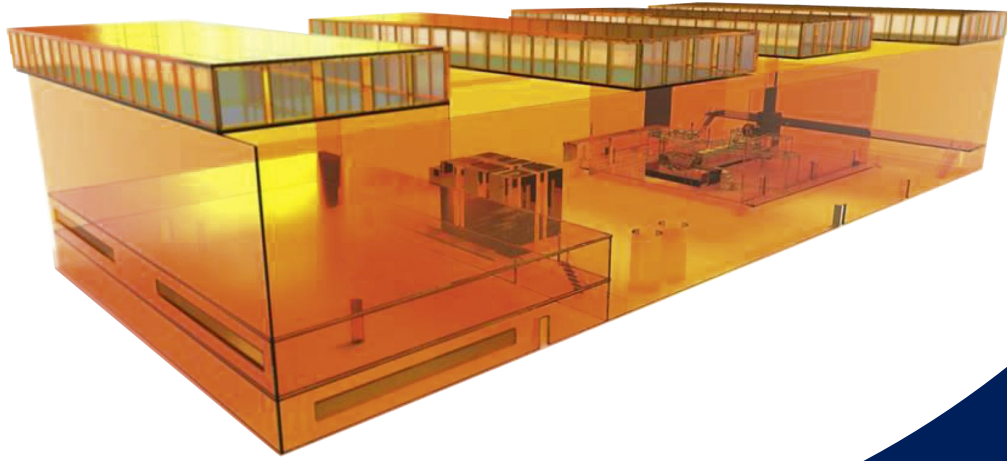

EAS House
2016

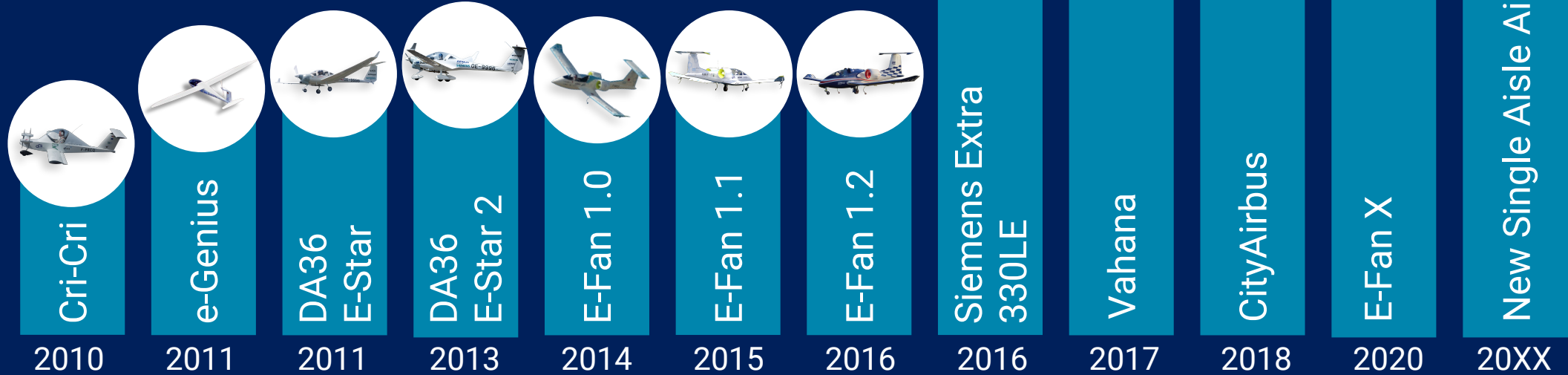

Power

First flight

AIRBUS

Electric flight: Vahana



First flight

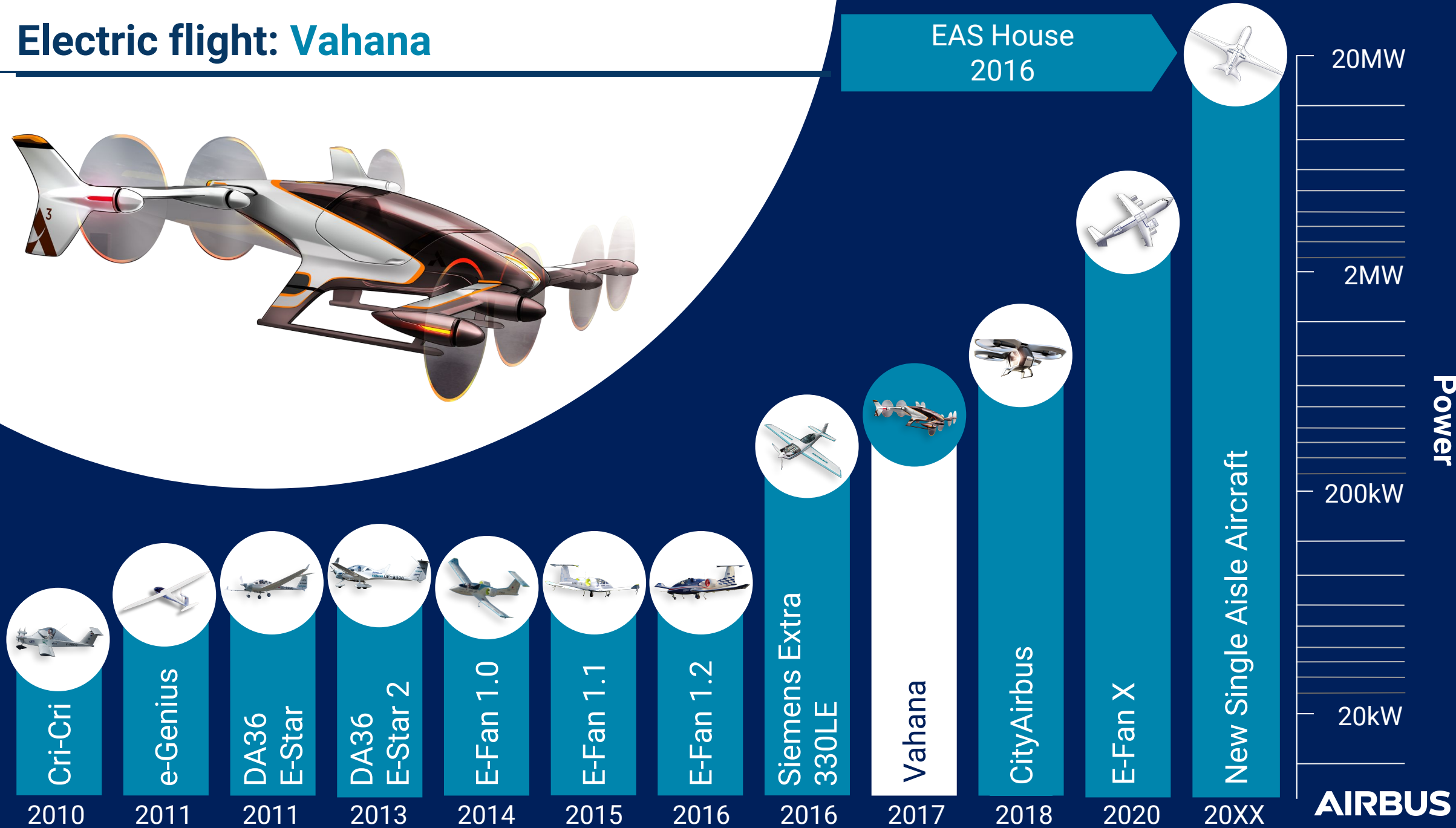

EAS House 2016



20MW

2MW

200kW

20kW

Power

AIRBUS

Electric flight: CityAirbus



First flight

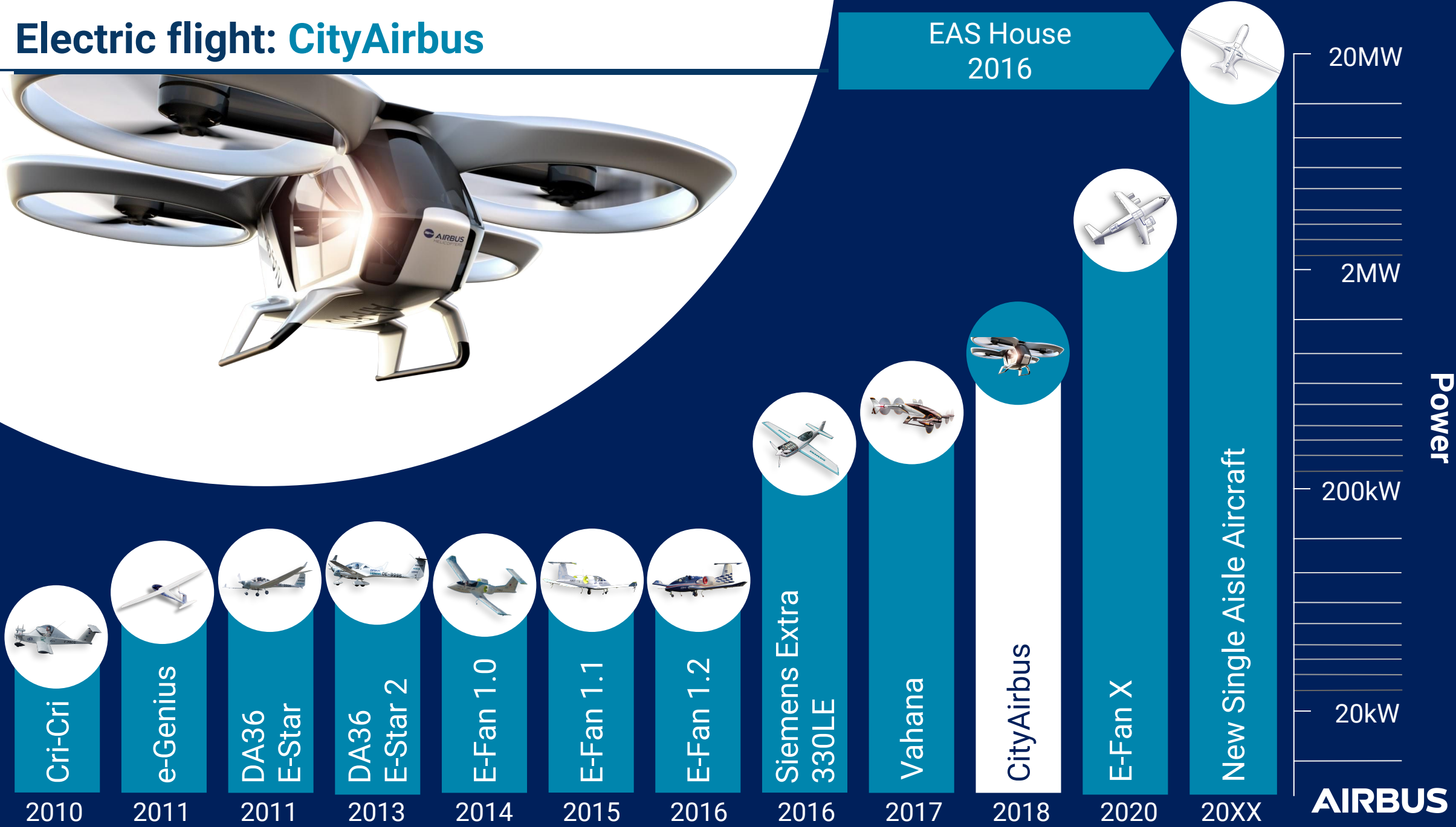

AIRBUS

Hybrid-electric flight: E-Fan X

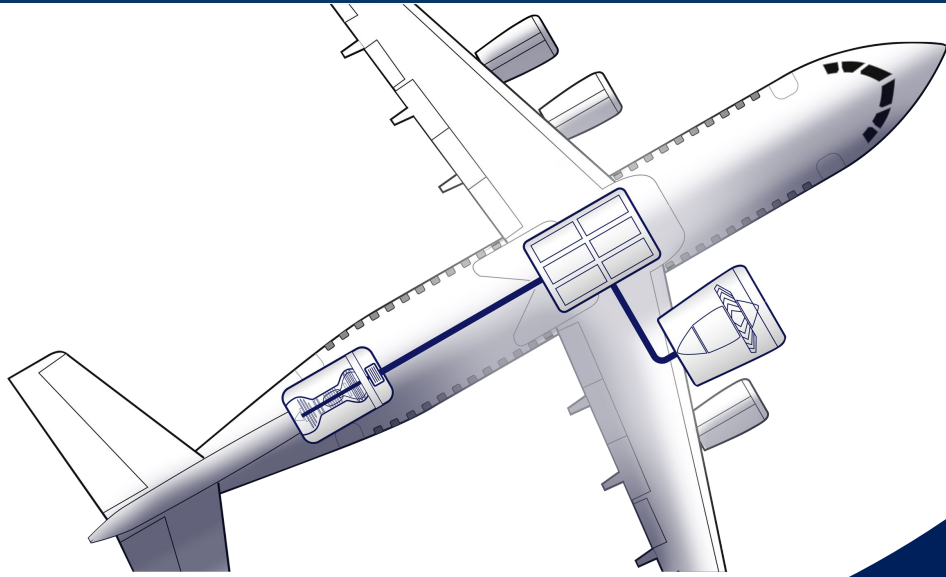

EAS House
2016



20MW

2MW

Power

200kW

20kW

New Single Aisle Aircraft

AIRBUS

First flight



Cri-Cri

2010

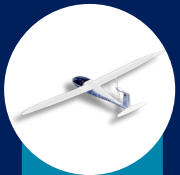

e-Genius

2011



DA36
E-Star

2011



DA36
E-Star 2

2013



E-Fan 1.0

2014



E-Fan 1.1

2015



E-Fan 1.2

2016



Siemens Extra
330LE

2016



Vahana

2017



CityAirbus

2018



E-Fan X

2020



20XX

Hybrid-electric flight: New Single Aisle

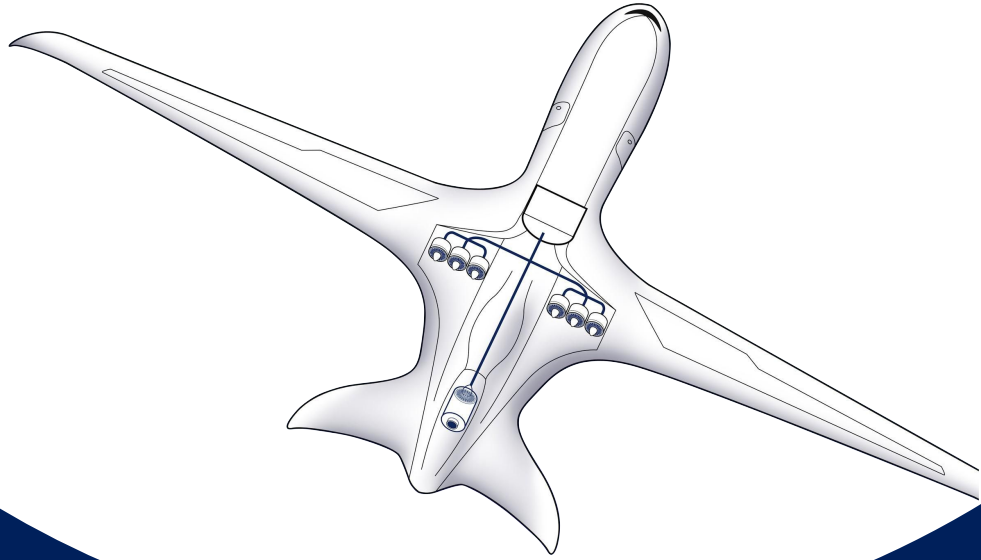

EAS House
2016



First flight

Cri-Cri

e-Genius

DA36
E-Star

DA36
E-Star 2

E-Fan 1.0

E-Fan 1.1

E-Fan 1.2

Siemens Extra
330LE

Vahana

CityAirbus

E-Fan X

New Single Aisle Aircraft



AIRBUS

Urban air mobility













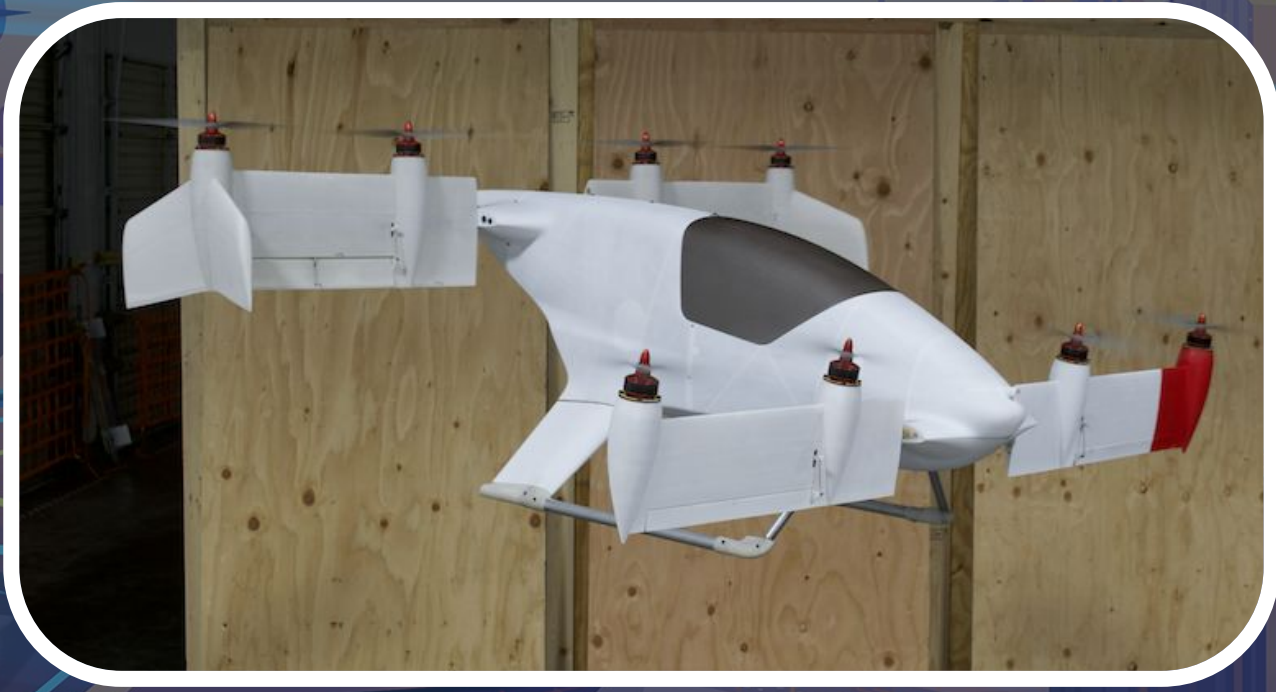









Vcom BETA

Av. Brg. Faria Lima, 3989 - Itaim Bibi, São Paul

Rodovia Hélio Smidt, Guarulhos - SP, Brazil

SCHEDULE A FLIGHT

Please enter the addresses where you will begin and end your journey. We will find the nearest helipad to your locations.







@PaulEremenko